



# Racor para mangueras m-top

## Tipo CVG EMV (racor para mangueras y para cables con rosca de metal)



De -40 a +110 °C  
Brevemente +140 °C



Poliamida/latón niquelado



V0



IP 68 hasta 6 bar (IP 69K)

Racor recto combinado para mangueras y para cables con rosca de metal.

- Insertar la manguera → Apretar la parte superior → Listo
- Montaje seguro puesto que el racor está motado por completo. No se necesitan más piezas
- A prueba de vibraciones gracias a la tuerca de racor encastrable
- Sujeción de toda la circunferencia de la manguera, con lo cual se obtiene la máxima resistencia a la rotura
- Elevada estanqueidad de grado IP 68 hasta 6 bar (IP69K) sin piezas adicionales
- Fácil control del montaje correcto de la manguera



CVG EMV

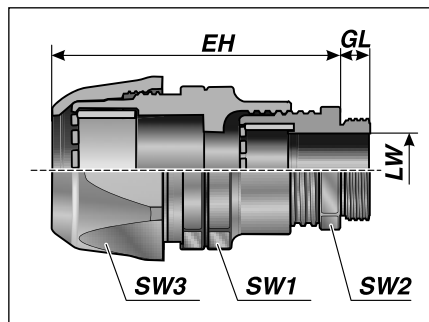

Tipo	Nº de pedido	Color	Rosca de empalme	Válido para murrflex	EH mm	GL mm	LW mm	SW 1/2/3 mm	UE un.
<b>Rosca métrica de metal/ejecución CEM</b>									
CVG M12 EMV	83551050	negro	M12x1,5	M12 / P9	39,0	5,0	3,0 - 6,5	20/14/20	50
CVG M16 EMV	83551052	negro	M16x1,5	M16 / P11	45,0	6,0	5,0 - 10,0	25/20/25	50
CVG M20 EMV	83551056	negro	M20x1,5	M20 / P16	55,0	6,0	10,0 - 14,0	33/24/33	50
CVG M25 EMV	83551058	negro	M25x1,5	M25 / P21	57,0	7,0	13,0 - 18,0	40/30/41	50
CVG M32 EMV	83551060	negro	M32x1,5	M32 / P29	69,0	8,0	18,0 - 25,0	50/40/50	25
CVG M40 EMV	83551062	negro	M40x1,5	M40 / P36	84,0	8,0	22,0 - 32,0	60/50/60	25
CVG M63 EMV	83551064	negro	M63x1,5	M50 / P48	94,0	10,0	37,0 - 44,0	75/68/75	10
<b>Rosca métrica de metal/ejecución CEM con rosca alargada</b>									
CVG/L M12 EMV	83551650	negro	M12x1,5	M12 / P9	39,0	10,0	3,0 - 6,5	20/14/20	50
CVG/L M16 EMV	83551652	negro	M16x1,5	M16 / P11	45,0	10,0	5,0 - 10,0	25/20/25	50
CVG/L M20 EMV	83551656	negro	M20x1,5	M20 / P16	55,0	10,0	10,0 - 14,0	33/24/33	50
CVG/L M25 EMV	83551658	negro	M25x1,5	M25 / P21	57,0	12,0	13,0 - 18,0	40/30/41	50
CVG/L M32 EMV	83551660	negro	M32x1,5	M32 / P29	69,0	12,0	18,0 - 25,0	50/40/50	25
CVG/L M40 EMV	83551662	negro	M40x1,5	M40 / P36	84,0	15,0	22,0 - 32,0	60/50/60	25

Representante oficial de:



[Argentina – Colombia – Ecuador – Bolivia – Paraguay.]



Calle 49 N° 5764 - Villa Ballester (B1653AOX) - Prov. de Buenos Aires - ARGENTINA  
Tel: (+54 11) 4768-4242 / Fax: (+54 11) 4849-1212  
Mail: [ventas@nakase.com.ar](mailto:ventas@nakase.com.ar) / Web: [www.nakase.com.ar](http://www.nakase.com.ar)

