



# HEIDENHAIN



## Touch Probes for Machine Tools

October 2010

Representante oficial de:



**HEIDENHAIN**

[Argentina – Bolivia – Chile – Colombia - Costa Rica – Ecuador - El Salvador –  
Guatemala – Honduras – Nicaragua – Panamá – Paraguay – Perú -  
República Dominicana – Uruguay – Venezuela.]



Calle 49 N° 5764 - Villa Ballester (B1653AOX) - Prov. de Buenos Aires - ARGENTINA  
Tel: (+54 11) 4768-4242 / Fax: (+54 11) 4849-1212  
Mail: [ventas@nakase.com.ar](mailto:ventas@nakase.com.ar) / Web: [www.nakase.com.ar](http://www.nakase.com.ar)



# Touch Probe Systems for Machine Tools

Touch probes from HEIDENHAIN were conceived for use on machine tools—in particular milling machines and machining centers. Touch probes help to reduce setup times, increase machine usage time and improve the dimensional accuracy of the finished workpieces. Setup, measuring and monitoring functions can be performed manually or—in conjunction with most CNC controls—under program control.

## Workpiece measurement

HEIDENHAIN offers **TS triggering touch probes** for workpiece measurement right on the machine. The probe is inserted in the tool holder either manually or by the tool changer. They enable you to use the probing functions offered by your NC control to automatically or manually perform the following functions:

- Workpiece alignment
- Workpiece presetting
- Workpiece measurement
- Digitizing or inspecting 3-D surfaces

## Tool measurement

Successful series production hinges on the prevention of scrap or rework and the attainment of consistently good workmanship. The tool is a decisive factor here. Wear or tool breakage that go undetected for extended periods, especially during unattended operation, result in defective parts and unnecessarily increase costs. Therefore, exact measurement of tool dimensions and periodic control of wear are absolutely essential. For tool measurement on the machine, HEIDENHAIN offers the TT three-dimensional touch probe and the TL laser systems.

With the **TT triggering touch probes**, the contact plate is deflected from its rest position, sending a trigger signal to the NC control, during probing of the stationary or rotating tool.

The **TL laser systems** operate without any contact. A laser beam probes the length, diameter or contour of the tool. Special measuring cycles in the NC control evaluate the information.

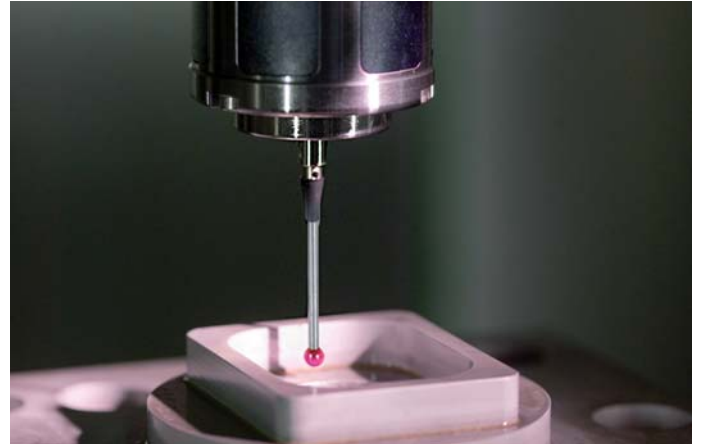

# Contents

<b>Application Examples</b>		
<b>Workpiece Alignment</b>		<b>4</b>
<b>Workpiece Presetting</b>		<b>5</b>
<b>Workpiece Measurement</b>		<b>6</b>
<b>Practical Examples: Reducing Nonproductive Time</b>		<b>7</b>
<b>Tool Measurement</b> with the TT Touch Probe		<b>8</b>
<b>Tool Measurement</b> with the TL Laser System		<b>9</b>
<b>Workpiece Measurement</b>		
<b>TS Touch Probes</b>	Selection Guide	<b>10</b>
	Principle of Function	<b>12</b>
	Mounting	<b>18</b>
	Probing	<b>22</b>
	Specifications	<b>24</b>
<b>Tool Measurement</b>		
	<b>Selection Guide</b>	<b>34</b>
<b>TT Touch Probe</b>	Principle of Function	<b>37</b>
	Mounting	<b>38</b>
	Probing	<b>39</b>
	Specifications	<b>40</b>
<b>TL Laser System</b>	Components	<b>45</b>
	Mounting	<b>46</b>
	Probing	<b>48</b>
	Specifications	<b>50</b>
<b>Electrical Connection</b>		
<b>Power supply</b>		<b>56</b>
<b>Interfaces</b>	TS, TT Touch Probe	<b>58</b>
	TL Laser Systems, DA 301 TL	<b>60</b>
<b>Universal Touch Probe Interface</b>		<b>62</b>
<b>Cables and Connecting Elements</b>		<b>64</b>

# Application Examples

## Workpiece Alignment

Exact workpiece alignment parallel to the axes is particularly important for partially machined workpieces to ensure that existing datum surfaces are in an accurately defined position. With the TS touch probe systems from HEIDENHAIN you can avoid this time consuming procedure and do without the clamping devices otherwise required.

- The workpiece is clamped in any position.
- The touch probe ascertains the workpiece misalignment by probing a surface, two holes, or two studs.
- The CNC compensates for the misalignment by rotating the coordinate system. It is also possible to compensate for it mechanically by rotating the table.

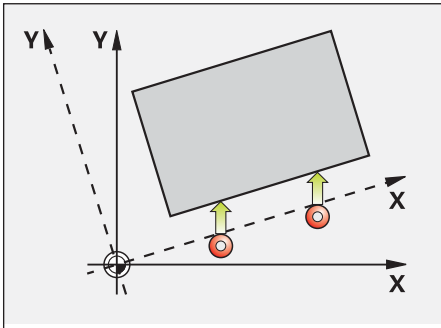

Compensating for misalignment through a basic rotation of the coordinate system

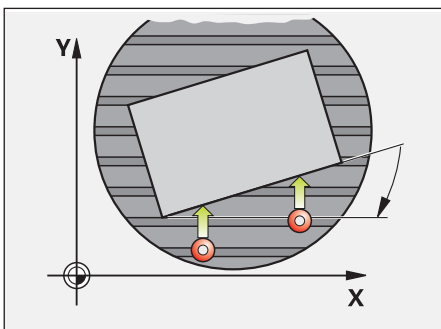

Compensating for misalignment by rotating the table



# Workpiece Presetting



Programs for workpiece machining are based on reference points. Finding this point quickly and reliably with a workpiece touch probe reduces nonproductive time and increases machining accuracy. If probing functions are available on the CNC, the TS touch probes from HEIDENHAIN make it possible to set reference points automatically.

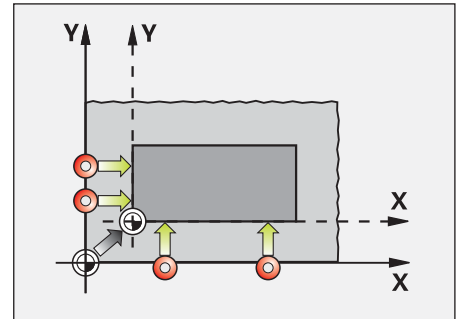

Outside corner

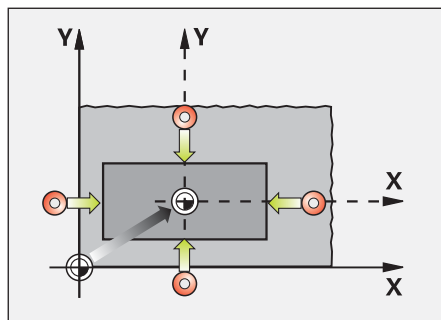

Center of a rectangular stud

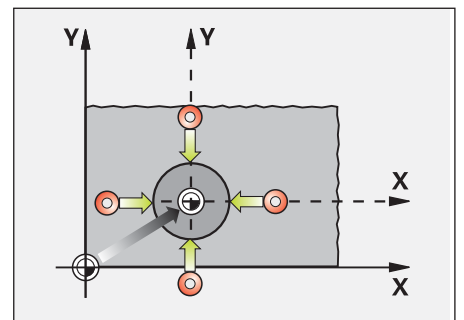

Center of a circular stud

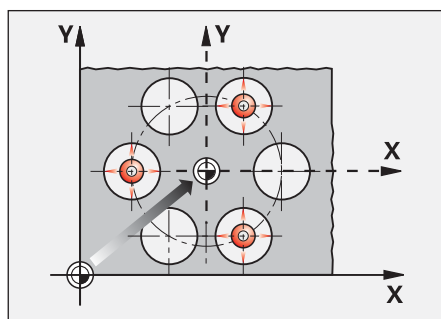

Center of a bolt hole circle

# Workpiece Measurement

Touch probes from HEIDENHAIN are suited for program-controlled workpiece measurement between two machining steps. The resulting position values can be used for tool wear compensation.

When the workpiece is done, the measured values can document dimensional accuracy or serve to record machining trends. The CNC can output the results of measurement through the data interface.

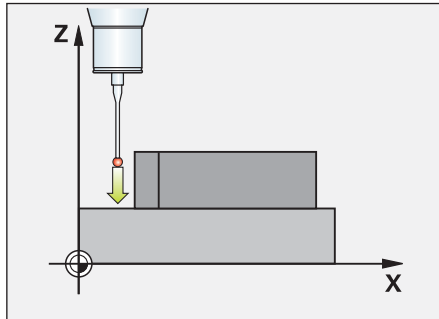

Measuring individual positions in an axis

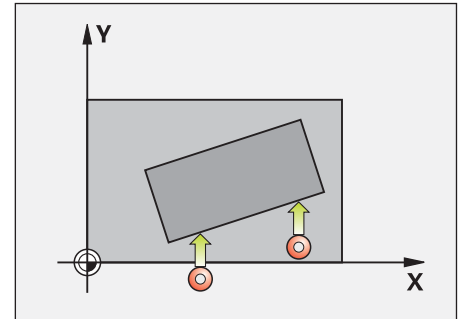

Measuring the angle of a line

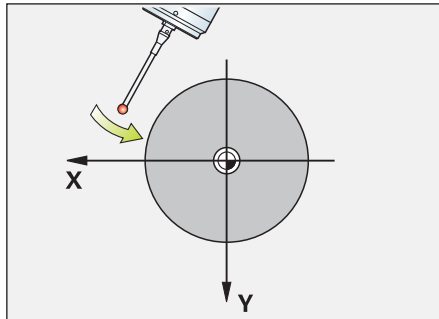

Diameter measurement (with TS 249)

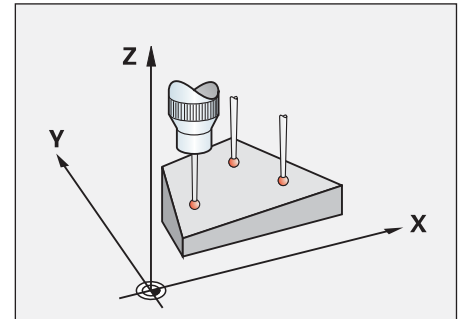

Measuring the angle of a plane

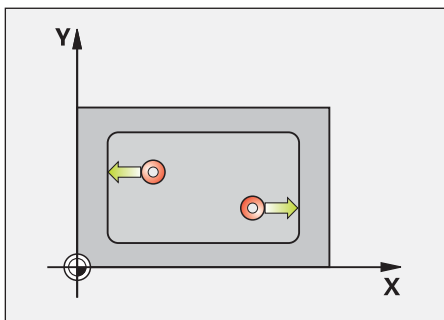

Length measurement

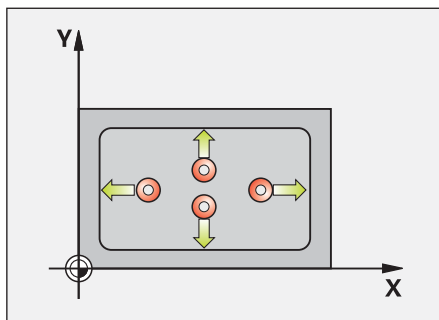

Measuring a rectangular pocket

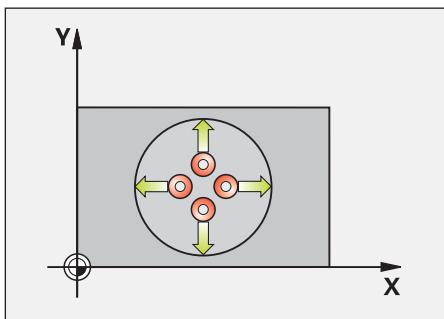

Circular pocket/hole measurement

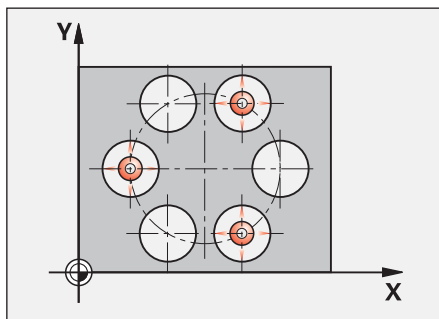

Measuring a bolt hole circle

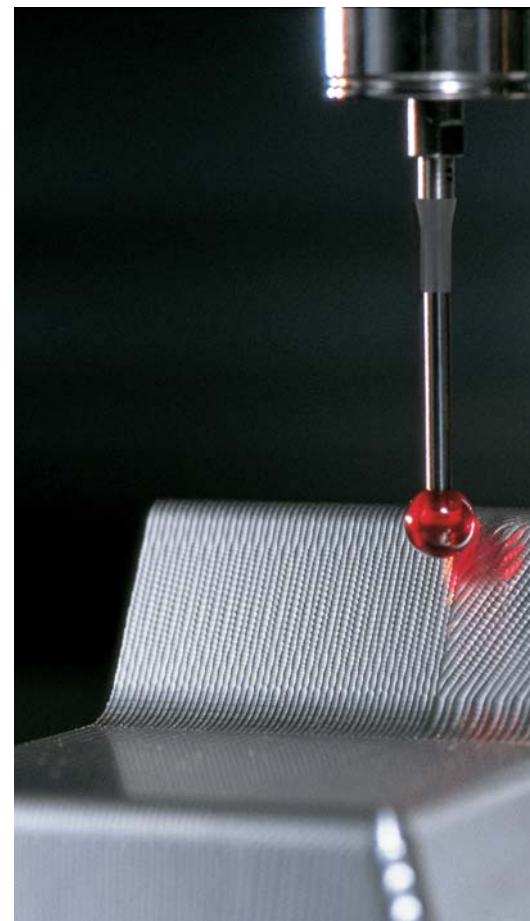

# Practical Examples: Reducing Nonproductive Time

With the aid of external software—e.g. FormControl (software package from Blum-Novotest) or digitizing software—you can digitize models or measure freeform surfaces right at the machine tool. In this way you can detect machining errors immediately and correct them without reclamping. Thanks to their mechanical design and wear-free optical switch, TS touch probes from HEIDENHAIN are ideal for this purpose.

Touch probes from HEIDENHAIN can reduce non-cutting time, improve production quality, prevent scrap, and increase productivity.

To give you a quantitative indication of savings in nonproductive time, two examples of workpiece setup using either a dial gauge or a HEIDENHAIN touch probe are described below.

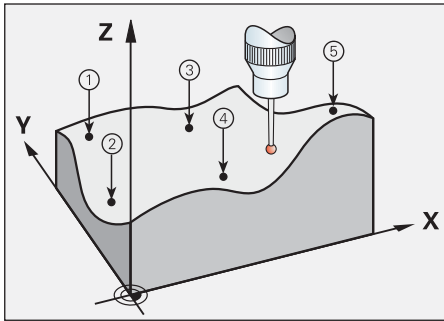

Measuring free-form surfaces

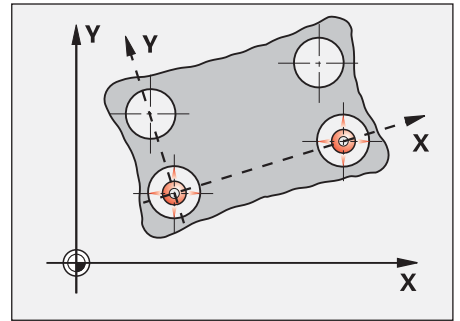
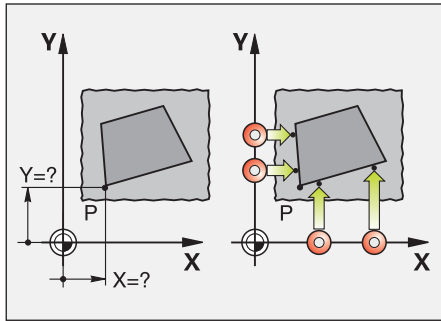

### The task

- Align the workpiece blank parallel to the axes
- Set the datum in the working plane at a corner
- Set the tool axis datum at the top surface of the blank

### The time saved

With a TS touch probe from HEIDENHAIN, this setup operation is performed with a time saving of about four minutes, or approx. 72 %.

You can easily calculate the annual return on investment from your hourly machine cost, the number of workdays per year, and the number of setups performed per day.

### The task

- Align a workpiece paraxially using two holes
- Set the datum of the working plane in the center of the first hole.
- Set the tool axis datum at the top surface of the blank

### The time saved

With a TS touch probe from HEIDENHAIN, this setup operation is performed with a time saving of about five minutes, or approx. 77 %.

You can easily calculate the annual return on investment from your hourly machine cost, the number of workdays per year, and the number of setups performed per day.

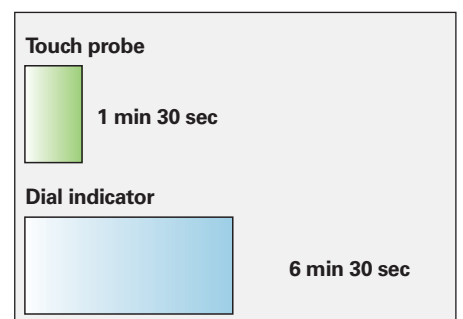
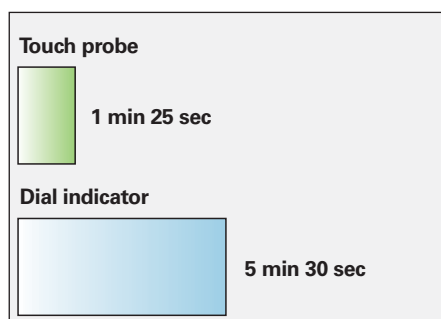



# Tool Measurement with TT Touch Probes

Consistently high machining accuracy requires an exact measurement of tool data and cyclical inspection of tool wear. The TT tool touch probes measure almost any type of tool right on the machine. For milling cut-

ters, it can be used to measure length and diameter, including the dimensions of individual teeth. The CNC automatically saves the results of measurement in the tool memory for use with the part program.

Using a cuboid probe contact, you can also measure turning tools and check them for breakage. For effective tool-tip radius compensation you only need to add the cutter radius to your entries in the CNC.

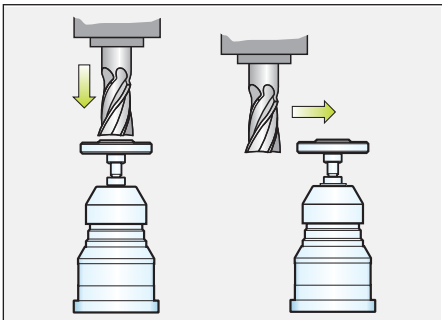

Measuring tool length and radius with stationary or rotating spindle

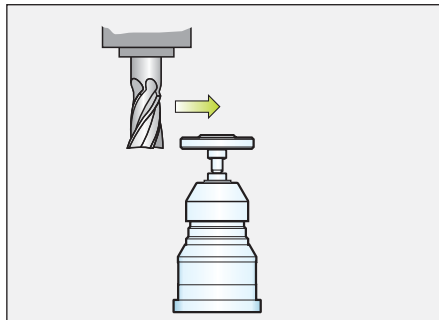

Individual tooth measurement for inspecting indexable inserts (not for hard, brittle teeth)

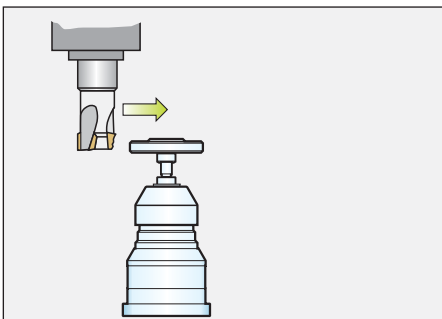

Tool wear measurement

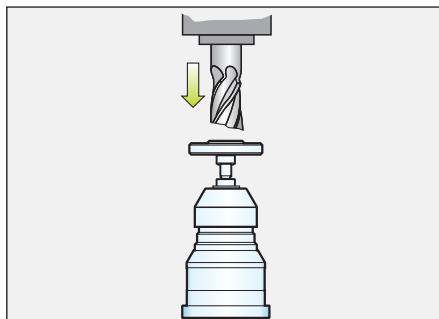

Tool breakage monitoring

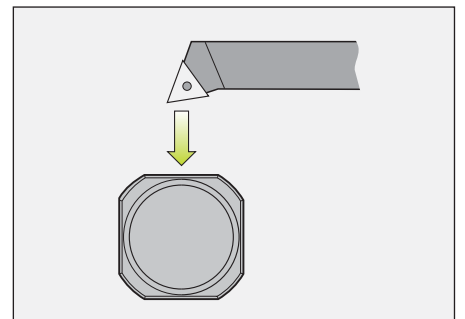

Turning tool measurement



# Tool Measurement with TL Laser Systems

Workpiece measurement with the TL laser system offers special benefits for workpiece measurement. The contact-free measuring method by laser beam enables you to check even the smallest tools rapidly, reliably and without collision. And modern cutting materials of hard, brittle materials are no problem for the TL laser systems.

Because the tool is measured at rated speed, errors on the tool, spindle and holder are detected and corrected directly.

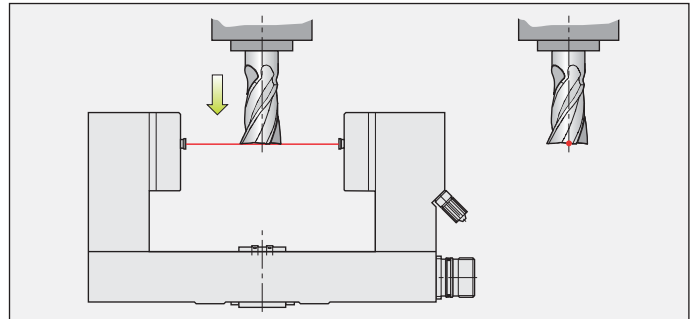

Tool length measurement

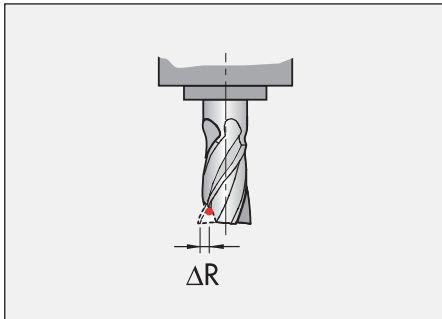

Tool radius measurement, detection of tooth breakage

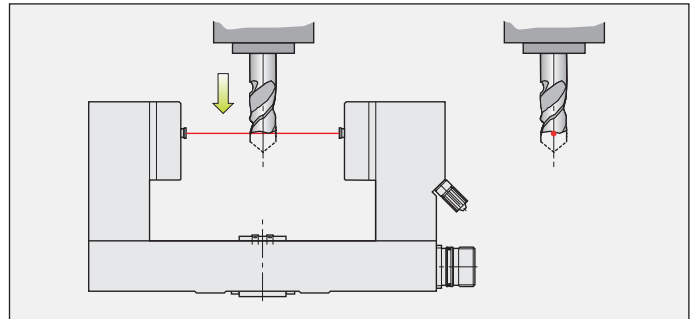

Detection of tool breakage

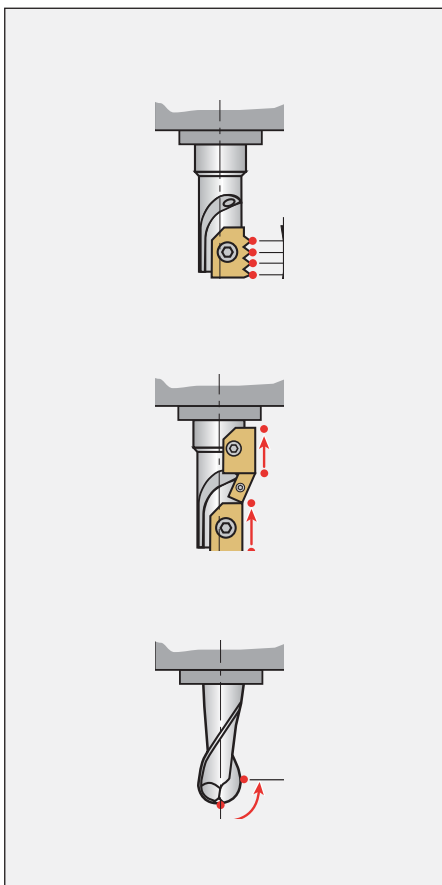

Single tooth and shape inspection



# Selection Guide

The TS workpiece touch probes from HEIDENHAIN help you perform setup, measuring and inspection functions directly on the machine tool.

The stylus of a TS touch trigger probe is deflected upon contact with a workpiece surface. At that moment the TS generates a trigger signal that is transmitted either by cable or over an infrared beam to the control. The control simultaneously saves the actual position values as measured by the machine axis encoders, and uses this information for further processing. The trigger signal is generated through a wear-free optical switch that ensures high reliability.

		TS Touch Probe		
<b>Machine type</b>	<b>CNC machine tool for milling, drilling and boring</b>			
<b>Tool change</b>	<b>Automatic</b>			
<b>Signal transmission</b>	Infrared to SE 540, SE 640, SE 642 transmitter/receiver unit			
<b>Power supply</b>	Batteries, rechargeable or nonrechargeable	Air turbine generator	Batteries, rechargeable or nonrechargeable	
<b>Switching on/off</b>	By infrared signal			Switch in taper shank
<b>Probe repeatability</b>	$2\sigma \leq 1\ \mu\text{m}$			
<b>Interface to control</b>	HTL signal levels via SE transceiver unit			
<b>Type</b>	<b>TS 440</b>	<b>TS 444</b>	<b>TS 640</b>	<b>TS 642</b>

HEIDENHAIN touch probes for workpiece measurement on milling, drilling, boring machine and machining centers are available in various versions:

Touch probes with **infrared signal transmission** for machines with automatic tool change:

**TS 440** – Compact dimensions

**TS 444** – Compact dimensions, battery-free power supply through integrated air turbine generator over central compressed air supply

**TS 640** – Standard touch probe with wide-range infrared transmission

**TS 642** – Same as TS 640, but activated by switch in taper shank

**TS 740** – High probing accuracy and repeatability, low probing force

Touch probes with **cable connection for signal transmission** for machines with manual tool change:

**TS 220** – TTL version

**TS 230** – HTL version

Touch probes for CNC grinding machines or lathes:

**TS 249** – Especially compact dimensions



				<b>CNC grinding machine or lathe</b>
<b>Manual</b>				
Cables				
5 V DC		15 to 30 V DC		
By infrared signal	–			
$2\sigma \leq 0.25\ \mu\text{m}$	$2\sigma \leq 1\ \mu\text{m}$			
TTL		HTL		
<b>TS 740</b>	<b>TS 220</b>	<b>TS 230</b>	<b>TS 249</b>	



## Contents

<b>Principle of Function</b>	Sensor	<b>12</b>
	Accuracy	<b>13</b>
	Signal Transmission	<b>14</b>
	Infrared Transmission Range	<b>15</b>
	Infrared Transmission	<b>16</b>
<b>Mounting</b>	TS Workpiece Touch Probes	<b>18</b>
	Transceiver Unit	<b>21</b>
<b>Probing</b>	General Information	<b>22</b>
	Styli	<b>23</b>
<b>Specifications</b>	TS 440 and TS 444	<b>24</b>
	TS 640, TS 642 and TS 740	<b>26</b>
	SE 540, SE 640 and SE 642	<b>28</b>
	TS 220 and TS 230	<b>30</b>
	TS 249	<b>32</b>

# Principle of Function

## Sensor

### TS 2xx, TS 44x, TS 64x

Touch probes from HEIDENHAIN operate with an optical switch as sensor. A lens system collimates the light generated from an LED and focuses it onto a differential photocell. When the stylus is deflected, the differential photocell produces a trigger signal.

The stylus of the TS is rigidly connected to a plate integrated in the probe housing on a three-point bearing. The three-point bearing ensures the physically ideal rest position.

Thanks to the non-contacting optical switch, the sensor is free of wear. In this way, HEIDENHAIN touch probes ensure high long-term stability with a constantly probe repeatability even after very many measuring processes, as for example with in-process applications.

### TS 740

The TS 740 uses a high-precision pressure sensor. The trigger pulse is obtained through force analysis. The forces acting during probing are processed electronically. This method provides extremely homogeneous probing accuracy over 360°.

With the TS 740, the deflection of the stylus is measured by several pressure sensors that are arranged between the contact plate and the probe housing. When probing a workpiece, the stylus is deflected so that a force acts on the sensors. The signals generated are processed and the trigger signal is produced. The relatively low probing forces provide high probing accuracy and repeatability, while offering precise trigger characteristics in all directions.

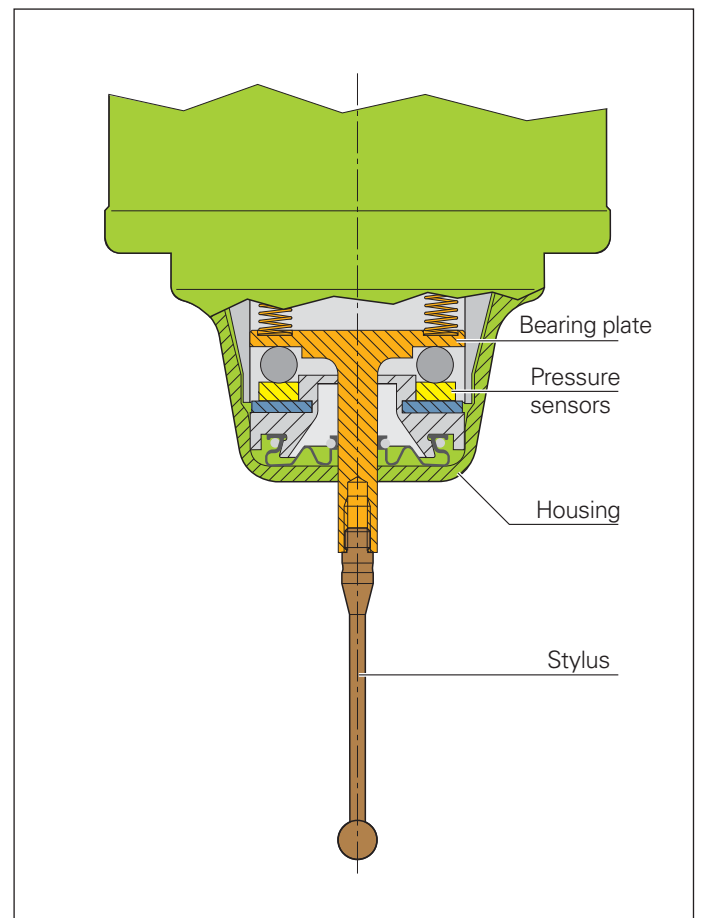
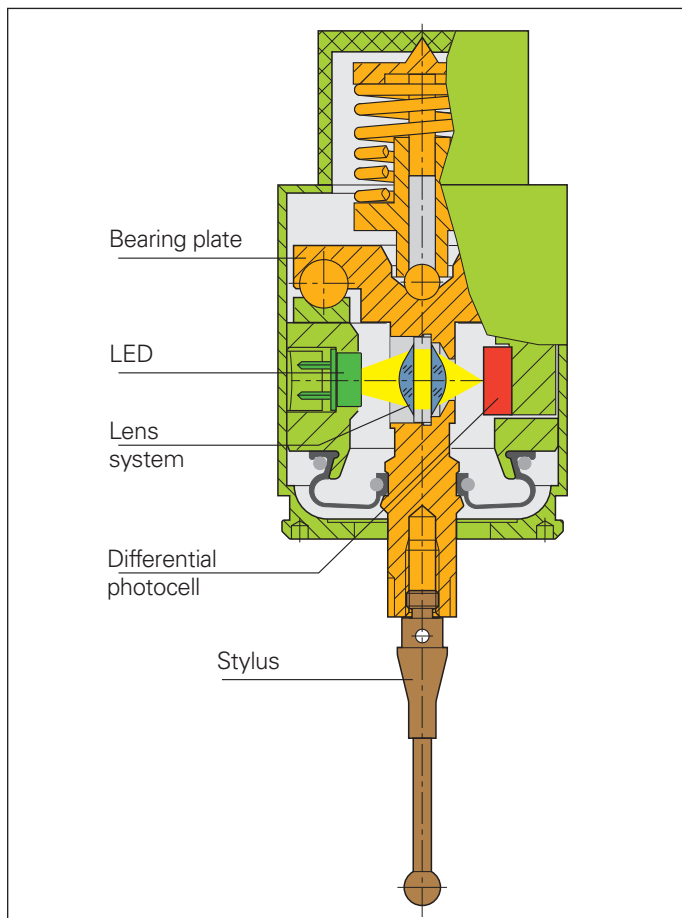

# Accuracy

## Probe accuracy

The probe accuracy specifies the error resulting from probing a test component from **various directions**.

The probing accuracy also includes the effective ball radius. The effective ball radius is calculated from the actual ball radius and the stylus deflection required to produce the trigger signal. This also includes stylus bending.

The probing accuracy of a touch probe is measured at HEIDENHAIN on precision measuring machines. The reference temperature is 22 °C. The stylus used is the T404 (40 mm length, 4 mm ball diameter).

The **TS 740** triggering touch probe is characterized particularly by high probing accuracy and repeatability. These features, together with its low probing force, make the TS 740 suitable for very demanding measuring tasks on machine tools.

## Probe repeatability

Probe repeatability is the dispersion of the results derived from repeated probing **from the same direction**.

## Influence of probe styli

Stylus length and stylus material directly influence the trigger characteristics of a touch probe. Styli from HEIDENHAIN ensure a probing accuracy grade of better than  $\pm 5 \mu\text{m}$ .

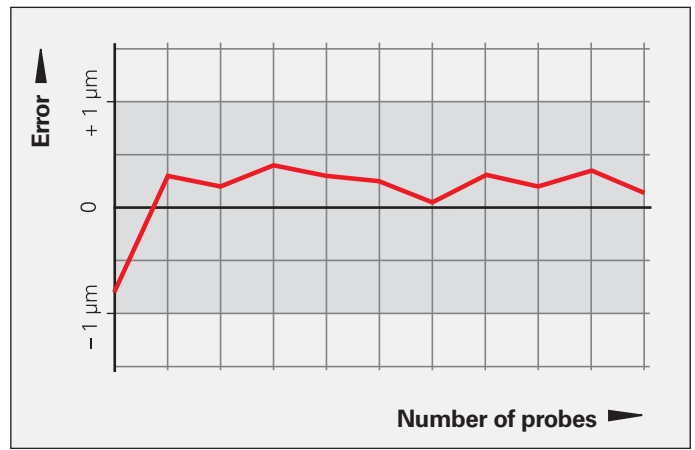

Typical repeatability curve of a TS 2xx/4xx/6xx touch probe: results of repeated probing from one direction at a defined spindle orientation.



**HEIDENHAIN**

**Messprotokoll**  
**Calibration Chart**

**TS 740**  
Id.Nr.: 573757-01  
S.Nr.: 20492261G4

---

Antastabweichung / Probe accuracy grade	X; Y-Achse/Axis: $\pm 0,71 \mu\text{m}$	Antastgeschwindigkeit / Probe velocity: 1 mm/s
Antast-Reproduzierbarkeit / Probe repeatability	X; Y-Achse/Axis: $2 \sigma 0,15 \mu\text{m}$	Bezugstemperatur / Reference temperature: $22^\circ\text{C} \pm 1^\circ\text{C}$

Die Messkurve zeigt die Mittelwerte aus 10 Antastungen pro Antastrichtung.  
Antastabweichung  $\Delta S = S_p - S_M$   
( $S_p = (S_{M\text{max}} + S_{M\text{min}})/2$ ,  $S_M =$  Schaltposition des Prüflings)  
Anzahl der Antastrichtungen: 6

The error curve shows the mean values from ten measurements per probe direction.  
Probe accuracy grade  $\Delta S = S_p - S_M$   
( $S_p = (S_{M\text{max}} + S_{M\text{min}})/2$ ,  $S_M =$  Trigger point of the test component)  
Number of probe directions: 6

<b>Hersteller-Prüfzertifikat (DIN 55 350-18-4.2.2)</b>		<b>Manufacturer's Inspection Certificate (DIN 55 350-18-4.2.2)</b>	
Dieses Gerät wurde unter strengen HEIDENHAIN-Qualitätsnormen hergestellt und geprüft.		This unit has been manufactured and inspected in accordance with the stringent quality standards of HEIDENHAIN.	
Genauigkeitsklasse $\pm 1,0 \mu\text{m}$	Kalibriernormal Laser-Interferometer	Accuracy grade $\pm 1,0 \mu\text{m}$	Calibration standard Laser interferometer
Antast-Reproduzierbarkeit $2 \sigma 0,25 \mu\text{m}$	Kalibrierzeichen 4120 PTB 02	Probe repeatability $2 \sigma 0,25 \mu\text{m}$	Calibration mark 4120 PTB 02
	Kalibrierdatum Juli 2002	Date of calibration	July 2002

# Signal Transmission

## TS 220, TS 230, TS 249 Touch Probes with Signal Transmission by Cable

For these touch probes, both the power supply and the trigger signal are conducted over the touch probe's cable.

The machine operator inserts the TS 220, TS 230 touch probes by hand into the spindle. The spindle must be locked before the touch probe can be inserted (spindle stop). The CNC's probing cycles can run with both vertical and horizontal spindles.

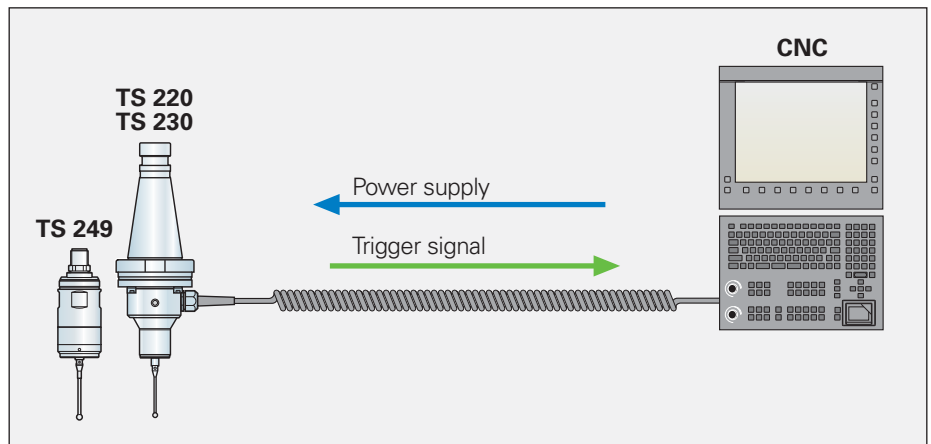

## TS 44x, TS 64x, TS 740 Touch Probes with Infrared Transmission of the Trigger Signal

The TS 44x, TS 64x and TS 740 touch probes transmit the trigger signal through an infrared light beam. This makes them ideal for use on machines with automatic tool changers.

### Infrared beam

The infrared transmission is established between the touch probe and the SE transmitter/receiver unit. The following transceivers are available:

- **SE 540** for integration in the spindle head
- **SE 640** for integration in the machine's workspace
- **SE 642** as common SE for workpiece and tool touch probes

They can be used in any combination with the TS 44x, TS 64x and TS 740.

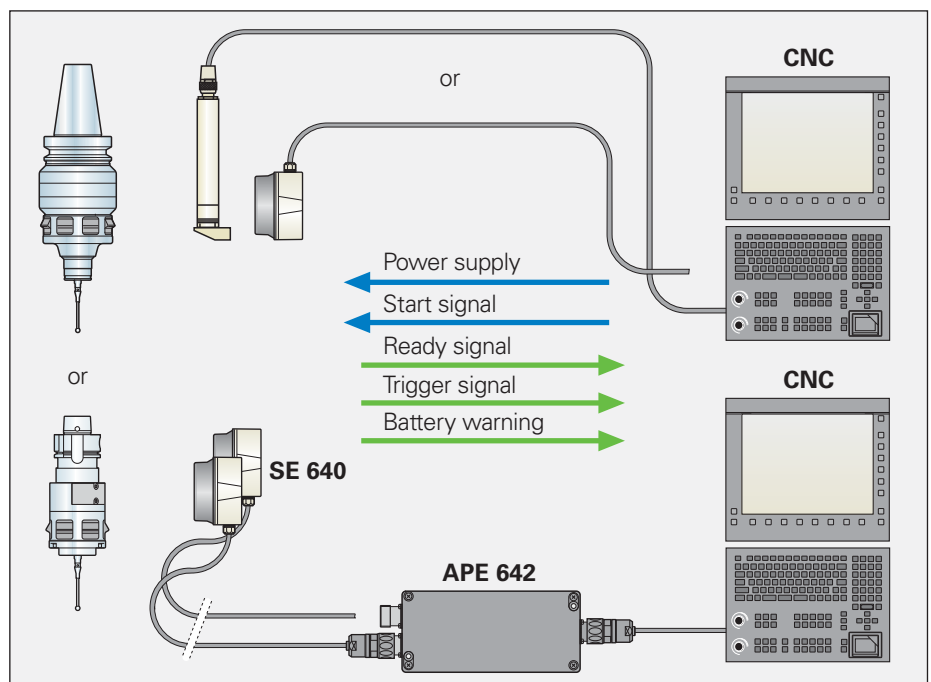

The infrared transmission is tolerant to noise and even works by reflection. It therefore covers a very broad range of applications. For example, the TS 64x can be used both in vertical and horizontal spindles as well as in swivel heads. An even greater infrared transmission range can be realized by combining two SE 640s through an APE 642 interface unit.

The infrared beam transmits several signals: The **start signal** activates the touch probe. With the **ready signal** the touch probe indicates that it is ready for operation. A deflection of the stylus produces the **trigger signal**. If the TS 64x/TS 740's battery capacity falls below 10 %, it transmits a **battery warning**. The falling edge of the start signal switches the touch probe off again.

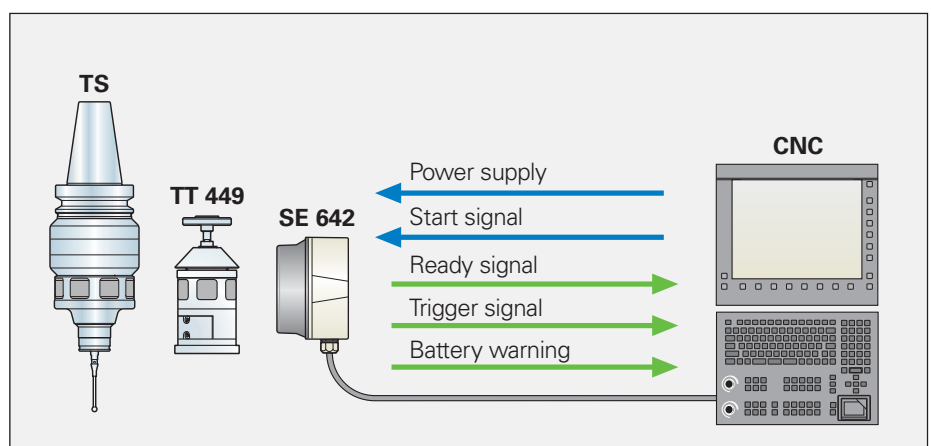

# Infrared Transmission Range

## Transmission area

The transmission areas between the SE transmitter/receiver unit and the touch probes have a lobe form. In order to ensure an optimum signal transmission in both directions, the transceiver should be mounted so that the touch probe is within this range during all operation positions. If the infrared transmission is disturbed or the signal becomes too weak, the SE notifies the CNC through the ready signal. The size of the transmission range depends on both the touch probe and the transceiver used with it.

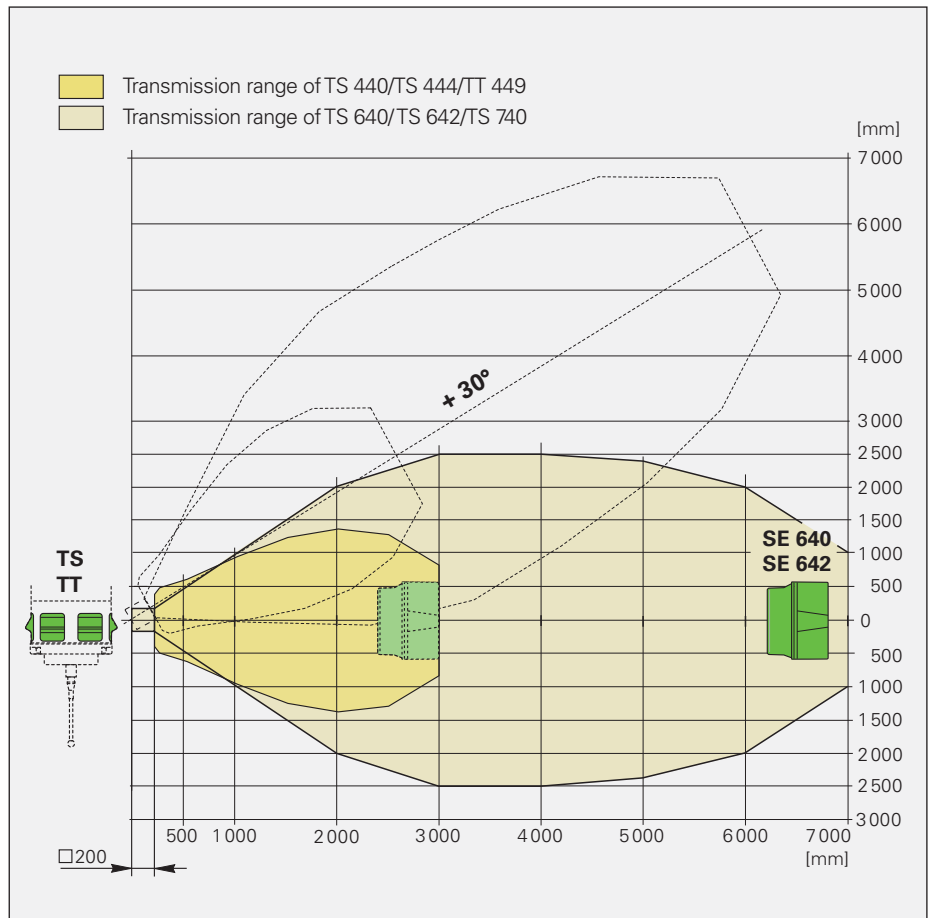
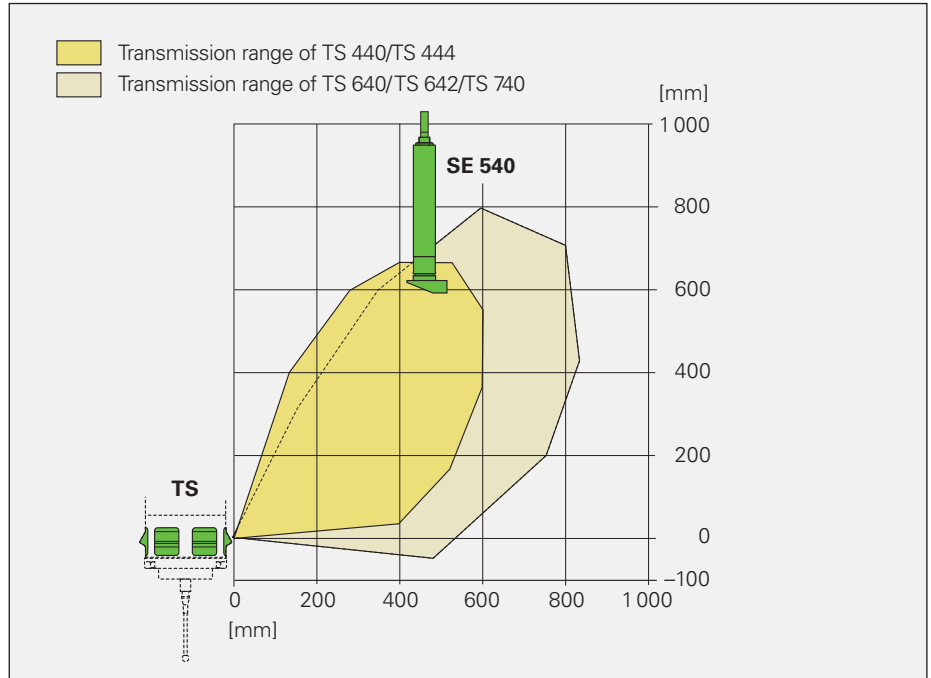



# Infrared Transmission

## 360° transmission range

The LEDs and receiver modules for infrared transmission are evenly distributed on the circumference of the TS touch probe. This ensures a 360° transmission range for reliable reception without previous spindle orientation.

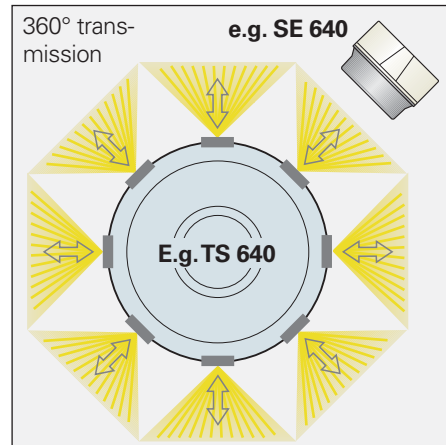

## Angle of transmission

To enable the touch probes with infrared transmission to adapt to varying machine designs, they are available with transmission elevations of 0° or +30°.

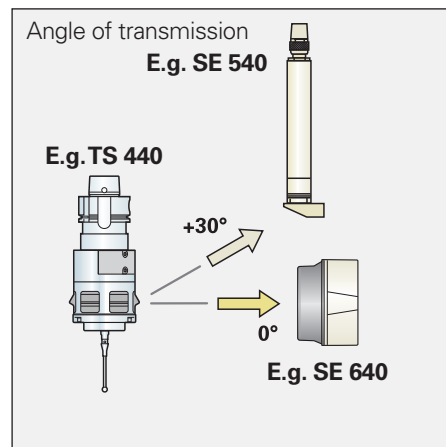

## Optical status indicator of the TS

The touch probes with infrared transmission are equipped with LEDs that, in addition to the output signals, optically indicate the status of the touch probe (readiness and deflection):

- Touch probe is ready: LEDs blink slowly
- Touch probe is deflected: LEDs blink quickly.

This enables you to check the touch probe status at a glance.

## Optical status indicators on the SE 540

The SE 540 transceiver features one multi-color LED indicator that continuously displays the condition of the touch probe (deflection and battery capacity).



### Touch probe or output

Touch probe ready, stylus at rest	● Green
Touch probe ready, stylus deflected	● Orange
<i>On continuously:</i> Battery capacity < 10 % / Battery exchange	● Red
<i>Blinking:</i> Touch probe is not ready	

### Optical status indicators on the SE 640

The SE 640 transceiver features two multi-color LED indicators that continuously display the condition of the infrared transmission and the touch probe (deflection and battery capacity). Because they show at a glance the status of the transmission beam, they are particularly helpful during installation of the receiver units.

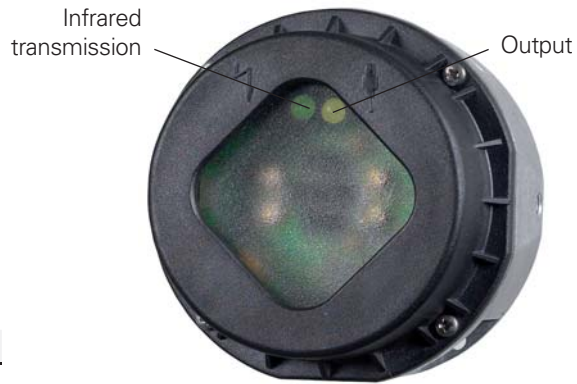

Touch probe or output	
Touch probe ready, stylus at rest	● Green
Touch probe ready, stylus deflected	● Orange
Battery capacity < 10 % / Battery exchange	● Red
Touch probe is not ready	○ Off
Infrared transmission	
OK	● Green
Acceptable	● Orange
Not acceptable	● Red

### Optical status indicators on the SE 642

The SE 642 transmitter/receiver unit features several multicolor LED indicators that make comprehensive diagnostics possible. These include the quality of infrared transmission and the status of the active touch probe, as well as extensive error analysis. The SE 642 also checks whether the signals have actually been transmitted by the touch probe to which the start signal was sent. This can be seen from the "output" status indicator that normally shows the same information as the respective touch probe LED.

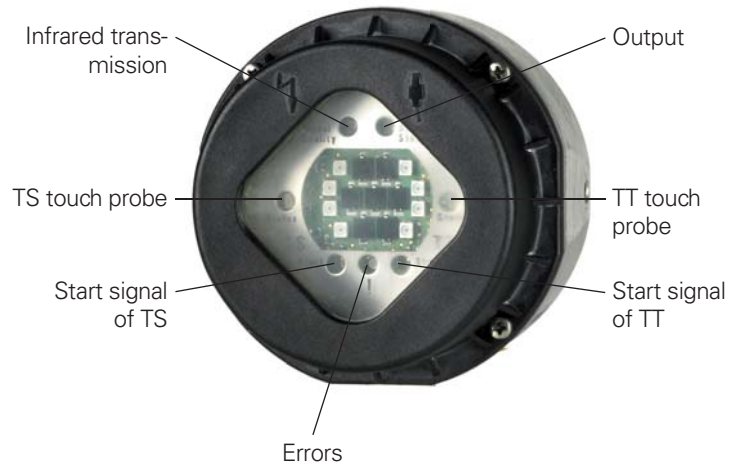

Touch probe or output	
Touch probe ready, stylus at rest	● Green
Touch probe ready, stylus deflected	● Orange
Battery capacity < 10 % / Battery exchange	● Red
Touch probe not ready / output not active	○ Off
Infrared transmission	
OK	● Green
Acceptable	● Orange
Not acceptable	● Red
Start signal	
Start line active	● Orange
Start line not active	○ Off
Error	
Normal function, no error	○ Off
Disturbance in received infrared signal	● Orange
Temporary interruption of IR connection	● Red
More than one touch probe or both start lines active	● Blue

# Mounting

## TS Workpiece Touch Probes

### Taper shanks

The TS workpiece touch probes are inserted directly into the machine spindle. An assortment of taper shanks is delivered with the TS for use with various clamping systems. Please indicate the model when ordering.

The TS touch probes can also be supplied without clamping shank. In this case, the shank is connected through a thread.

- M30 x 0.5 for TS 220/TS 230, TS 640/TS 740
- M12 x 0.5 for TS 440/TS 444

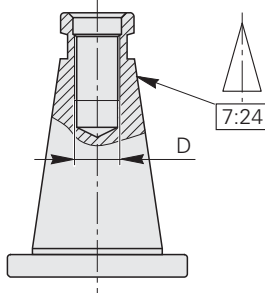
**DIN 2080**  
Taper **D**  
Type

For TS 220/TS 230

Type	D	Type
SK-A 40	M16	S51
SK-A 45	M20	S65
SK-A 50	M24	S52
SK-A 50	UNC 1.000-8	S62

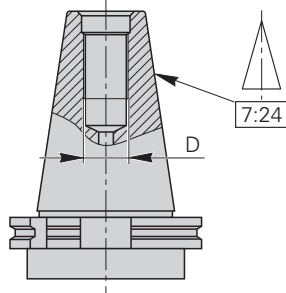

**DIN 69871**  
Taper **D** **Type**

For TS 220/TS 230

SK-A 40	M16	S53
SK-A 45	M20	S64
SK-A 50	M24	S55

For TS 44x/TS 64x/TS 740

SK-AD/B 30	M12	S48/P48
SK-AD/B 40	M16	S81/P81
SK-AD/B 45	M20	S95
SK-AD/B 50	M24	S75/P75

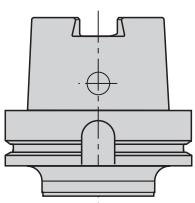

**DIN 69893**  
Taper **Type**

For TS 2xx

HSK-A 63	S77
HSK-A 100	S80

For TS 44x/TS 64x/TS 740

HSK-E 32	S97/P97
HSK-A 40	S92/P92
HSK-E 40	S94
HSK-A 50	S49/P49
HSK-E 50	S68
HSK-A 63	S69/P69
HSK-A 80	S39
HSK-A 100	S72/P72

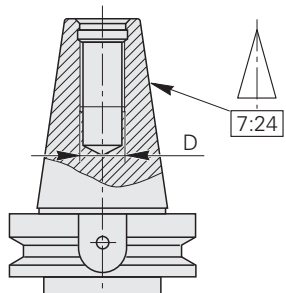

**JIS B 6339**  
Taper **D** **Type**

For TS 220/TS 230

BT 40	M16	S59
BT 50	M24	S54

For TS 44x/TS 64x/TS 740

BT 40	M16	S88/P88
BT 50	M24	S40/P40

### Please note:

Taper shanks identified with **Pxx** (with integrated switch) are available for the **TS 642**.

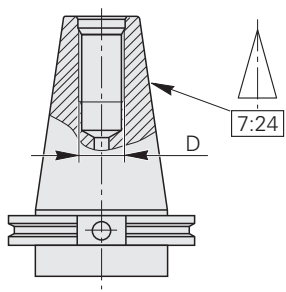

**ASME B5.5**  
Taper **D** **Type**

SK 50	UNC 1x000-8	S42/P42
-------	-------------	---------

## Tool holders

If you use other shanks, the touch probes can be held by standardized straight shanks in commercially available collets. Straight shanks are available for the following tool holders:

- Weldon or shrink-fit chuck as per DIN 6535-HB16
- Whistle notch as per DIN 6535-HE16

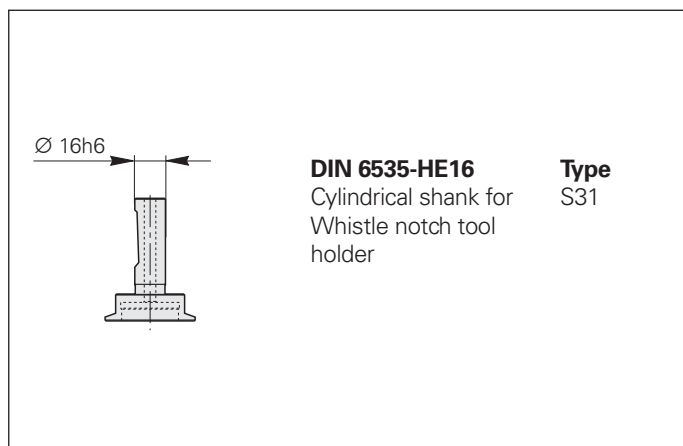
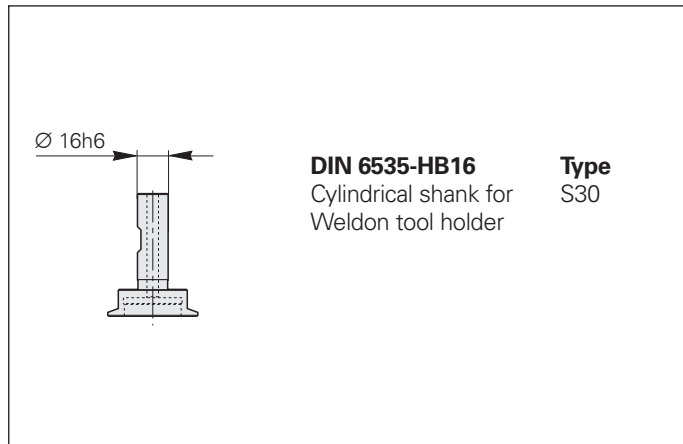

## Mounting accessories

If you purchase the touch probe without clamping shank and instead mount the shank by the connecting thread, HEIDENHAIN offers the following mounting accessories:

### Mounting wrench

For mounting a clamping shank to the  
*TS 440/TS 444*: ID 519873-01  
*TS 640/TS 740*: ID 519833-01

### M12/M30 threaded ring

For adapting the taper shanks and tool holders with an M30 thread to the TS 44x (M12 x 0.5)  
ID 391 026-01

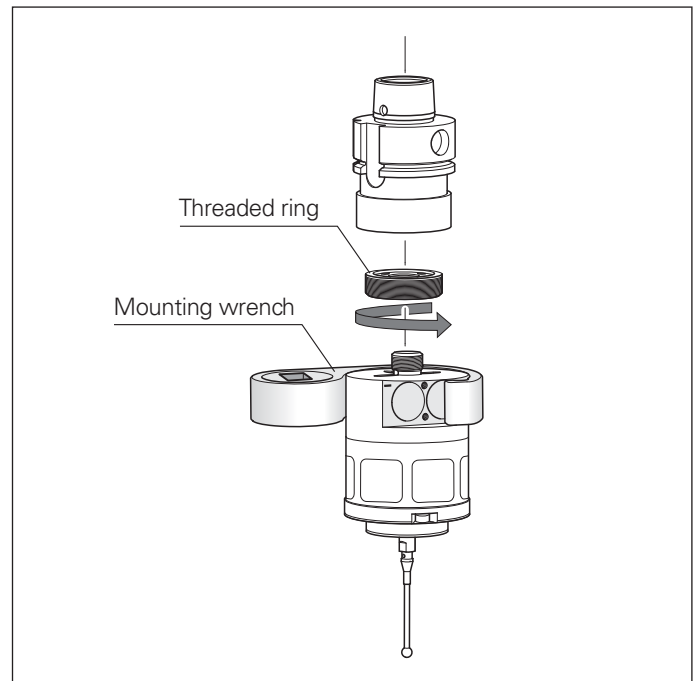

# TS 249

Due to its compact dimensions—the outside diameter is only 30 mm—the TS 249 is even suited for limited installation space. Its high degree of protection (IP 67) and a two-fold sealing system enable its use directly on the machine. The service-friendly design permits quick and easy replacement of the external seal.

The TS 249 is usually mounted to a machine element with the aid of a coupling joint (available as an accessory), a mounting base, or a tilting device. If the fastening element is rotatable, the TT 249 can also be fastened directly with its M28 x 0.75 outside thread.

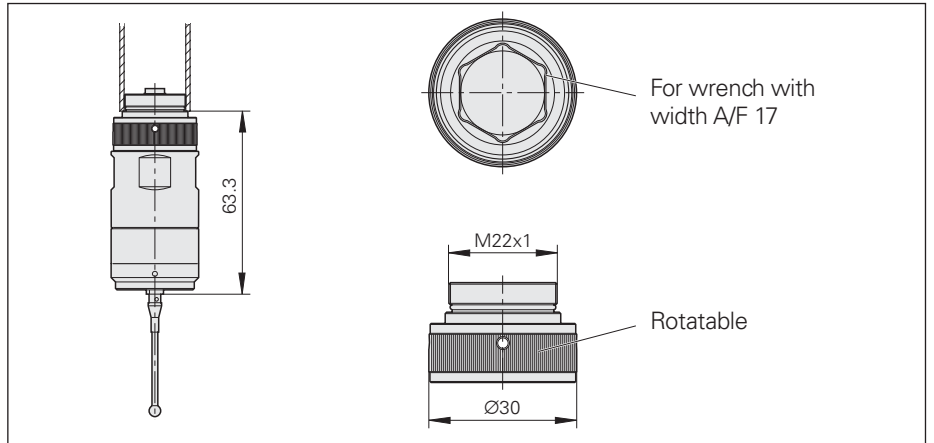

With the aid of the coupling joint, the TS 249 can also be rotated as desired on a rigid fastening element. This enables you, for example, to align the TS 249 with an asymmetric or cuboid probe contact exactly parallel to the machine axes.

Accessory:

**Coupling joint**

M22x1 outside thread

ID 643089-01

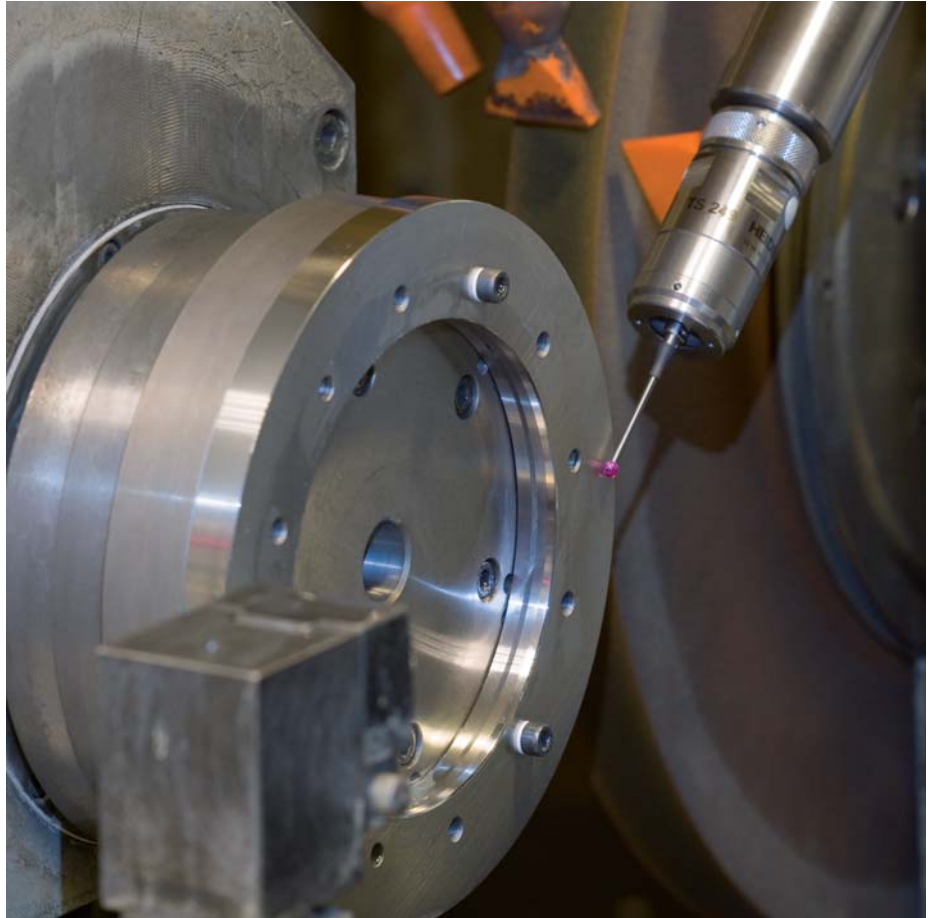

# Transceiver Unit

The SE transmitter/receiver unit is to be mounted so that it remains within the transmission range of the touch probe over the machine's entire range of traverse.

## SE 540 transmitter/receiver unit

The SE 540 is intended for integration in the spindle head. Except for a few cases, for example on machines with quills, this ensures transmission on machines with very large traverse ranges or with swivel heads. The transmission range of the infrared signal is appropriate to the mounting location. Because the SE 540 is always above and to the side of the TS, HEIDENHAIN recommends using touch probes with +30° transmission angle. The machine must be designed to support the SE 540.

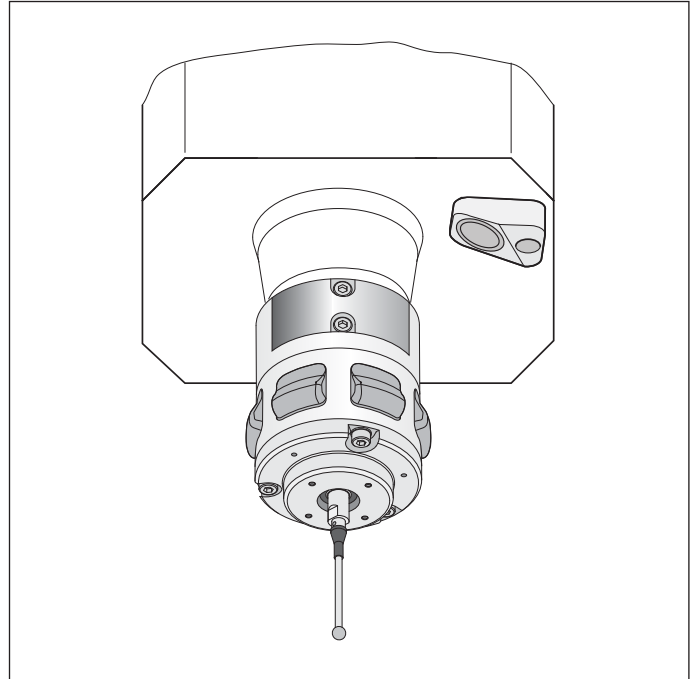

## SE 640, SE 642 transmitter/receiver unit

The SE 64x is mounted at a suitable location in the machine's workspace. It is also easily to retrofit. Thanks to its high IP 67 degree of protection, it can also tolerate coolant. A holder to facilitate mounting is available as an accessory. When mounting the SE 642 it is important to note that it can communicate both with the TS workpiece touch probe and with the TT 449 tool touch probe. The touch probes' very large angular range of transmission (up to 7 m with the TS 640) allows reliable transmission to machines with long axes.

For special applications, for example very large machines, the transmission range can be enlarged by installing a second SE 640. The connected APE 642 interface electronics unit evaluates the infrared signals so that the NC receives only one trigger signal regardless of the working range in which the touch probe is located.

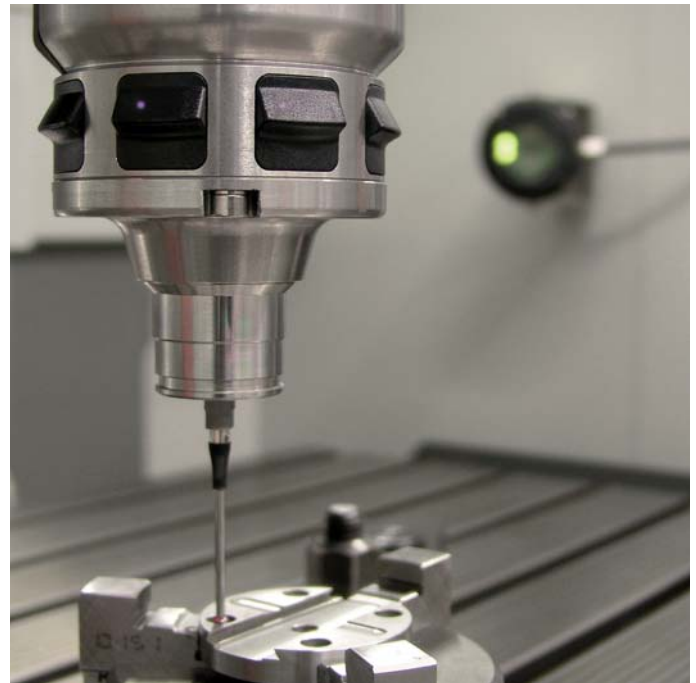

## Mounting accessories

Mounting bracket for SE 64x ID 370827-01

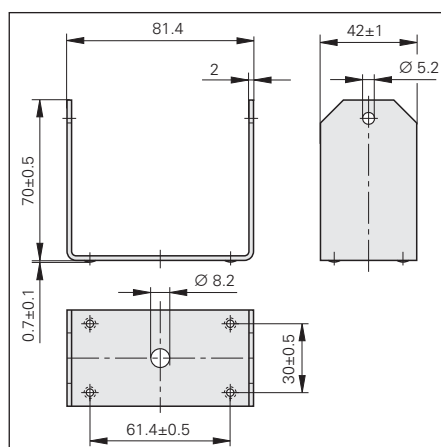

# Probing

The workpiece geometry or position is ascertained by the TS workpiece touch probe through mechanical probing. To ensure correct measurement, the workpiece should be free of chips and other foreign matter.

Upon deflection of the stylus a trigger signal is transmitted to the control. In addition, the deflection is indicated by LEDs

- with continuous light on the TS 220/ TS 230
- with fast blinking light on the touch probes with infrared transmission.



The touch probes with infrared transmission feature an integrated **cleaning blower/flusher**: The probing point can be cleaned of loose particles with the aid of compressed air or cooling liquids through three jets at the bottom of the probe. Even chip accumulation in pockets is no problem. This allows automatic measuring cycles during unattended operation. The cleaning blower can only work on machines with a compressed-air or cooling fluid duct through the spindle.

On the battery-free TS 444 touch probe, the compressed air is used at the same time to charge the capacitors.

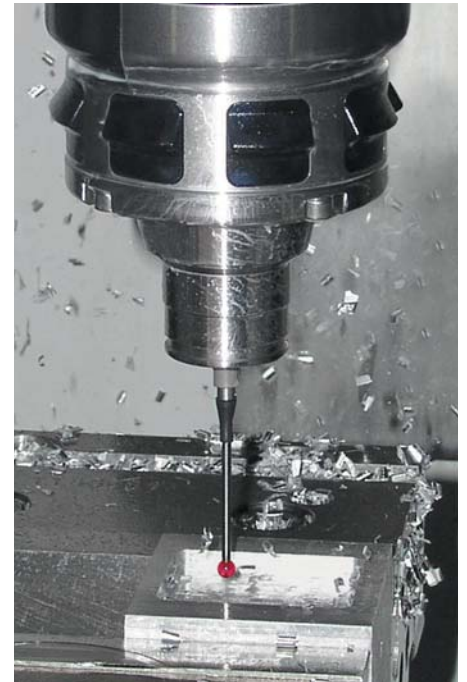

## Probe velocity

Signal propagation times in the CNC influence the probe repeatability of the touch probe. Besides the signal propagation time, the permissible stylus deflection must also be considered. The mechanically permissible probing velocity is shown in the specifications.

## Deflection of probe contact

The maximum permissible deflection of the stylus is 5 mm in any direction. The machine must stop moving within this distance to avoid damaging the touch probe.

Deflection of the stylus

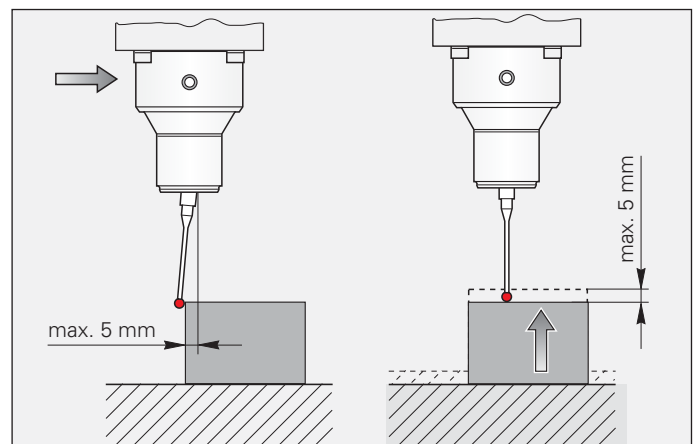

# Styli

## Styli for TS

HEIDENHAIN offers probe styli with various ball-tip diameters and stylus lengths. All styli are attached to the TS touch probes with an M3 thread. Starting from a ball-tip diameter of 4 mm, a rated breaking point protects the touch probe from mechanical damage caused by operator error. The T404 and T424 styli are included with the TS touch probe.

With the aid of the adapter provided with delivery, M4 styli are also usable on the **TS 249**. By using the coupling joint, the TS 249 can be rotated into position in order to align asymmetric or cuboid probe contacts exactly.

### Ball-tip styli

Type	ID	Length l	Ball dia. D
T421	295770-21	21 mm	1 mm
T422	295770-22	21 mm	2 mm
T423	295770-23	21 mm	3 mm
T424	352776-24	21 mm	4 mm
T404	352776-04	40 mm	4 mm
T405	352776-05	40 mm	5 mm
T406	352776-06	40 mm	6 mm
T408	352776-08	40 mm	8 mm

### Stylus extension

Type	ID	Length l	Material
T490	296566-90	50 mm	Steel

The stylus extension must be used only together with the short styli (21 mm length).

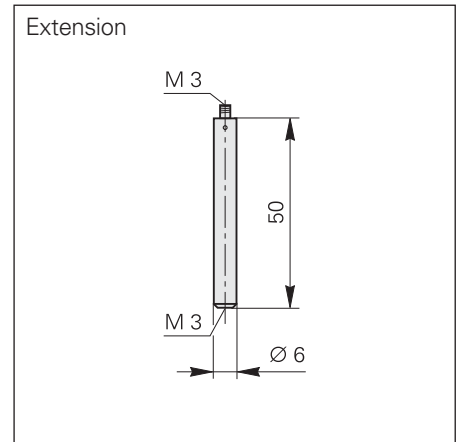
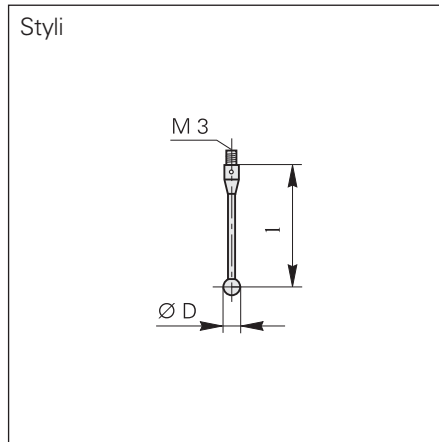



# TS 440 and TS 444

Workpiece Touch Probes with Infrared Transmission



TS 440



TS 444

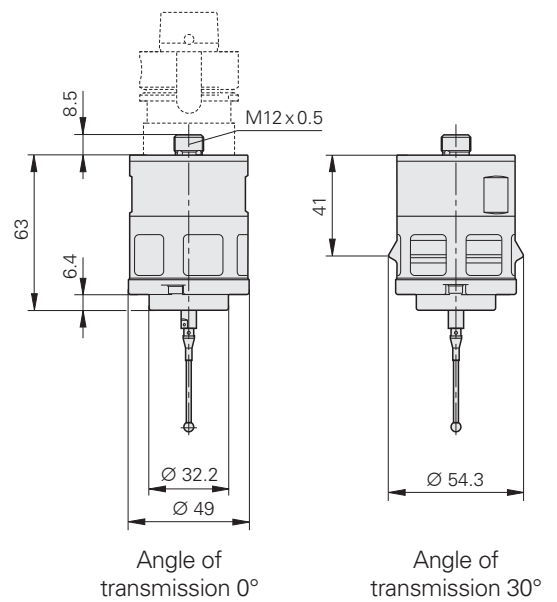
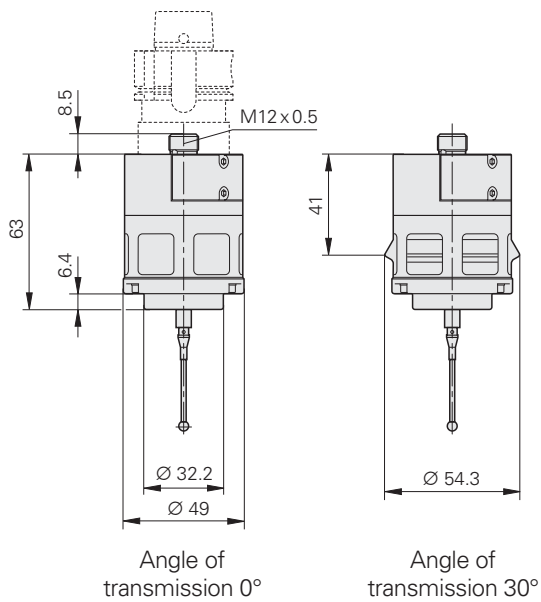

mm  
  
 Tolerancing ISO 8015  
 ISO 2768 - m H  
 < 6 mm:  $\pm 0.2$  mm

Workpiece touch probe	TS 440	TS 444
<b>Probe accuracy</b>	≤ ± 5 µm when using a standard stylus	
<b>Probe repeatability</b> Repeated probing from one direction	2 σ ≤ 1 µm at a probing velocity of 1 m/min <i>Typical values:</i> 2 σ ≤ 1 µm at a probing velocity of 3 m/min 2 σ ≤ 4 µm at a probing velocity of 5 m/min	
<b>Deflection of probe contact</b>	≤ 5 mm in all directions (with stylus length L = 40 mm)	
<b>Deflection force</b>	Axial: Approx. 7 N Radial: 0.7 to 1.3 N	
<b>Probe velocity</b>	≤ 5 m/min	
<b>Protection EN 60529</b>	IP 67	
<b>Operating temperature</b>	10 °C to 40 °C	
<b>Storage temperature</b>	-20 °C to +70 °C	
<b>Weight</b> without taper shank	Approx. 0.4 kg	
<b>Taper shank*</b>	<ul style="list-style-type: none"> <li>• With taper shank* (overview on page 18)</li> <li>• W/o taper shank (connecting thread M12 x 0.5)</li> </ul>	
<b>Signal transmission</b>	Infrared transmission with 360° range	
<b>Transmission angle of infrared signal*</b>	0° or +30°	
<b>Transmitter/receiver unit*</b>	SE 540 or SE 640	
<b>Switching the TS on/off</b>	Infrared signal from SE	–
<b>Power supply:</b>	Batteries, rechargeable or nonrechargeable	Compressed air Recommended operating pressure 5.5 x 10 <sup>5</sup> to 8 x 10 <sup>5</sup> Pa
Energy buffer	2 batteries (rechargeable or nonrechargeable), size 2/3 AA or size N <sup>1)</sup> each 1 V to 4 V	Integrated high-power capacitors; charging time typically 3 s at 5.5 x 10 <sup>5</sup> Pa
Operating time	Continuous duty typically 200 h with lithium batteries <sup>2)</sup> 3.6 V/1 200 mAh	Typically 120 s

\* Please select when ordering

<sup>1)</sup> Via adapter, included in delivery

<sup>2)</sup> Included in delivery

10<sup>5</sup> Pa ≙ 1 bar

# TS 640, TS 642 and TS 740

Workpiece Touch Probes with Infrared Transmission



TS 640/TS 642



TS 740

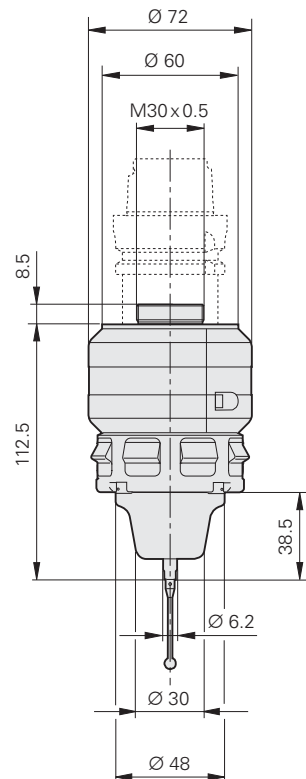
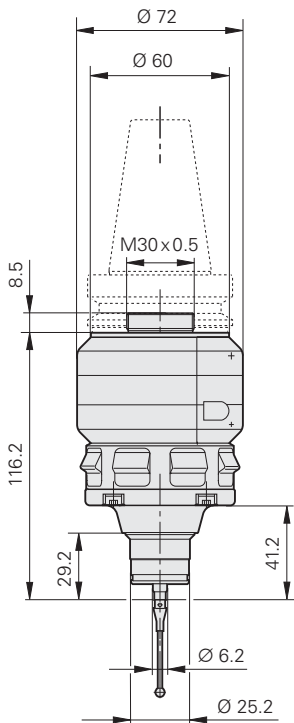

mm  
  
 Tolerancing ISO 8015  
 ISO 2768 - m H  
 < 6 mm: ±0.2 mm

Workpiece touch probe	TS 640	TS 642	TS 740
<b>Probe accuracy</b>	≤ ± 5 µm when using a standard stylus		≤ ± 1 µm when using a standard stylus
<b>Probe repeatability</b> Repeated probing from one direction	2 σ ≤ 1 µm at a probing velocity of 1 m/min <i>Typical values:</i> 2 σ ≤ 1 µm at a probing velocity of 3 m/min 2 σ ≤ 4 µm at a probing velocity of 5 m/min		2 σ ≤ 0.25 µm at a probing velocity of 0.25 m/min
<b>Deflection of probe contact</b>	≤ 5 mm in all directions (with stylus length L = 40 mm)		
<b>Deflection force</b>	Axial: Approx. 8 N Radial: approx. 1 N		Axial: Approx. 0.6 N Radial: approx. 0.2 N
<b>Probing velocity</b>	≤ 5 m/min		≤ 0.25 m/min
<b>Protection EN 60529</b>	IP 67		
<b>Operating temperature</b>	10 °C to 40 °C		
<b>Storage temperature</b>	-20 °C to +70 °C		
<b>Weight</b> without taper shank	Approx. 1.1 kg		
<b>Taper shank*</b>	<ul style="list-style-type: none"> <li>• With taper shank* (overview on page 18)</li> <li>• Without taper shank (connecting thread M30 x 0.5), not with TS 642</li> </ul>		
<b>Signal transmission</b>	Infrared transmission with 360° range		
<b>Transmission angle of infrared signal*</b>	0° or +30°		
<b>Transmitter/receiver unit*</b>	SE 540 or SE 640		
<b>TS switch-on/off</b>	Infrared signal from SE	Via switch in taper shank	Infrared signal from SE
<b>Power supply</b>	Two rechargeable or nonrechargeable batteries, 1 V to 4 V each, size C or size A <sup>1)</sup>		
Battery life <sup>2)</sup> (typically)	800 h	800 h <sup>3)</sup>	500 h

\* Please select when ordering

<sup>1)</sup> Via adapter, included in delivery

<sup>2)</sup> In continuous operation with lithium batteries, 3.6 V/6000 mAh; with the lithium batteries, size A, included in delivery only half the service life is reached

<sup>3)</sup> Reduced service life as replacement for TS 632

# SE 540, SE 640 and SE 642

Transmitter/Receiver Units for Workpiece Touch Probes with Infrared Transmission



**SE 540**

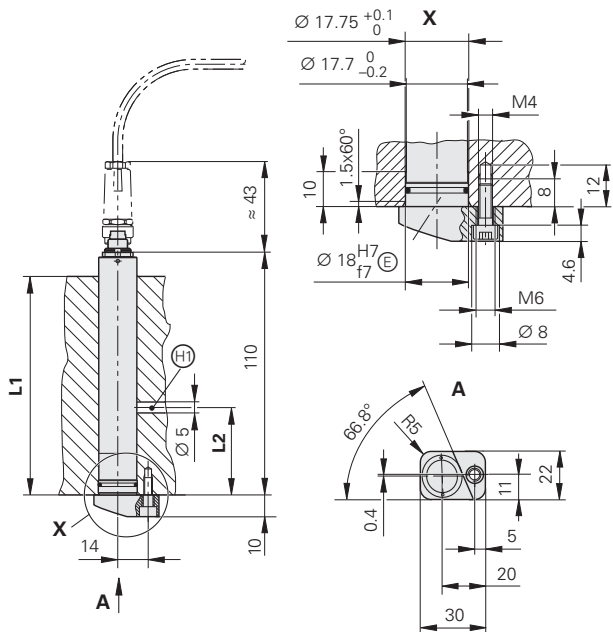

Ⓜ = Metal armor  
ⓐ = O-ring 16x1

**SE 640/SE 642**

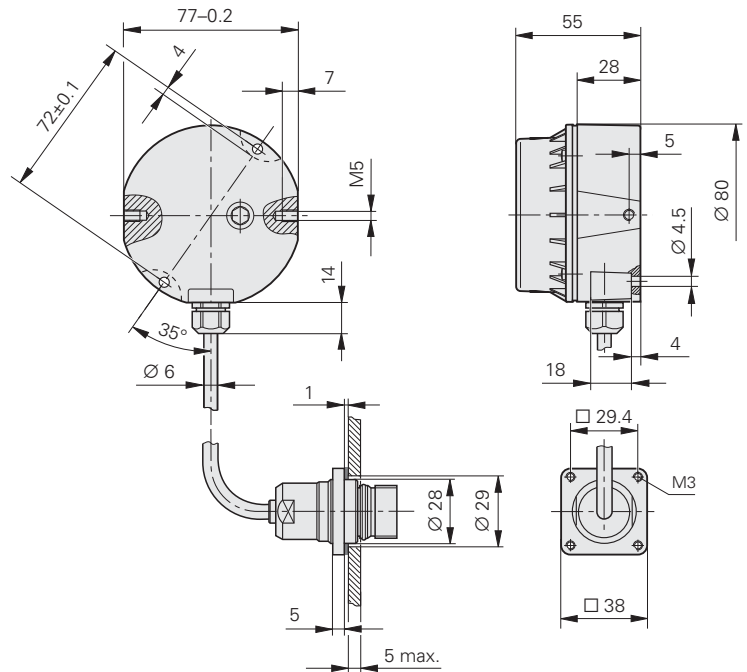

mm  
 Tolerancing ISO 8015  
 ISO 2768 - m H  
 < 6 mm: ±0.2 mm

Transceiver unit	SE 540	SE 640	SE 642
<b>Area of application</b>	In the mating hole In the spindle	In working space of machine	In the machine's working space; for common communication with TS and TT 449 using infrared transmission
<b>Input/output signals</b>	Square-wave signals at HTL level <ul style="list-style-type: none"> <li>• Start signal R</li> <li>• Ready signal B</li> <li>• Trigger signal <math>\overline{S}</math></li> <li>• Battery warning <math>\overline{W}</math></li> </ul>		Square-wave signals at HTL level <ul style="list-style-type: none"> <li>• Start signals R(-TS) and R(-TT)</li> <li>• Ready signals B(-TS) and B(-TT)</li> <li>• Trigger signals S and <math>\overline{S}</math></li> <li>• Battery warning <math>\overline{W}</math></li> </ul>
<b>Optical status indicator</b>	For touch probe	For infrared transmission and touch probe	For infrared transmission, errors and whether workpiece or tool touch probe
<b>Protection</b> EN 60529	IP 67		
<b>Operating temperature</b>	$U_P = 15\text{ V}$ : 10 °C to 60 °C $U_P = 30\text{ V}$ : 10 °C to 40 °C	10 °C to 40 °C	
<b>Storage temperature</b>	-20 °C to +70 °C		-20 °C to +70 °C
<b>Weight</b> without cable	Approx. 0.1 kg	Approx. 0.2 kg	
<b>Power supply</b>	15 to 30 V DC		
<b>Current consumption</b> without load Normal operation Transmission (max. 3.5 s)	$\leq 75\text{ mA}$ $\leq 100\text{ mA}_{\text{eff}}$	$\leq 170\text{ mA}$ $\leq 250\text{ mA}_{\text{eff}}$	$5.1\text{ W}_{\text{eff}} (\leq 250\text{ mA}_{\text{eff}}^{1})$ $8.3\text{ W} (\leq 550\text{ mA}^{1})$
<b>Electrical connection*</b>	M9 flange socket, 8-pin	<ul style="list-style-type: none"> <li>• Cable 0.5 m with M23 mounted coupling</li> <li>• Cable 2 m with M23 coupling</li> <li>• Cable in protective sleeve, 3 m, with M23 mounted coupling</li> </ul>	Cable 0.5/2 m with 12-pin M12 connector
<b>Max. cable length</b>	30 m with adapter cable $\varnothing 4.5\text{ mm}$ 50 m with adapter cable $\varnothing 4.5\text{ mm}$ and adapter cable $\varnothing 8\text{ mm}$ for extension	50 m	50 m 20 m with iTNC 530

\* Please select when ordering

<sup>1)</sup> At minimum supply voltage

# TS 220 and TS 230

Workpiece Touch Probes with Cable Connection

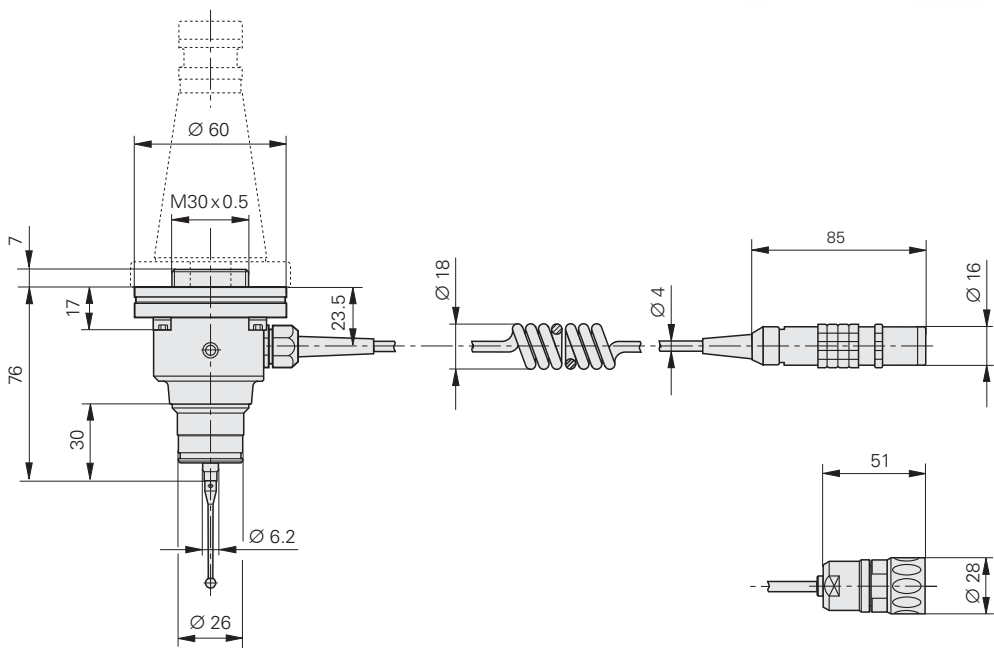

mm  
Tolerancing ISO 8015  
ISO 2768 - m H  
< 6 mm: ±0.2 mm

Workpiece touch probe	TS 220	TS 230
<b>Probe accuracy</b>	≤ ± 5 µm when using a standard stylus	
<b>Probe repeatability</b> Repeated probing from one direction	2 σ ≤ 1 µm at a probing velocity of 1 m/min <i>Typical values:</i> 2 σ ≤ 1 µm at a probing velocity of 3 m/min 2 σ ≤ 4 µm at a probing velocity of 5 m/min	
<b>Deflection of probe contact</b>	≤ 5 mm in all directions (with stylus length L = 40 mm)	
<b>Deflection force</b>	Axial: Approx. 8 N Radial: approx. 1 N	
<b>Probe velocity</b>	≤ 5 m/min	
<b>Protection</b> EN 60529	IP 55	
<b>Operating temperature</b>	10 °C to 40 °C	
<b>Storage temperature</b>	-20 °C to +70 °C	
<b>Weight</b> without taper shank	Approx. 0.7 kg	
<b>Taper shank*</b>	<ul style="list-style-type: none"> <li>• With taper shank* (overview on page 18)</li> <li>• W/o taper shank (connecting thread M30 x 0.5)</li> </ul>	
<b>Power supply</b> Without load	5 V ± 5% DC / ≤ 100 mA	10 V to 30 V DC / ≤ 100 mA
<b>Output signals</b>	One square-wave signal and its inverted signal Trigger signals S and $\bar{S}$	
<b>Signal levels</b>	<b>TTL</b> $U_H \geq 2.5 \text{ V}$ at $-I_H \leq 20 \text{ mA}$ $U_L \leq 0.5 \text{ V}$ with $I_L \leq 20 \text{ mA}$ At 5 V rated voltage	<b>HTL</b> $U_H \geq 20 \text{ V}$ at $-I_H \leq 20 \text{ mA}$ $U_L \leq 2.8 \text{ V}$ at $I_L \leq 20 \text{ mA}$ at 24 V rated voltage
<b>Electrical connection</b>	Spiral cable, 1.5 m with 6-pin quick disconnect	Spiral cable 1.5 m with M23 connector (male) 7-pin M23

\* Please select when ordering



# TS 249

## Workpiece Touch Probe for Grinding Machines and Lathes

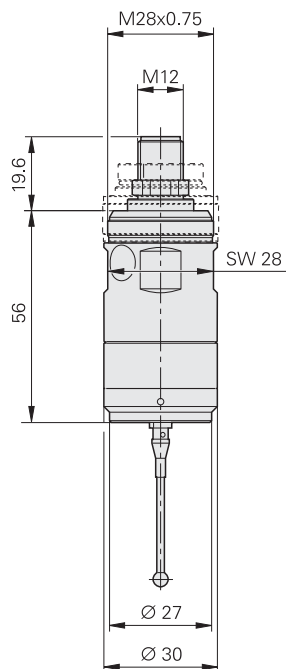

**Axial flange socket**

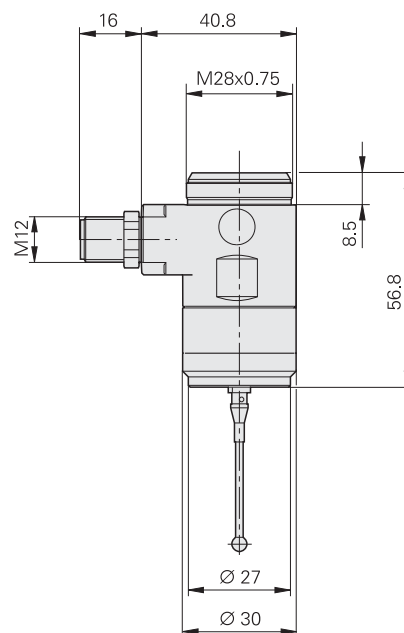

**Radial flange socket**

mm  
  
Tolerancing ISO 8015  
ISO 2768 - m H  
< 6 mm: ±0.2 mm

<b>Workpiece touch probe</b>	<b>TS 249</b>
<b>Probe accuracy</b>	$\leq \pm 5 \mu\text{m}$ when using a standard stylus
<b>Probe repeatability</b> Repeated probing from one direction	$2 \sigma \leq 1 \mu\text{m}$ at a probing velocity of 1 m/min <i>Typical values:</i> $2 \sigma \leq 1 \mu\text{m}$ at a probing velocity of 3 m/min $2 \sigma \leq 4 \mu\text{m}$ at a probing velocity of 5 m/min
<b>Deflection of probe contact</b>	$\leq 5 \text{ mm}$ in all directions (with stylus length $L = 40 \text{ mm}$ )
<b>Deflection force</b>	Axial: Approx. 7 N Radial: Approx. 0.7 to 1.3 N
<b>Probe velocity</b>	$\leq 5 \text{ m/min}$
<b>Protection EN 60529</b>	IP 67
<b>Operating temperature</b>	10 °C to 40 °C
<b>Storage temperature</b>	-20 °C to +70 °C
<b>Weight</b>	Approx. 0.15 kg
<b>Fastening*</b>	<ul style="list-style-type: none"> <li>• Via M28x0.75 external thread</li> <li>• Via coupling joint with M22x1 external thread</li> </ul>
<b>Power supply</b> Without load	15 V to 30 V DC / $\leq 100 \text{ mA}$
<b>Output signals</b>	One square-wave signal and its inverted signal Trigger signals S and $\bar{S}$ Additional floating switching outputs
<b>Signal levels</b>	<b>HTL</b> $U_H \geq 20 \text{ V}$ at $-I_H \leq 20 \text{ mA}$ $U_L \leq 2.8 \text{ V}$ at $I_L \leq 20 \text{ mA}$ at 24 V rated voltage
<b>Electrical connection*</b>	M12 flange socket, 8-pin; axial or radial
<b>Cable length</b>	$\leq 25 \text{ m}$

\* Please select when ordering

# Selection Guide

Tool measurement on the machine shortens non-productive times, increases machining accuracy and reduces scrapping and reworking of machined parts. With the tactile TT touch probes and the contact-free TL laser systems, HEIDENHAIN offers two completely different possibilities for tool measurement.

With their rugged design and high degree of protection, these tool touch probes can be installed directly within the machine tool's work envelope.

## TT touch probes

The TT 140 and TT 449 tool touch probes are touch trigger probes for the measurement and inspection of tools. The TT 140 features signal transmission by cable, while the TT 449 communicates wirelessly over an infrared beam with the SE 642 transmitter/receiver unit.

The disk-shaped probe contact of the TT is deflected during physical probing of a tool. At that moment the TT generates a trigger signal that is transmitted to the control, where it is processed further. The trigger signal is generated through a wear-free optical switch that ensures high reliability.

The probe contact is easy to exchange. The connection pin to the touch probe's contact plate features a rated break point. This protects the touch probe from physical damage due to operator error.

## TL laser systems

The TL Micro and TL Nano laser systems can measure tools at the rated speed without making contact. With the aid of the included measuring cycles you can measure tool lengths and diameters, inspect the form of the individual teeth and check for tool wear or breakage. The control automatically saves the results of measurement in the tool table.

The measurement is very fast and uncomplicated. Under program control, the NC control positions the tool and starts the measuring cycle. This is always possible: before machining, between two machining steps, or after machining is done.

The axially focused laser beam measures tools as small as 0.03 mm in diameter at a repeatability of up to  $\pm 0.2 \mu\text{m}$ .

	TT touch probes		TL Laser System			
<b>Probing method</b>	Physical probing		Non-contacting by laser beam			
<b>Probing directions</b>	3-dimensional: $\pm X, \pm Y, +Z$		2-dimensional: $\pm X$ (or $\pm Y$ ), $+Z$			
<b>Probing forces</b>	Axial: 8 N, radial 1 N		No forces, operates without contact			
<b>Tool materials</b>	Breakage-prone teeth are at risk		Any			
<b>Sensitivity to unclean tools</b>	Very small		High (tool must be cleaned with blown air before measurement)			
<b>Possible measuring cycles</b>	Length, radius, breakage, individual teeth		Length, radius, breakage, individual teeth, tooth geometry (also for combined contours)			
<b>Installation effort</b>	Simple connection to NC control		PLC adaptation in the NC control necessary (6 outputs, 3 inputs), compressed air connection			
<b>Signal transmission</b>	Cables	Infrared to SE 642	Cables			
<b>Repeatability</b>	$2 \sigma \leq 1 \mu\text{m}$		$2 \sigma \leq 0.2 \mu\text{m}$		$2 \sigma \leq 1 \mu\text{m}$	
<b>Min. tool diameter</b>	3 mm <sup>1)</sup>		0.03 mm		0.1 mm	
<b>Max. tool diameter</b>	Unlimited		37 mm <sup>2)</sup>	30 mm <sup>2)</sup>	80 mm <sup>2)</sup>	180 mm <sup>2)</sup>
<b>Type</b>	<b>TT 140</b>	<b>TT 449</b>	<b>TL Nano</b>	<b>TL Micro 150</b>	<b>TL Micro 200</b>	<b>TL Micro 300</b>

<sup>1)</sup> Probing force must not result in tool damage

<sup>2)</sup> With centered measurement

## Contents

<b>TT Touch Probe</b>	<b>General Information</b>	<b>36</b>	
	<b>Principle of Function</b>	<b>37</b>	
	<b>Mounting</b>	<b>38</b>	
	<b>Probing</b>	<b>39</b>	
	<b>Specifications</b>	TT 140	<b>40</b>
		TT 449	<b>42</b>
<b>TL Laser System</b>	<b>General Information</b>	<b>44</b>	
	<b>Components</b>	<b>45</b>	
	<b>Mounting</b>	<b>46</b>	
	<b>Probing</b>	<b>48</b>	
	<b>Specifications</b>	TL Nano	<b>50</b>
		TL Micro	<b>52</b>
DA 301 TL		<b>54</b>	



# TT Touch Probes for Tool Measurement

Together with the measuring cycles of the CNC control, the TT tool touch probes enable the TNC to measure tools automatically while they are in the machine spindle. The control saves the values measured for tool length and radius in the central tool file. By inspecting the tool during machining you can quickly and directly measure wear or breakage to prevent scrap or rework. If the measured deviations lie outside the tolerances, or if the monitored life of the tool is exceeded, the control can lock the tool or automatically insert a replacement tool.

With the **TT 449**, all signals are transmitted to the control via infrared beam.

Advantages:

- Greatly increased mobility
- Fast installation at any location
- Use also on rotary and tilting axes

**Your benefit:** With the TT 140 or TT 449 tool touch probe you can have your CNC machine operate unattended without losing accuracy or increasing scrap rates.



# Principle of Function

## Sensor

Touch probes from HEIDENHAIN operate with an optical switch as sensor. A lens system collimates the light generated from an LED and focuses it onto a differential photocell. When the probe contact is deflected, the differential photocell produces a trigger signal. The probe contact of the TT is rigidly connected to a plate integrated in the probe housing on a three-point bearing. The three-point bearing ensures the physically ideal rest position.

With its contact-free optical switch, the sensor operates without wear to guarantee the high long-term stability of HEIDENHAIN touch probes.

## Repeatability

For workpiece measurement, the reproducibility of the probing process is of major importance. The probe repeatability specifies the error resulting from repeatedly probing a tool from one direction at 20 °C ambient temperature.

The probing accuracy of a touch probe is measured at HEIDENHAIN on precision measuring machines.

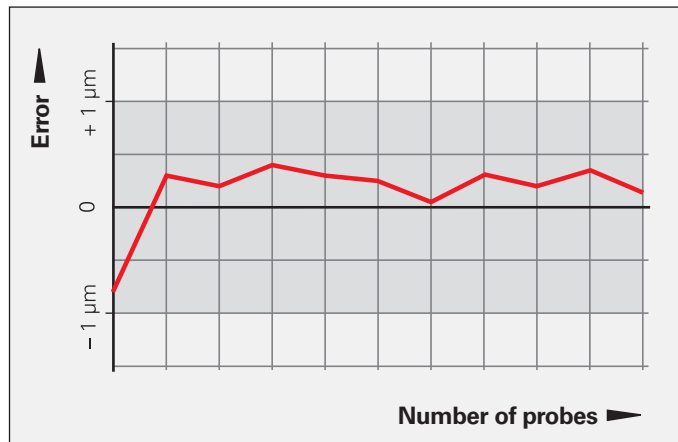
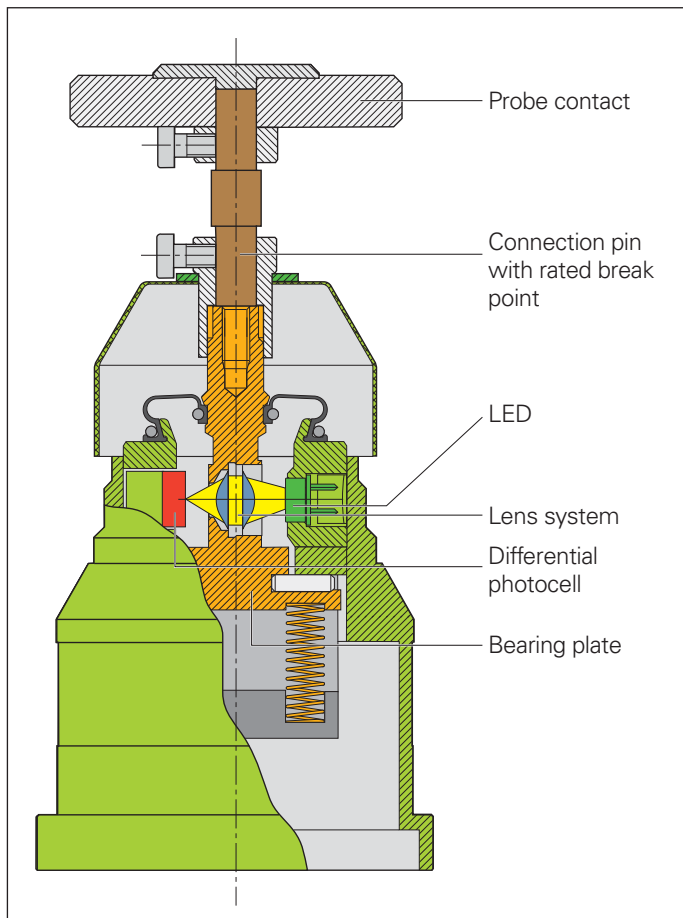

Typical repeatability curve of a touch probe: results of repeated probing from one direction.

# Mounting

The tool touch probes feature IP 67 protection and can therefore be fixed within the working space of the machine. The TT is mounted with two fixing clamps or on an accessory space-saving mounting base.

The TT with 40-mm probe contact should be operated vertically to ensure reliable probing and optimum protection against contamination. Like the cuboid probe contact, the 25 mm diameter SC02 probe contact can also be operated when mounted in a horizontal position.

During workpiece machining, the TT must be switched off to ensure that the vibrations that accompany normal machining do not trigger a probe signal and cause an interruption. The working space of the machine tool should be limited in order to prevent collision with the tool touch probe during machining.

Accessory:

**Mounting base** for TT  
For fastening with a central screw  
ID 332400-01

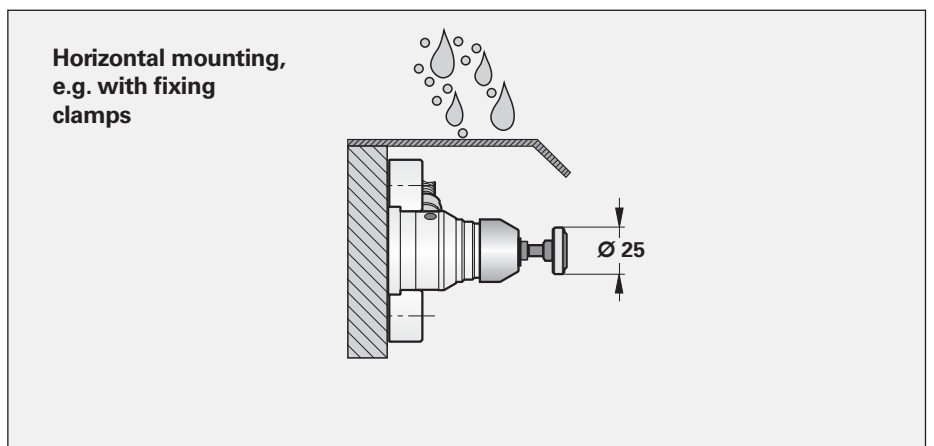
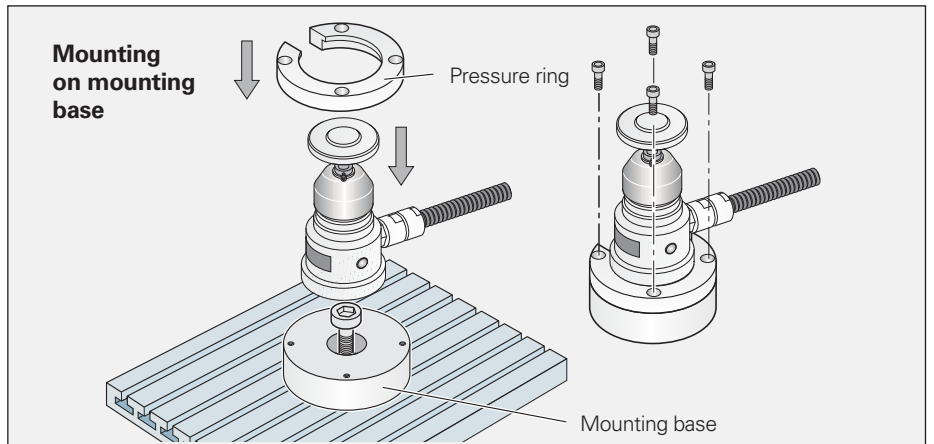
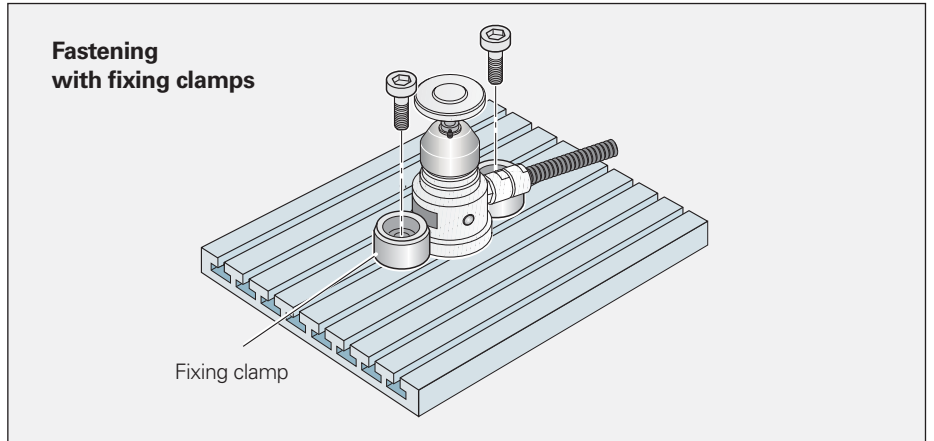

## Power supply and signal transmission

For the TT 140 touch probe, both the power supply and the trigger signal are conducted over the touch probe's cable. The TT 449 transmits the trigger signal by infrared beam to the SE 642 transceiver (see pages 14/15).

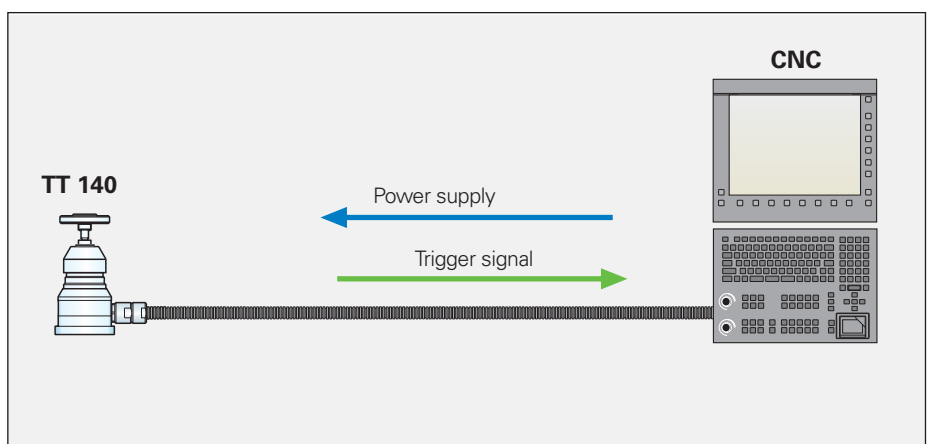

# Probing

The hardened probe contact of the TT tool touch probe permits direct probing of the tool as it rotates opposite to the cutting direction. Speeds of up to  $1000 \text{ min}^{-1}$  are permissible depending on the tool diameter. The probe contact is quickly exchanged: it is simply screwed onto the touch probe through a fit.

The maximum permissible deflection of the probe contact is 5 mm in any direction. The machine must stop moving within this distance.

The probe contact of the TT features a **rated break point** in order to protect the touch probe from physical damage due to operator error. The rated break point is effective in all probing directions. A rubber sleeve offers protection from splinters. A defective connection pin can easily be replaced without requiring readjustment of the TT.

## Optical deflection display

Two LEDs on the TT 140 additionally indicate deflection of the probe contact. On the TT 449, the condition of the touch probes is visible through LEDs on the SE 642 transmitter/receiver unit. This is especially useful for testing correct operation. You can see at a glance whether the TT is currently deflected.

## Probe contacts

To probe **milling cutters**, the tool touch probes are equipped with a disk-shaped probe contact with 40 mm diameter (example). A disk-shaped probe contact with a 25 mm diameter is available as an accessory. Because of its small weight, it is particularly recommended for horizontal mounting of the TT.

The TT tool touch probe can also be used to calibrate **lathe tools** (example). The flat surfaces of a cuboid probe contact (available as an accessory) are contacted by the edges of the lathe tool. This makes it possible to regularly inspect tools in NC controlled lathes for breakage and wear in order to ensure process reliability.

The probe contacts can be ordered separately for replacement. They can be easily replaced, without requiring readjustment of the TT.

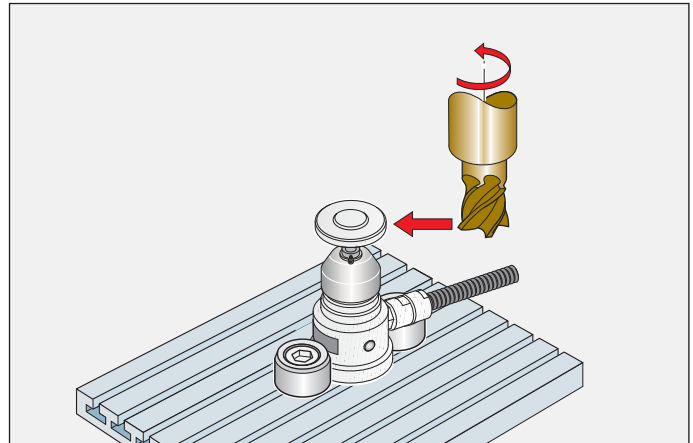

Connection pin to the contact plate (shown without rubber sleeve)

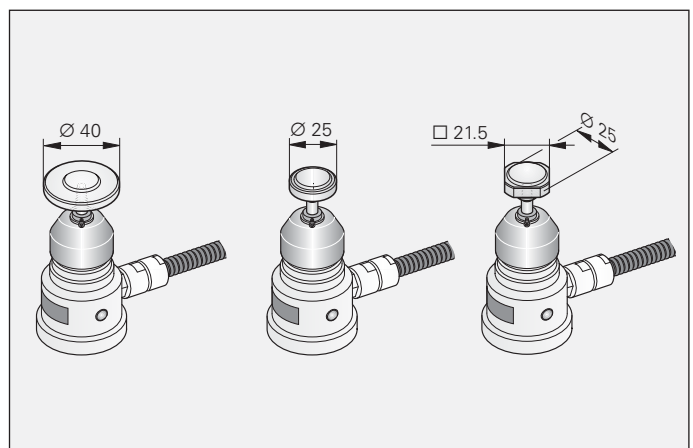

Accessories:

**Probe contact SC02**  $\varnothing 25 \text{ mm}$   
ID 574 752-01

**Probe contact SC01**  $\varnothing 40 \text{ mm}$   
ID 527 801-01

**Probe contact cuboid**  
ID 676 497-01



# TT 140

## Tool Touch Probe with Cable Connection



Mounting with fixing clamps included in delivery



Fastening with mounting base accessory

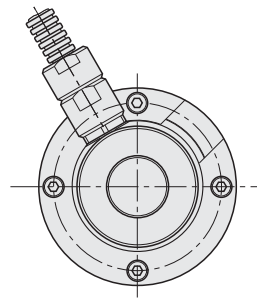
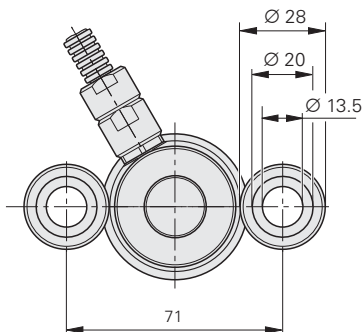
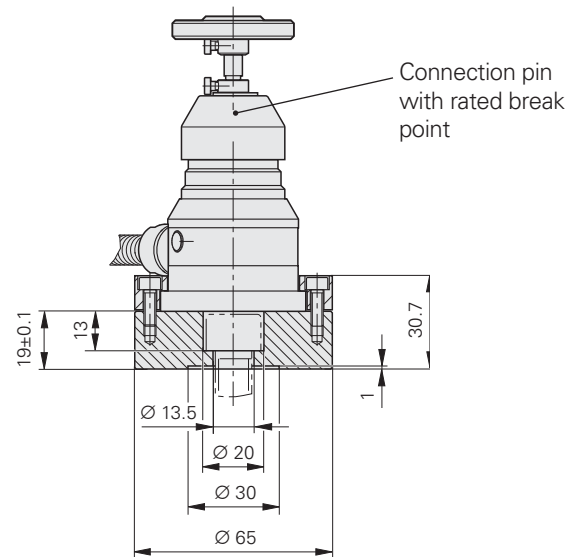
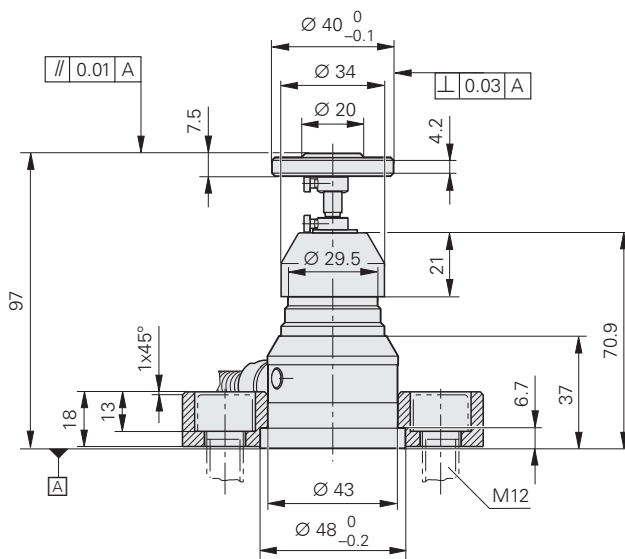

mm  
  
 Tolerancing ISO 8015  
 ISO 2768 - m H  
 < 6 mm: ±0.2 mm

Specifications	TT 140
<b>Probe accuracy</b>	≤ 15 µm
<b>Probe repeatability</b> Repeated probing from one direction	2 σ ≤ 1 µm at a probing velocity of 1 m/min <i>Typical values:</i> 2 σ ≤ 1 µm at a probing velocity of 3 m/min 2 σ ≤ 4 µm at a probing velocity of 5 m/min
<b>Deflection of the probe contact</b>	≤ 5 mm in all directions
<b>Deflection force</b>	Axial: approx. 8 N Radial: approx. 1 N
<b>Probe contact*</b>	Ø 40 mm or Ø 25 mm
<b>Probe velocity</b>	≤ 5 m/min
<b>Protection EN 60529</b>	IP 67
<b>Operating temperature</b>	10 °C to 40 °C
<b>Storage temperature</b>	-20 °C to +70 °C
<b>Weight</b>	Approx. 1.0 kg
<b>Mounting on the machine table</b>	Fastening by fixing clamps (included in delivery) Fastening with mounting base (accessory)
<b>Power supply</b> Without load	10 V to 30 V DC / ≤ 100 mA
<b>Output signals</b>	One HTL square-wave signal and its inverted signal Trigger signals S and $\bar{S}$
<b>Signal levels</b>	<b>HTL</b> $U_H \geq 20 \text{ V}$ at $-I_H \leq 20 \text{ mA}$ $U_L \leq 2.8 \text{ V}$ at $I_L \leq 20 \text{ mA}$ at 24 V rated voltage
<b>Electrical connection</b>	Cable, 3 m, in metal armor with M23 connector (male), 7-pin
<b>Cable length</b>	≤ 50 m

\* Please select when ordering

# TT 449

## Tool Touch Probe with Infrared Transmission



Mounting with fixing clamps included in delivery



Fastening with mounting base accessory

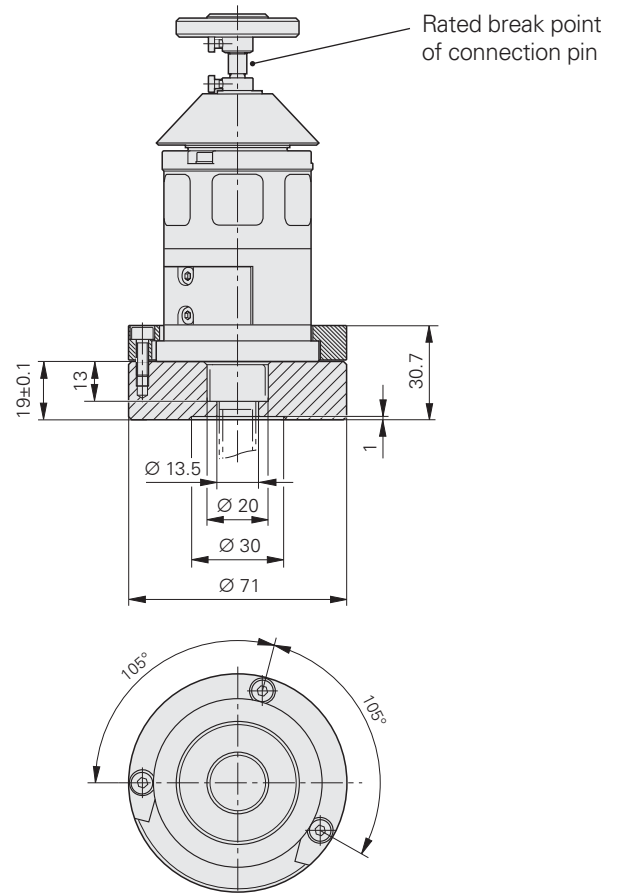
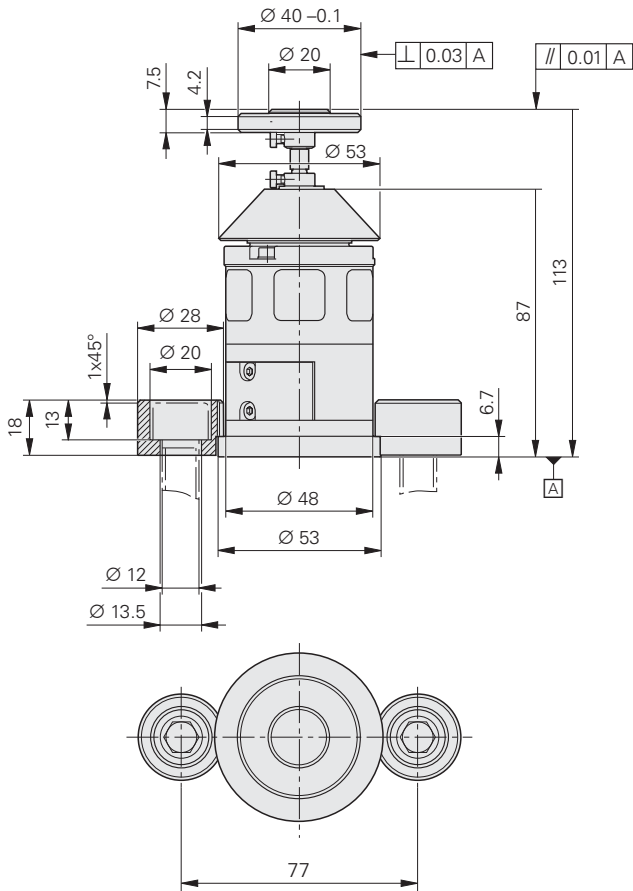

mm  
 Tolerancing ISO 8015  
 ISO 2768 - m H  
 < 6 mm:  $\pm 0.2$  mm

Specifications	TT 449
<b>Probe accuracy</b>	≤ 15 µm
<b>Probe repeatability</b> Repeated probing from one direction	2 σ ≤ 1 µm at a probing velocity of 1 m/min <i>Typical values:</i> 2 σ ≤ 1 µm at a probing velocity of 3 m/min 2 σ ≤ 4 µm at a probing velocity of 5 m/min
<b>Deflection of the probe contact</b>	≤ 5 mm in all directions
<b>Deflection force</b>	<i>Axial:</i> approx. 8 N <i>Radial:</i> approx. 1 N
<b>Probe contact*</b>	Ø 40 mm or Ø 25 mm
<b>Probe velocity</b>	≤ 5 m/min
<b>Protection EN 60529</b>	IP 67
<b>Operating temperature</b>	10 °C to 40 °C
<b>Storage temperature</b>	-20 °C to +70 °C
<b>Weight</b>	Approx. 0.6 kg
<b>Mounting on the machine table</b>	<ul style="list-style-type: none"> <li>• Fastening by fixing clamps (included in delivery)</li> <li>• Fastening with mounting base (accessory)</li> </ul>
<b>Signal transmission</b>	Infrared transmission with 360° range
<b>Transmission angle of infrared signal</b>	0°
<b>Transceiver unit</b>	SE 642
<b>TT switch-on/off</b>	Infrared signal from SE 642
<b>Power supply</b>	2 batteries (rechargeable or nonrechargeable), size <sup>2</sup> / <sub>3</sub> AA or size N <sup>1)</sup> each 1 V to 4 V
Operating time	Continuous duty typically 200 hours with lithium batteries 3.6V/1 200 mAh (included in delivery)

\* Please select when ordering

<sup>1)</sup> Via adapter, included in delivery

# TL Laser Systems for Tool Measurement

Tool monitoring with a TL laser system is a very flexible solution. The contact-free optical measurement enables you to check even the smallest tools rapidly, reliably and without collision. Even the most sensitive tools are completely secure from damage.

The precise determination of the length and radius at the rated shaft speed ensures your high quality of production. At the same time this integrated tool setting with automatic updating of tool data eliminates the need for separate tool setting, reducing costs and non-productive times.

Tool monitoring occurs at the rated shaft speed in the real clamping system, and as such under real operating conditions. Errors on the tool, spindle and holder can be immediately detected and corrected. Every single tooth is measured at the highest speed. Even the geometry of special tools can automatically be checked on the machine for deviations.

The continual process inspection with monitoring of the tool data detects wear, tooth breakage and tool breakage before damage occurs. This ensures consistent production quality, avoids subsequent damage, and reduces the cost of scrapped or reworked parts. The measuring cycles operate automatically, ensuring optimum monitoring even during unattended operation.

The TL laser systems guarantee reliable tool monitoring, high measuring accuracy, and precise inspection for wear and tear. They offer the following benefits:

- Reduced non-productive times
- Unattended operation
- Less scrap
- Increased productivity
- Consistently high quality of production

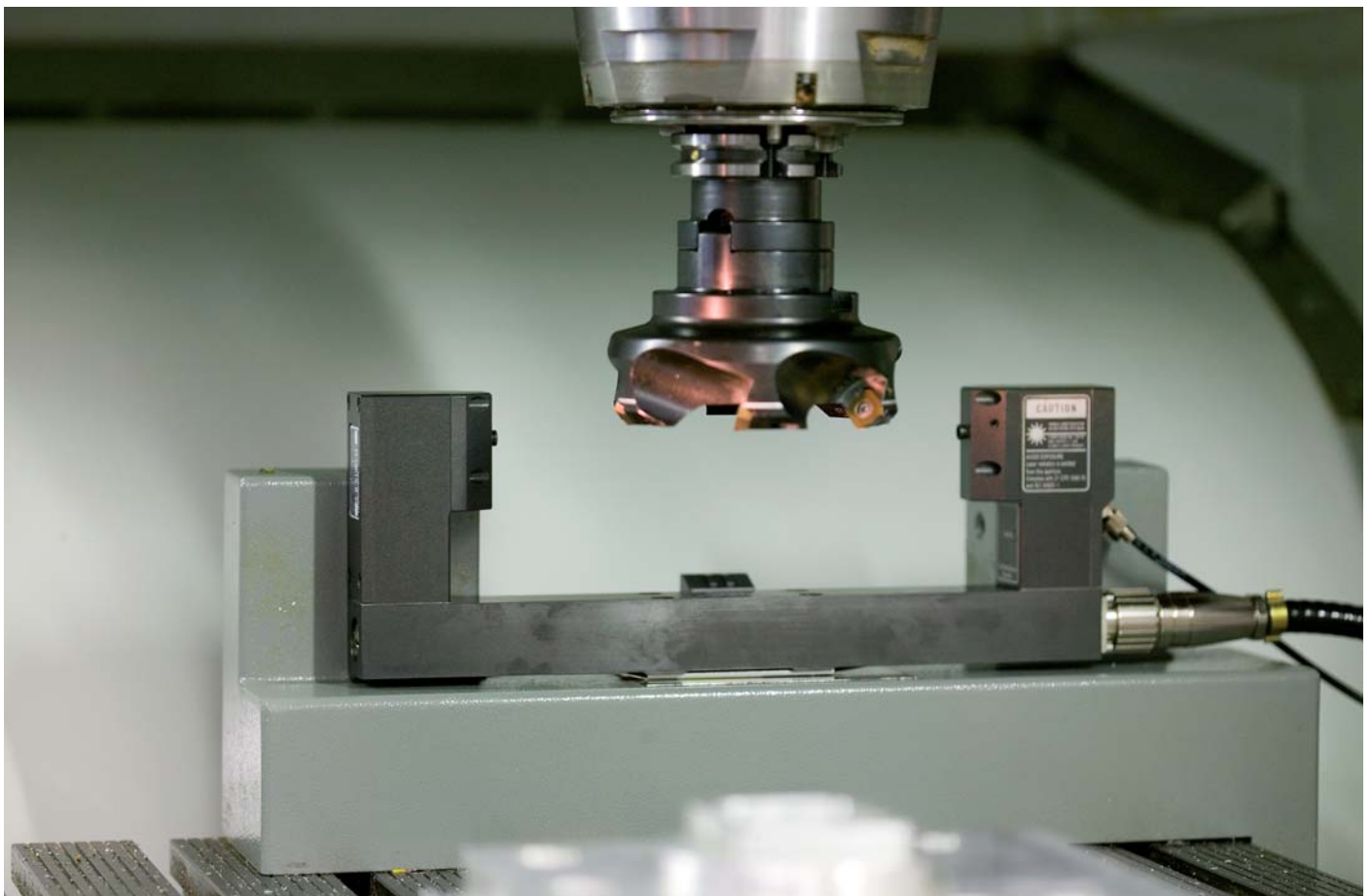

# Components

## TL laser systems

The laser systems are available in different versions for various maximum tool diameters:

- TL Nano
- TL Micro 150
- TL Micro 200
- TL Micro 300

The devices have an integral blowing unit to remove chips and coolant from the tool with a blast of compressed air.

The TL laser systems are optimized to the spindle shaft speed of NC machines for standard spindles and for HSC spindles (over  $30\,000\text{ min}^{-1}$ ).

The TL Micro systems are available as versions with cable exits and compressed air connections on the bottom or on the side.

## Measuring cycles

The NC control uses measuring cycles to process the output signal of the laser systems and performs the necessary calculations. Measuring cycles for the TNC 426/430 and iTNC 530 controls from HEIDENHAIN are included with the TL laser systems. The measuring cycles contain functions for

- Tool setting with automatic transmission of the data to the tool table
- Inspection of wear and tear with or without correction of the tool data
- Identification with or without correction of the tool data

## Compressed air unit

A **DA 301 TL** compressed air unit, specifically designed for these requirements, is necessary for operation of the TL laser systems. It consists of three filter stages (pre-filter, fine filter and activated carbon filter), an automatic condensation trap, and a pressure regulator with pressure gauge, as well as three control valves. They activate the sealing unit of the laser optics, supply the laser system with sealing air, and blow the tool clean. The PLC program triggers the control valves.

## Accessories

A comprehensive series of accessories simplifies the mounting and maintenance of the TL laser systems.



# Mounting

## Mounting attitude

The TL laser systems fulfill the requirements for IP 68 and can therefore be fixed directly in the machine's working space. For smooth operation, even with coolant and chips, the transmitter and receiver feature a pneumatically activated sealing system. The additional introduction of sealing air provides a very high degree of protection against contamination.

The TL laser systems can be mounted in both upright and resting positions on or next to the machine table. They must be mounted in a stable enough manner to guarantee high repeatability. The cutting edge should rotate in the appropriate direction for avoiding bothersome reflections and refractions during measurement by the laser beam.

The working space of the machine tool should be limited in order to prevent collision with the laser system during machining.

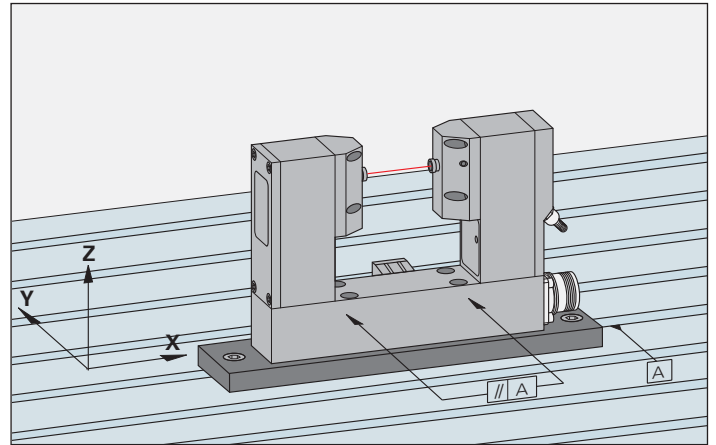

## Adjusting the TL

In order to achieve the best possible repeatability, the laser system must be mounted exactly parallel to two NC axes. For upright mounting on the machine table, the horizontal alignment is ensured by the mounting surface. The mounting tolerances are included in the dimension drawings. Deviations in the parallelism are particularly noticeable as linear errors when measuring the length of very different tool diameters. It is therefore recommended that the length of eccentric tools (e.g. end mills, face-milling cutters) be measured on the outside radius outside of the tool axis.

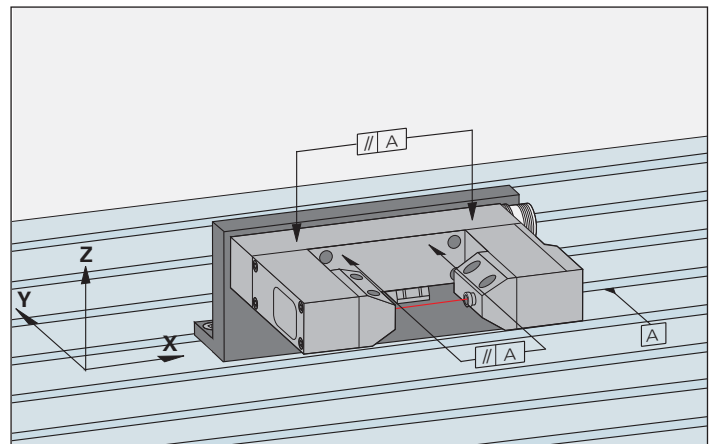

## Mounting accessory for TL Micro

The mounting base makes it very easy to install a TL Micro laser system on the machine table. Two stop pins on the base permit you to remove and reinstall the laser system without having to readjust it.

Accessory:  
Mounting plate for TL Micro  
ID 560028-01

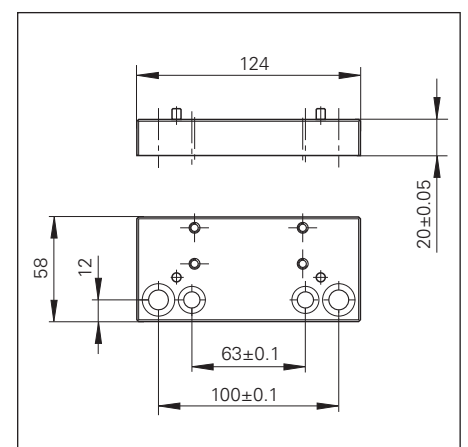

# Contamination Protection

The application of laser systems directly on machine tools requires effective measures to protect the sensitive optical system of the laser light barrier.

## Mechanical protection

The optics of the laser systems are perfectly sealed against coolant and chips by contamination shutters with an integrated mechanical seal system. The seal enables the optical system only for the duration of the measurement. The seal is actuated pneumatically by the DA 301 TL compressed air unit.

## Sealing air

The transmitter and receiver of the laser light barrier are protected by very clean sealing air from the DA 301 TL compressed air unit. It prevents contamination of the optical system by coolant spray.

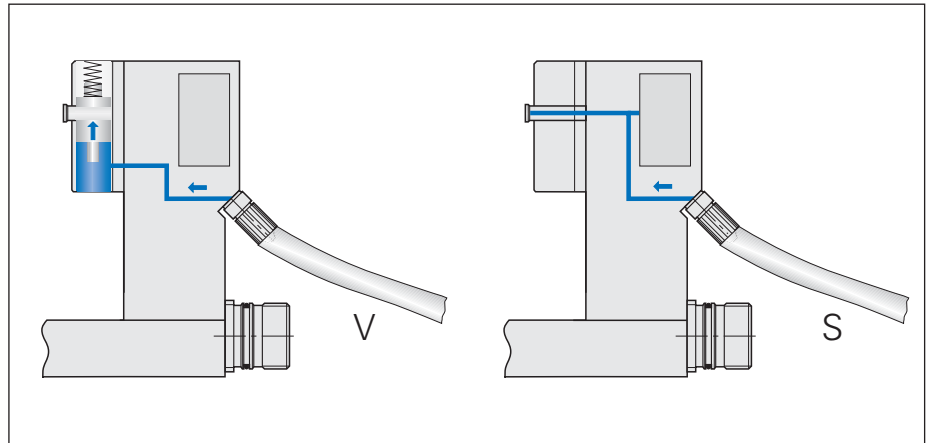

Pneumatic systems in the TL with connections for sealing air (S) and seal control (V)

## Accessories

### Maintenance kit for protective shutter

ID 560 034-01

A maintenance kit consisting of the following items is offered for cleaning the contamination shutters of the laser optics.

- Gasket set
- Sintered sleeves
- Filler plugs
- O-rings
- M3x8 hexagon socket screws
- Special lubricant
- Operating instructions

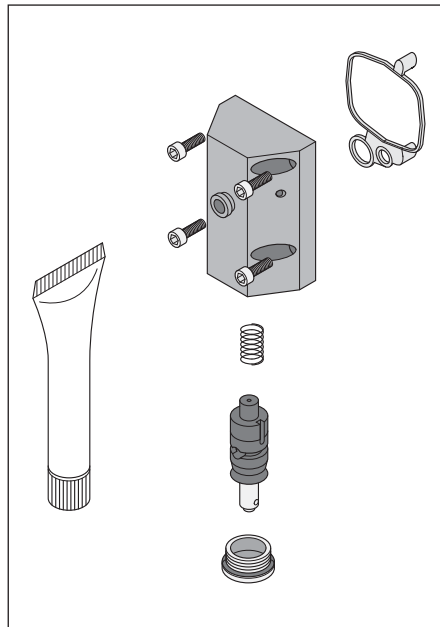

### Replacement filters

ID 560 036-01

Complete filter set for the DA 301 TL consisting of prefilter, fine filter, and activated carbon filter.

### Protective springs

ID 560 037-01

Set of spiral springs for protecting the compressed air tubing in the machine envelope  
Set: 2 x Ø 6 mm, 1 x Ø 4 mm;  
Length each: 1 m

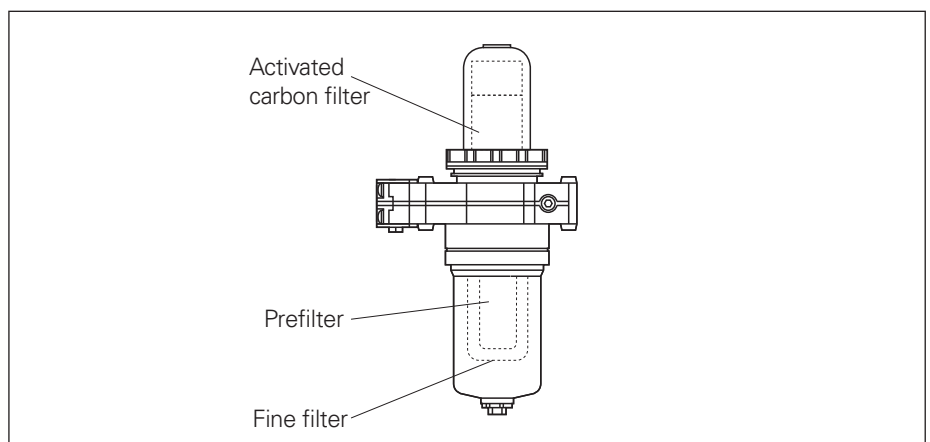



# Probing

The TL laser systems operate as high-precision light barriers without any contact. A laser light source (protection class 2 as per IEC 825) emits a laser beam. The opposing receiver unit detects the laser beam and so captures every interruption. For any change in status—such as when a tool interrupts the laser beam or is removed again—the integral electronics generate a trigger pulse for a defined duration. This dynamic signal DYN is transmitted to the NC control, where it is used for capturing the position value. In addition, the laser system outputs the static signal STA for the duration that the laser beam is interrupted.

## Calibrating

Before measurement with the TL laser system can be started, the system must be calibrated, meaning that the exact position of the trigger points relative to the machine coordinate system must be determined. A reference tool, available as an accessory, is used for this purpose. It has a characteristic shape for calibration, with a cylindrical dowel pin and a stepped inspection diameter for measurement in the positive and negative Z axis directions (for determining the exact position of the center of the laser beam in Z). The reference tool is clamped into the tool holder, and its length, diameter and height are measured very exactly. A cylindrical dowel pin suffices for simple applications. The best possible runout is to be ensured for the calibration measurement.

Accessory:  
Reference tool  
ID 560032-01

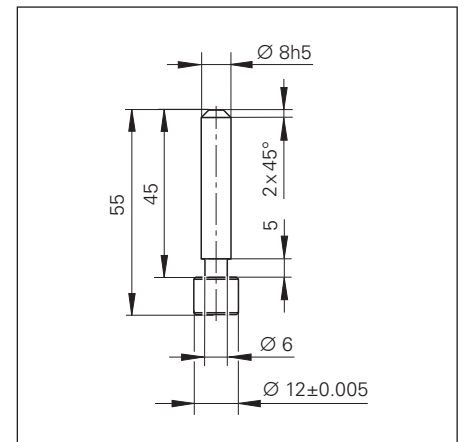
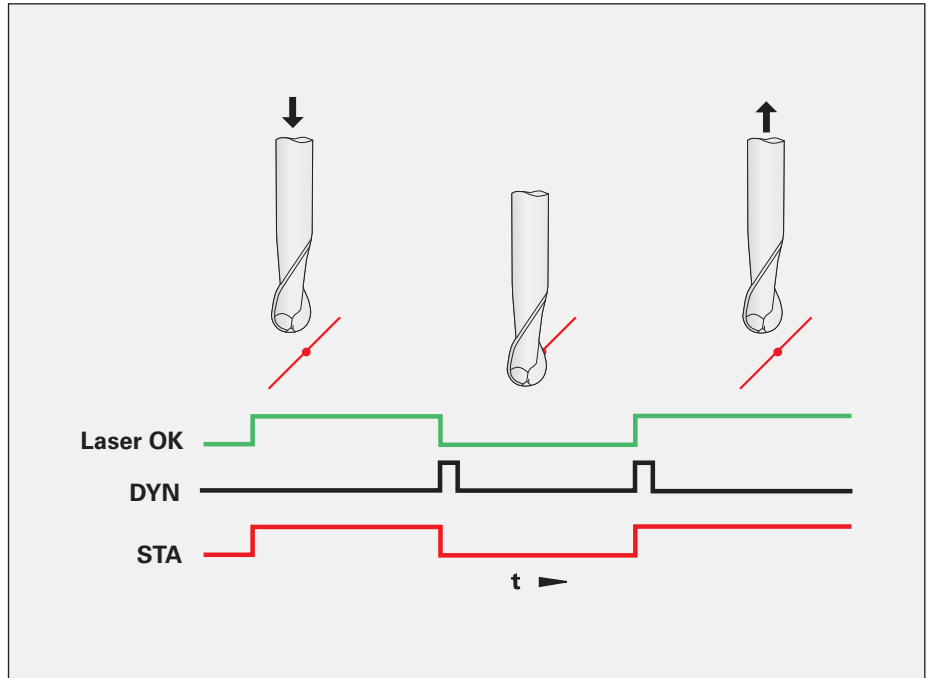

## Probing strategies

The mechanical transfer elements influence the accuracy of the measurement. The measured value can be captured either when the tool is moved into the laser beam ("pushing measurement") or when it is removed ("pulling measurement"). The pulling measurement ensures a high degree of protection against the influence of coolant and swarf, while the pushing measurement is the better method for engraving bits and tools with very small shaft diameters.

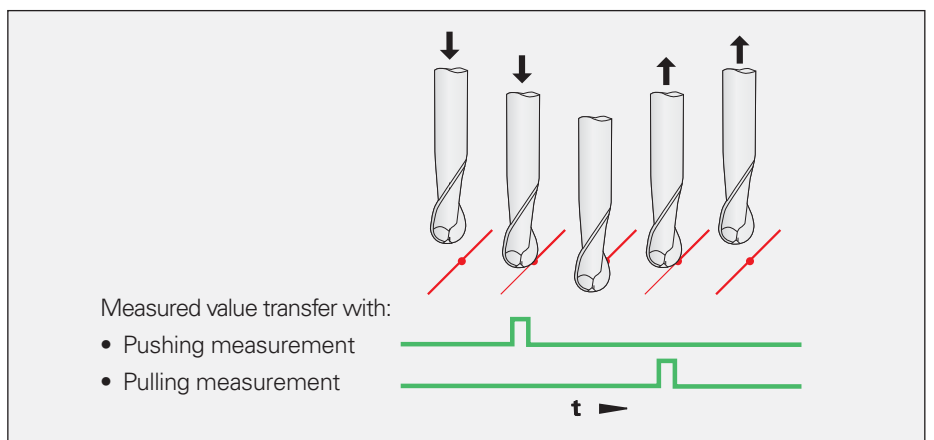





### Operating modes

The operating mode of the laser system is defined over the receiver-enabling inputs 1 and 2 (ENABLE 1/ENABLE 2). The measuring signals automatically put the receiver in the appropriate operating mode.

During **inspection of individual teeth**, each available tooth generates an output pulse of defined duration. The pulse length and the number of teeth define the basic speed. In the event of error—a missing tooth or a tolerance error—the dynamic output signal (DYN) stays at low level for max. 100 seconds.

In the **measuring** mode, every change of light causes an output signal DYN with a defined duration of 20 ms. The positive edge is evaluated. The device is switched between “pushing” and “pulling” measurement over the receiver-enabling input 2 (ENABLE 2).

Operating mode	ENABLE 1	ENABLE 2	Function
0	0	0	Inspection of individual teeth Base speed 3750 min <sup>-1</sup> 
1	0	1	Pushing measurement Base speed ≥ 0 min <sup>-1</sup> 
2	1	0	<i>On version for standard machine*</i> Pulling measurement Base speed 600 to 3000 min <sup>-1</sup> 
			<i>On version for HSC machines*</i> Inspection of individual teeth Base speed 42000 min <sup>-1</sup> 
3	1	1	Pulling measurement Base speed ≥ 3000 min <sup>-1</sup> 









\* Please select when ordering

### Optical status indicator

LEDs on the receiver side of the laser system make a rapid diagnosis of the status possible. In this way, the operator sees at a glance whether the laser beam path is OK, whether a dynamic trigger signal is being output, and which operating mode of the laser system is active.

### Probing used tools

The optically scanning laser system can of course not distinguish between the actual tool to be measured and any attached chips, coolant coating or falling drops of coolant. In order to avoid faulty measurements, the tool should therefore be cleaned before measuring. This can be done by spinning off any particles at a high rotational velocity or by blowing them off with air. The TL laser systems feature an integral blowing feature for this, which can be used to clean the tool before and during a measuring cycle.

Optical status indicator	LED	Function
Laser ON		Input for enabling transmission
Alignment		Laser adjustment OK (signal > 95 %)
Laser OK		Laser output OK (signal > 75 %)
Output		DYN output (signal > 50 %)
Mode		Operating mode 0
		Operating mode 1
		Operating mode 2
		Operating mode 3

# TL Nano

## Laser System for Tool Measurement



mm  
  
 Tolerancing ISO 8015  
 ISO 2768 - m H  
 < 6 mm: ±0.2 mm

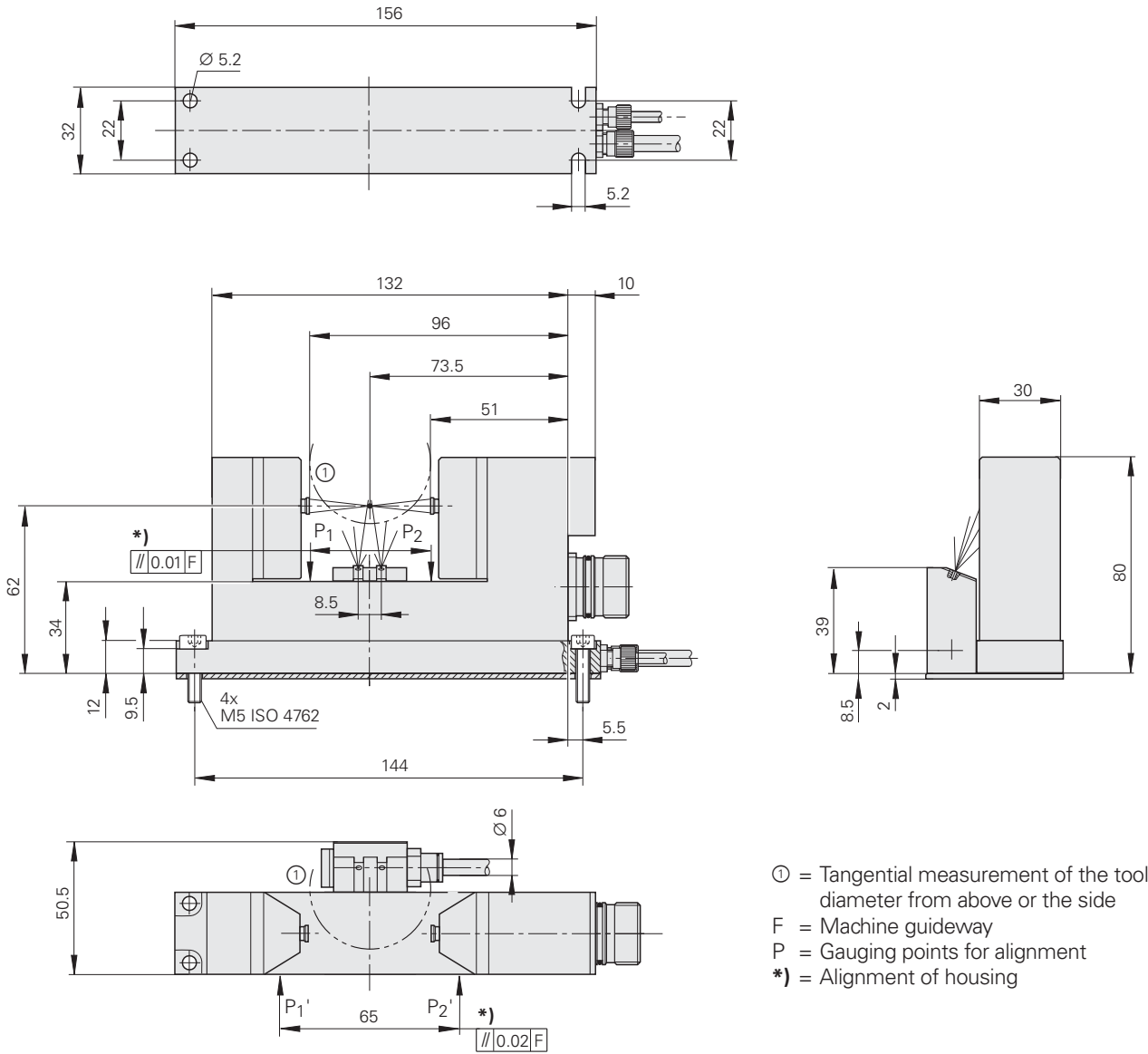

- ① = Tangential measurement of the tool diameter from above or the side
- F = Machine guideway
- P = Gauging points for alignment
- \*) = Alignment of housing

Specifications	TL Nano
<b>Tool diameter</b> Central measurement Tangential measurement	0.03 to 37 mm 0.03 to 44 mm
<b>Repeatability</b>	± 0.2 µm
<b>Spindle speed*</b>	Optimized for individual tooth measurement on standard or HSC spindles (> 30000 min <sup>-1</sup> )
<b>Lasers</b>	Visible red-light laser with beam focused at center of system
Wavelength/Power	630 to 700 nm / < 1 mW
Protection class IEC 825	2
<b>Input signals</b>	Square-wave signals 24 V DC <ul style="list-style-type: none"> <li>• Enable transmitter                   ENABLE 0</li> <li>• Enable 1 receiver                    ENABLE 1</li> <li>• Enable 2 receiver                    ENABLE 2</li> </ul>
<b>Output signals</b>	Square-wave signals 24 V DC <ul style="list-style-type: none"> <li>• Dynamic triggering signal         DYN</li> <li>• Static triggering signal            STA</li> <li>• Proper laser function              LASER OK</li> </ul>
<b>Power supply</b>	24 V DC / 160 mA
<b>Electrical connection</b>	M23 coupling (male), 12-pin, at side
<b>Mounting</b>	Within the machine work envelope
<b>Protection EN 60529</b>	IP 68 (when connected, with sealing air)
<b>Tool cleaning</b>	Blower
<b>Operating temperature</b> <b>Storage temperature</b>	10 °C to 40 °C 0 °C to 50 °C
<b>Weight</b>	Approx. 0.70 kg (including blower)

\* Please select when ordering

# TL Micro

## Laser System for Tool Measurement

mm  
  
 Tolerancing ISO 8015  
 ISO 2768 - m H  
 < 6 mm: ±0.2 mm

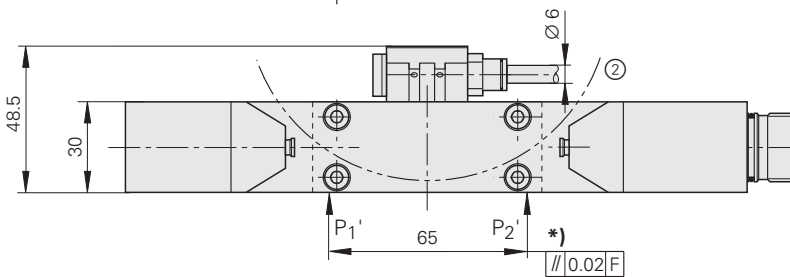
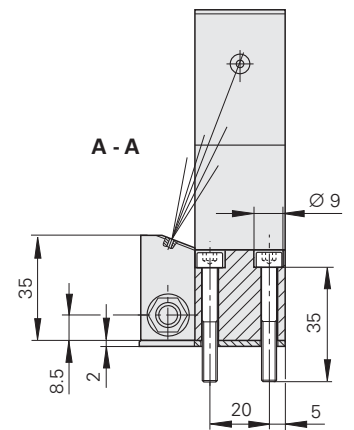
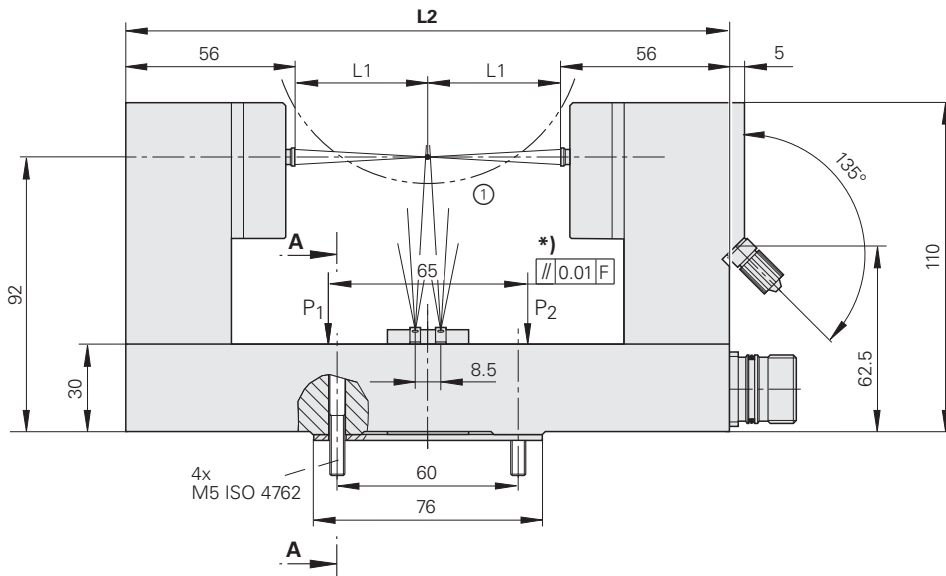

L1	L2	Type
19	150	TL Micro 150
44	200	TL Micro 200
94	300	TL Micro 300

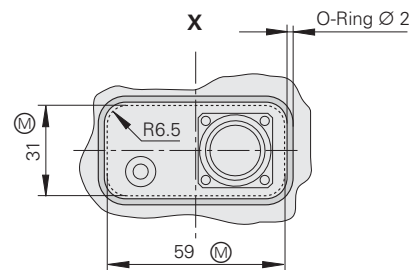
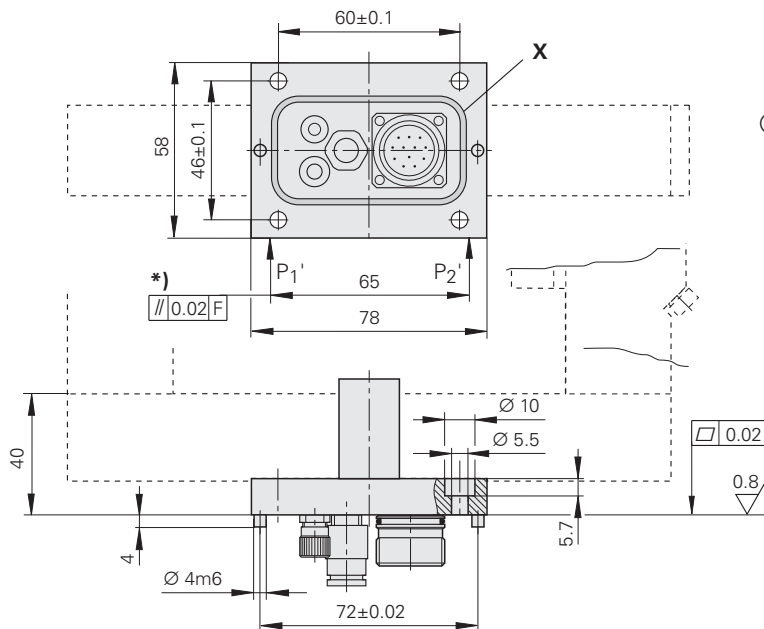

- ① = Tangential measurement of the tool diameter from above
- ② = Tangential measurement of the tool diameter from the side
- Ⓜ = Cutout for mounting
- F = Machine guideway
- P = Gauging points for alignment
- \*) = Alignment of housing

Specifications	TL Micro 150	TL Micro 200	TL Micro 300
<b>Tool diameter</b> Central measurement Tangential measurement from above Tangential measurement, lateral	0.03 to 30 mm 0.03 to 30 mm 0.03 to 30 mm	0.1 to 80 mm 0.1 to 98 mm 0.1 to 122 mm	0.1 to 180 mm 0.1 to 324 mm 0.1 to 428 mm
<b>Repeatability</b>	± 0.2 µm	± 1 µm	
<b>Spindle speed*</b>	Optimized for individual tooth measurement on standard or HSC spindles (> 30000 min <sup>-1</sup> )		
<b>Lasers</b>	Visible red-light laser with beam focused at center of system		
Wavelength/Power	630 to 700 nm / < 1 mW		
Protection class IEC 825	2		
<b>Input signals</b>	Square-wave signals 24 V DC <ul style="list-style-type: none"> <li>• Enable transmitter           ENABLE 0</li> <li>• Enable 1 receiver            ENABLE 1</li> <li>• Enable 2 receiver            ENABLE 2</li> </ul>		
<b>Output signals</b>	Square-wave signals 24 V DC <ul style="list-style-type: none"> <li>• Dynamic triggering signal   DYN</li> <li>• Static triggering signal       STA</li> <li>• Proper laser function        LASER OK</li> </ul>		
<b>Power supply</b>	24 V DC / 160 mA		
<b>Electrical connection*</b>	M23 flange socket (male), 12-pin, either on the side or bottom		
<b>Mounting</b>	Within the machine work envelope		
<b>Protection EN 60529</b>	IP 68 (when connected, with sealing air)		
<b>Tool cleaning</b>	Blower		
<b>Operating temperature</b> <b>Storage temperature</b>	10 °C to 40 °C 0 °C to 50 °C		
<b>Weight</b>	Including blower		
Cable outlet on side (approx.)	0.85 kg	0.95 kg	1.15 kg
Cable outlet on bottom (approx.)	0.90 kg	1.00 kg	1.20 kg

\* Please select when ordering

# DA 301 TL

## Compressed Air Unit for TL Laser System

mm  
Tolerancing ISO 8015  
ISO 2768 - m H  
< 6 mm: ±0.2 mm

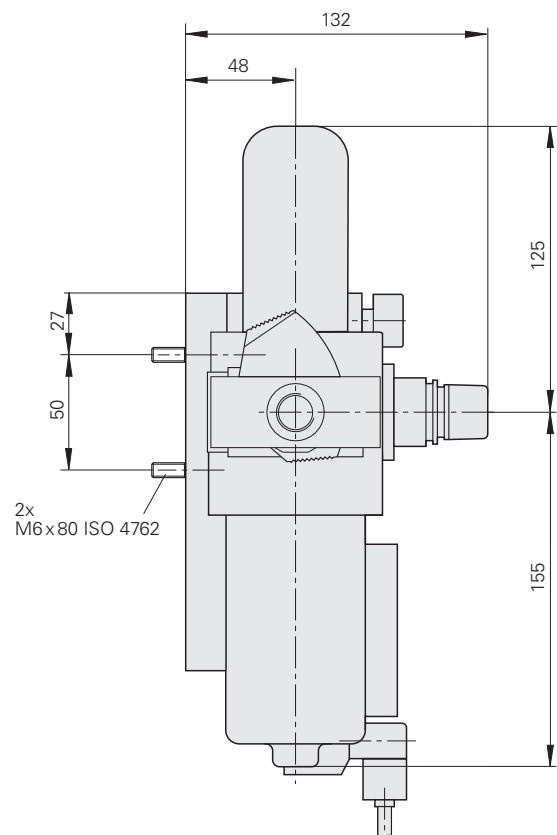
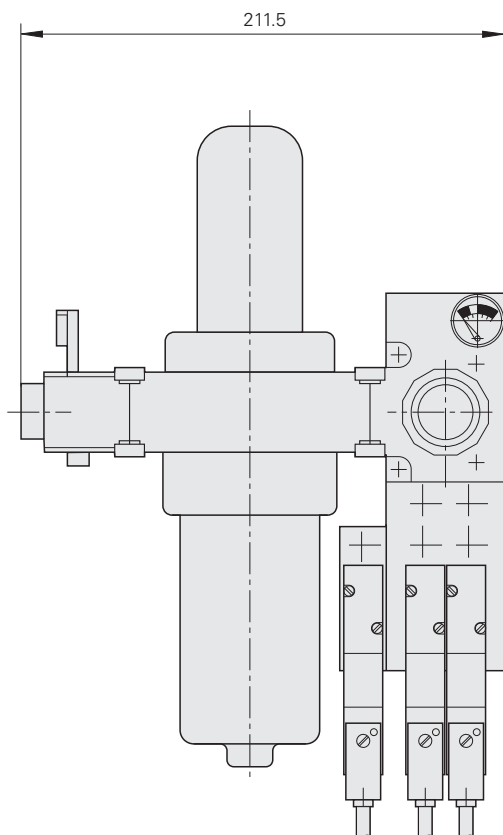

Specifications	DA 301 TL
<b>Mechanical Design</b>	
Filter system	<ul style="list-style-type: none"> <li>• Prefilter for particle sizes down to 5 µm</li> <li>• Fine filter for particle sizes down to 0.01 µm</li> <li>• Activated carbon filter for particle sizes down to 0.001 µm</li> </ul>
Pressure regulator with pressure gauge	For setting the output pressure
Control valves	Release compressed air for <ul style="list-style-type: none"> <li>• Sealing air</li> <li>• Workpiece blower</li> <li>• Sealing unit of the laser optics</li> </ul>
<b>Overpressure for operation</b>	4 to 6 bars
<b>Air quality</b>	
Air inlet	DIN ISO 8573-1 class 4.3.4
Air outlet	DIN ISO 8573-1 Class 1.3.1
<b>Flow rate</b>	≥ 400 l/min (without blower)
<b>Connections</b>	
Inlet for compressed air	G 3/8"
Compressed air outlet	Quick disconnects for <ul style="list-style-type: none"> <li>• Sealing air: Ø 6 mm</li> <li>• Blower: Ø 6 mm</li> <li>• Sealing unit: Ø 4 mm</li> </ul>
<b>Weight</b>	Approx. 4.4 kg (without cable)
<b>Items supplied</b>	DA 301 TL compressed air unit 1 x 13 m pressure tubing Ø 4 mm 2 x 13 m pressure tubing Ø 6 mm 3 x 10 m cable for triggering the control valves



# Power Supply

The cable-connected touch probes **TS 2xx**, **and TT 140**, the **SE** transceiver unit, the **APE 642** interface electronics and the **TL** laser systems are powered by the control. The maximum cable lengths shown in the specifications apply to HEIDENHAIN cables.

The **TS 440**, **TS 64x**, **TS 740** and **TT 449** touch probes with infrared transmission are powered by two batteries (rechargeable or nonrechargeable) with a rated voltage of 1 to 4 V. The service life depends heavily on the type and model of batteries used (see table for examples). The typical service life data shown in the specifications apply only to the lithium batteries included in delivery.

The touch probe electronics automatically detect the type of batteries used. If the battery capacity falls below 10 %, the SE transmits a warning to the control and a red LED simultaneously lights up on the SE.

In order to minimize the current consumption, the touch probe switches to the stand-by mode when the off signal is transmitted, or at the latest, 30 minutes after the last probing. Eight hours later it switches to the sleep mode. You must then take a longer startup time into account when reactivating the touch probe (see *Switching the TS 440/TS 640/TS 740 on/off*)

	Size	Operating time (approx.)		
		Lithium battery	Alkaline battery	NiMH battery
<b>TS 440</b> <b>TT 449</b>	Size $\frac{2}{3}$ AA or Size N (by adapter)	200 h with Sonnenschein SL-761	60 h with Panasonic Lady	45 h (no test)
<b>TS 640</b>	Size C	800 h with Saft LS26500	400 h with Duracell plus	250 h with GP 3500
	Size A (via adapter)	400 h with Saft LS17500	200 h <sup>1)</sup>	125 h <sup>1)</sup>
<b>TS 740</b>	Size C	500 h with Saft LS26500	220 h with Duracell plus	140 h with GP 3500
	Size A (via adapter)	250 h with Saft LS17500	110 h <sup>1)</sup>	70 h <sup>1)</sup>

<sup>1)</sup> Calculated

**Caution:** Never mix types or models of batteries!

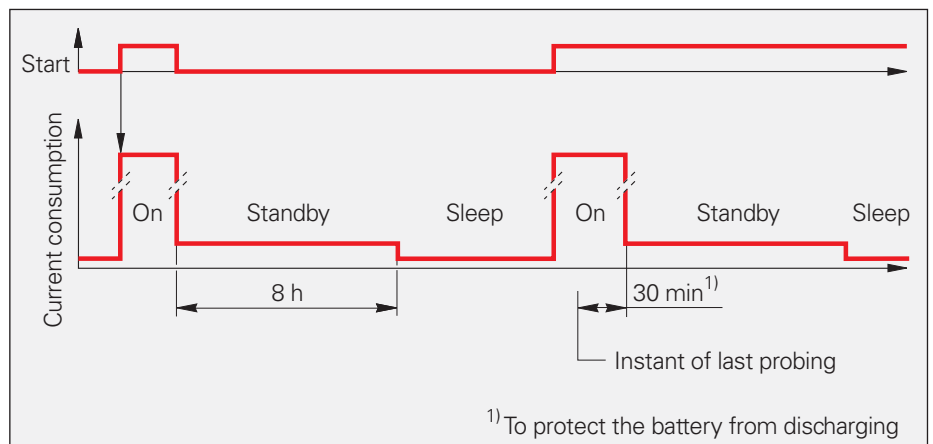

TS 440/TS 640/TS 740/TT 449 current consumption

# TS 444 – Energy Generation through Air Turbine Generator

The **TS 444** touch probe with infrared transmission has an air turbine generator for power generation. Additional rechargeable or nonrechargeable batteries are not required.

## Components

The air turbine generator consists of an air turbine, the actual generator and high-power capacitors for energy storage. Compressed air that is supplied through the spindle is required for operating the turbine. The compressed air can also be used for cleaning the workpiece. Charging the capacitors and cleaning the workpiece are thus combined in one work step. This eliminates such additional idle time.

## Principle of function

After inserting the TS 444 touch probe, the high-power capacitors are charged by the air turbine generator. This can be done when the touch probe moves from the tool changer to the measuring position, and also when the workpiece is cleaned with compressed air.

## Charging times

The charging times of the capacitors depend on the available air pressure: The higher the pressure, the shorter the charging time (see diagram).

## Operating time

When the capacitor is fully charged, the TS 444 is ready for 120 seconds of continuous operation. The battery warning signal reports that the capacitors need to be recharged.

## Requirements for compressed air quality

The air turbine generator can already operate at a minimum pressure of  $2 \times 10^5$  Pa. An operating pressure between  $5.5 \times 10^5$  and  $8 \times 10^5$  Pa is recommended for effective charging. The compressed air does not need to be specially cleaned.

$10^5$  Pa  $\hat{=}$  1 bar

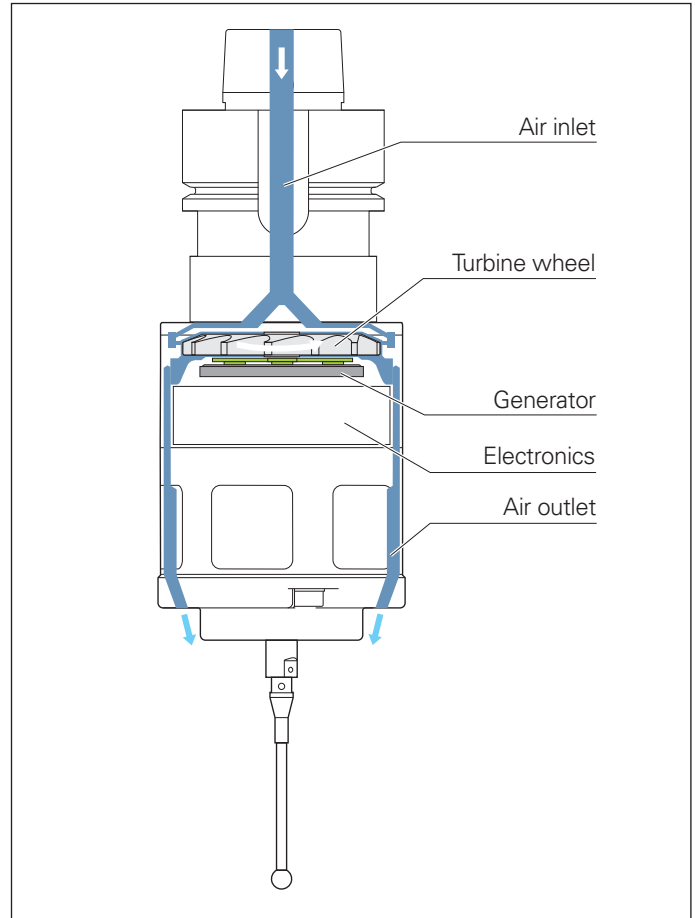
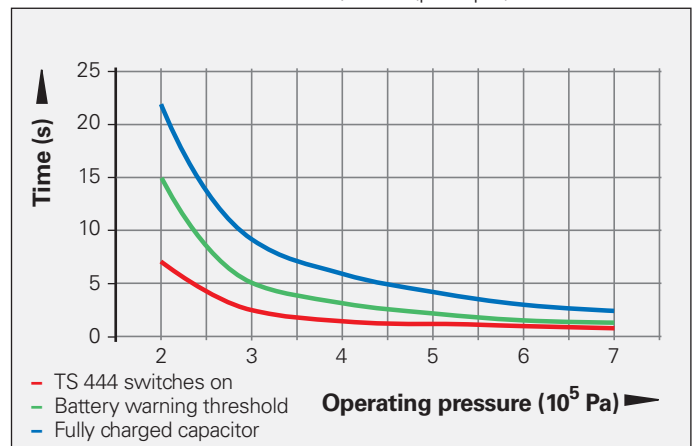

Illustration of turbine and air inlet/outlet (principle)



Charging time as a function of supplied pressure

# Interfaces

## TS and TT Touch Probes

### Touch Probes with Signal Transmission by Cable

When the stylus is deflected, the square-wave **trigger signal S** and its inverted signal  **$\bar{S}$**  are generated.

Since the spindle must be locked in position before the TS can be inserted, the connecting and adapter cables are equipped with jumpers. This enables the CNC to conduct the required safety check when the touch probe is connected.

#### Signal levels

##### $\square$ TTL: TS 220

$U_H \geq 2.5 \text{ V}$  at  $-I_H \leq 20 \text{ mA}$   
 $U_L \leq 0.5 \text{ V}$  with  $I_L \leq 20 \text{ mA}$

##### $\square$ HTL: TS 230/TS 249/TT 140

$U_H \geq (U_P - 4 \text{ V})$  at  $-I_H \leq 20 \text{ mA}$   
 $U_L \leq 2.8 \text{ V}$  at  $I_L \leq 20 \text{ mA}$

Besides the trigger signal in HTL levels, the **TS 249** also features two additional **floating switching outputs** (triggers), normally open or normally closed. This makes the TS 249 particularly universal in its compatibility.

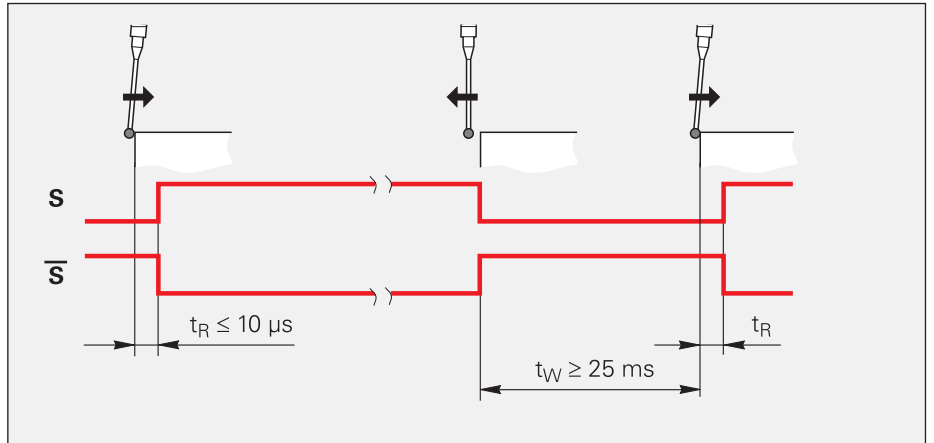

Trigger signal with TS 220/TS 230/TS 249/TT 140

Response time  $t_R \leq 10 \mu\text{s}$

Repeat interval  $t_W > 25 \text{ ms}$

### Touch Probe with Infrared Transmission

The **TS 440, TS 640, TS 740** and **TT 449** touch probes are switched on by the CNC over the SE. The rising edge of the **start signal R** activates the TS, and the falling edge deactivates it.

The **TS 642** touch probe is activated by inserting it in the spindle by a microswitch integrated in the taper shank.

The SE uses the **ready signal B** to report to the control that the touch probe is activated and within the reception area of the SE. The workpiece can now be probed.

The delay  $t$  when switching the probe on or off depends on the distance between the SE and TS, as well as the mode of the touch probe's power supply. Subsequent to the initial activation (when the TS is in standby mode) the typical value for activation is 250 ms, and for deactivation 350 ms (1000 ms for the max. distance). When activating the probe after a longer interval (more than 8 hours—the TS is in the sleep mode), the delay can be up to 3 seconds. If the touch probe does not respond, the SE aborts the switch-on/off attempt after 3.5 seconds.

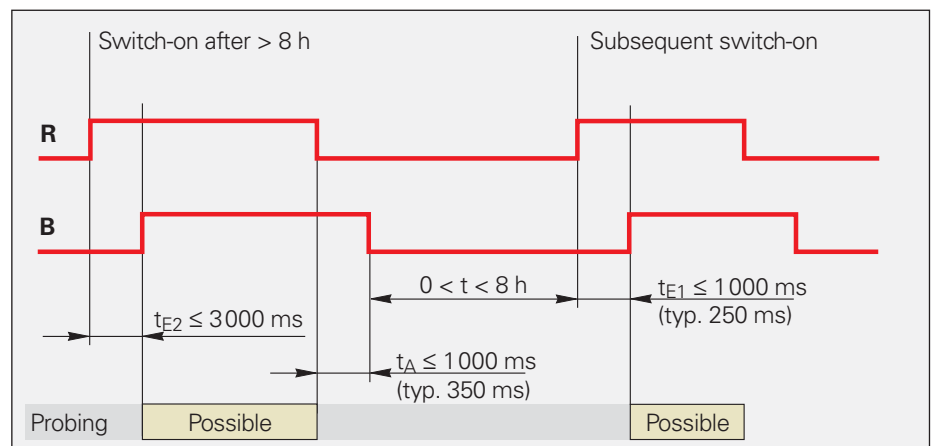

Switching the TS 440/TS 640/TS 740/TT 449 on and off

#### Signal times

Switch-on delay

$t_{E1} \leq 1000 \text{ ms}$  (typically 250 ms)

$t_{E2} \leq 3000 \text{ ms}$

Switch-off delay

$t_A \leq 1000 \text{ ms}$  (typically 350 ms)

The **TS 444** touch probe switches on automatically as soon as the air turbine generator charges the high-power capacitors when compressed air is applied. The SE reports readiness of the TS 444 with the ready signal **B**. Almost simultaneously, the battery warning **W** is switched off. If the charge capacity **L** drops below the warning threshold after approx. 1 min. operating time, the battery warning signals to the NC that recharging is required. After about another minute, the ready signal is reset, as well.

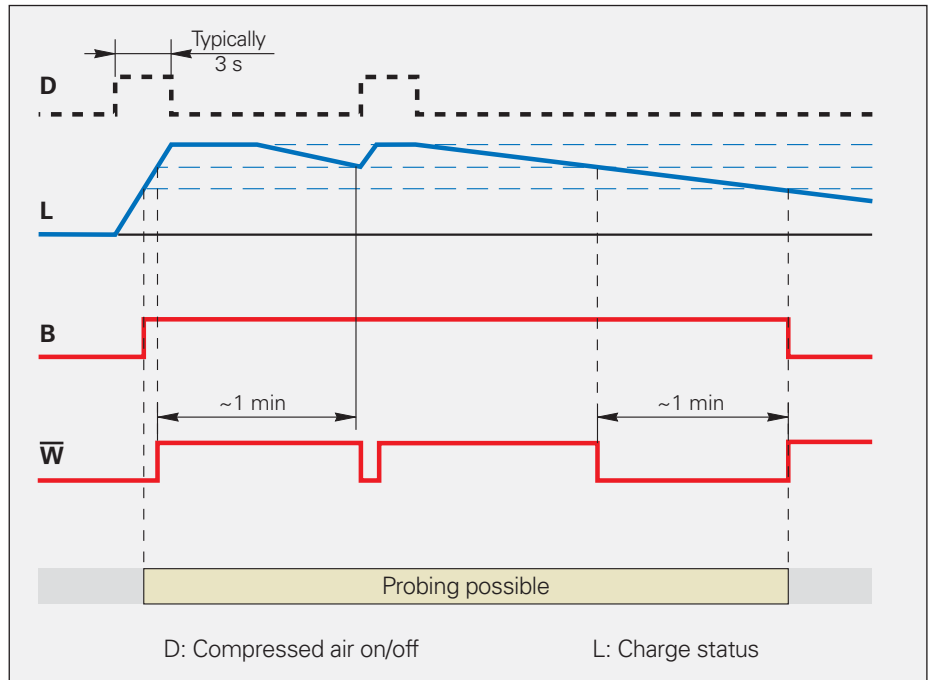

When the stylus is deflected, it releases the square-wave **trigger signal S**.

*Signal times*

- Response time  $t_{R1} \leq 40 \mu s$
- Response time  $t_{R2} \leq 20 ms$
- Repeat interval  $t_W > 25 ms$

Signal sequence of TS 444

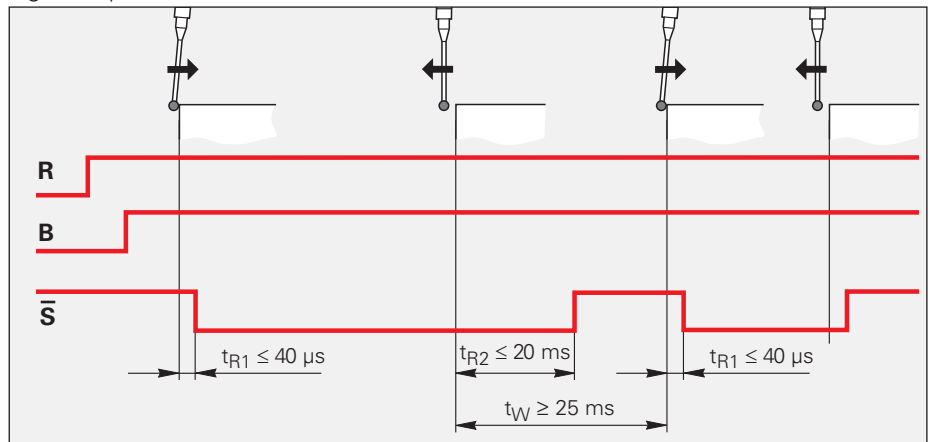

Probing with TS 440/TS 64x/TS 740/TT 449

The **battery warning W** reports that the battery capacity has fallen below 10%. The ready signal also resets the battery warning.

*Signal times*

- Response time  $t_s \leq 20 ms$

**HTL signal levels**

- R**  
 $U_H = (10...30 V)$  at  $I_H \leq 3 mA$   
 $U_L \leq 2 V$  at  $-I_L \leq 0.1 mA$

**R** in APE 642

- $U_H > 0.5 \times U_P$  at  $I_H \leq 2 mA$   
 $U_L < 0.2 \times U_P$  at  $-I_L \leq 0.2 mA$

**B/S/W**

- $U_H \geq (U_P - 2.2 V)$  at  $-I_H \leq 20 mA$   
 $U_L \leq 1.8 V$  at  $I_L \leq 20 mA$

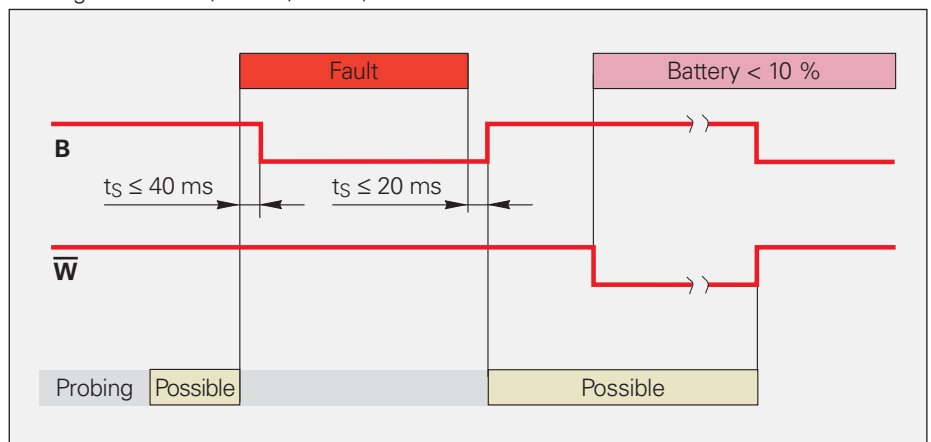

Behavior during disturbance and battery warning

# TL Laser Systems, DA 301 TL

## TL inputs

The CNC activates the laser system through three enabling lines:

The **transmitter enabling signal 0** (ENABLE 0) activates or deactivates the transmitter and switches the laser beam on or off. To reduce the power loss (heat generation) to a minimum and increase service life, the laser diode is activated only during the measuring cycle.

The **receiver enabling signals 1 and 2** (ENABLE 1 and ENABLE 2) determine the operating mode of the laser light barrier depending on the respective measuring cycle.

### Signal level:

$U_H = 24\text{ V}$  at 15 mA

## TL outputs

The TL laser systems provide the following output signals:

After the transmitter and receiver are enabled, the laser system provides the information "**Laser OK**" if the luminance at the receiver is at least 75 % of the maximum.

Two output signals are generated when the laser beam is interrupted.

The **measuring signal static STA** output switches to low level if the luminance at the receiver is less than 50 % (= interrupted light beam).

Do not use this output as trigger signal. Fast rotating tools cause spike pulses with extremely short pulse times that cannot be evaluated by the PLC or NC.

The **measuring signal dynamic DYN** output provides a 24 V pulse with a defined duration of 20 ms for every light modulation (light to dark or dark to light). This output serves for the trigger signal.

### Signal level:

$U_H = 24\text{ V}$  at 50 mA

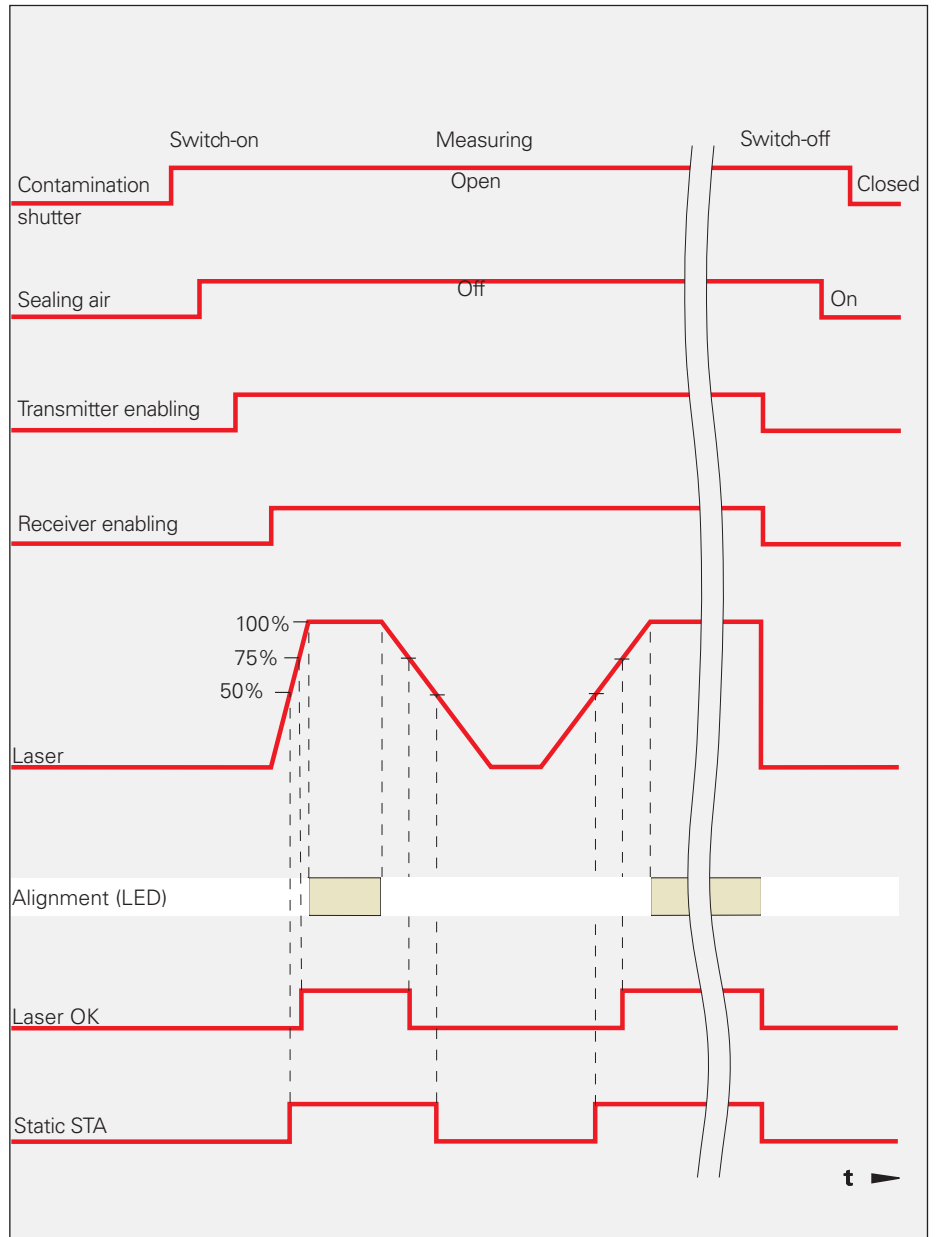

Switch-on/switch-off behavior

## DA 301 TL inputs

The DA 301 TL supplies the laser systems with clean compressed air for contamination protection, for opening the seal and cleaning the tool. The respective **pneumatic valves** are controlled by the CNC. The cables to the CNC are included in delivery with the DA 301 TL.

### Signal level:

$U_H = 24\text{ V}$  at 71 mA

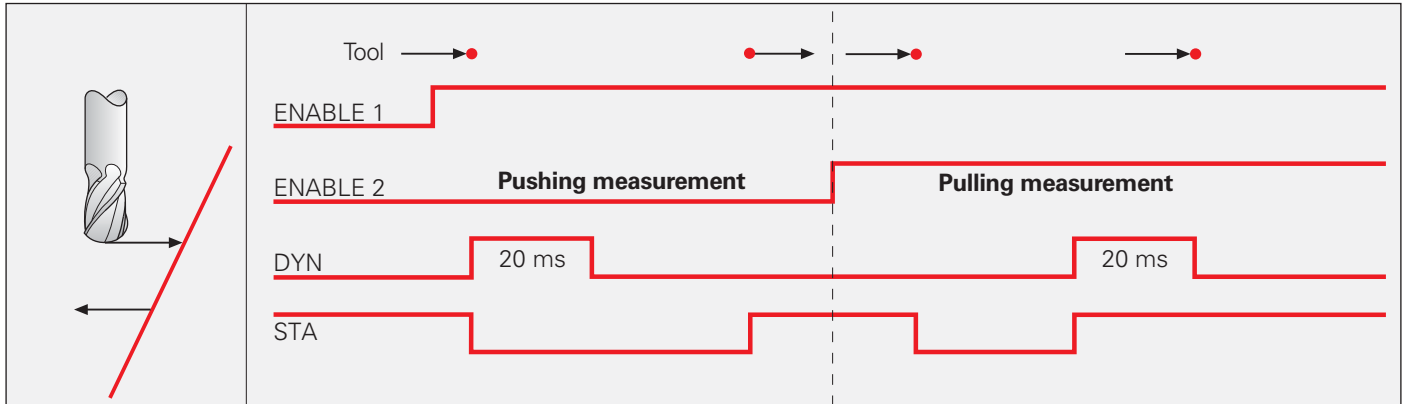

Output signals during length and radius measurement for pushing and pulling measurement

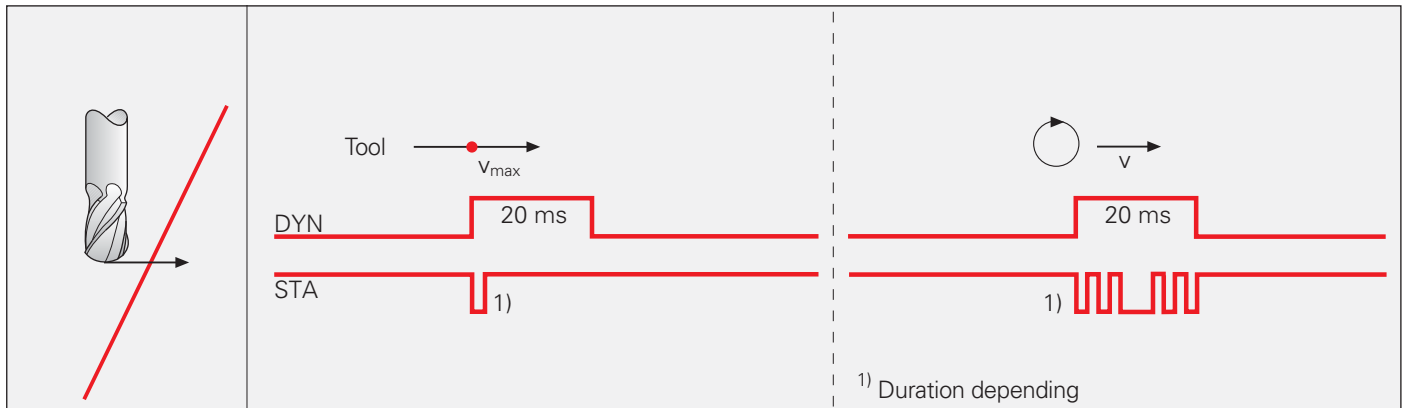

Fast axis feed rates or rotating tools can cause spike pulses in the STA signal

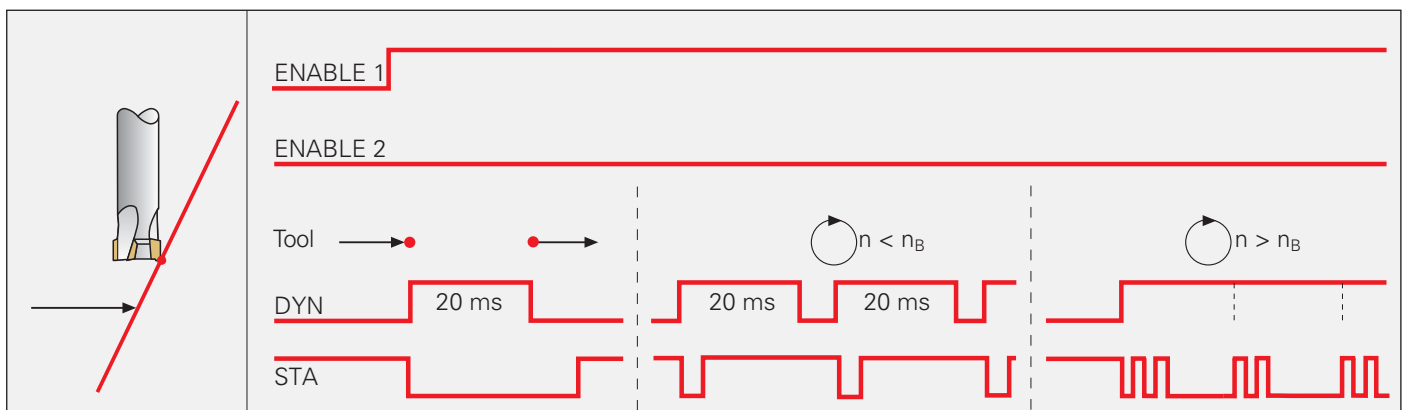

Output signals during shape inspection of individual teeth

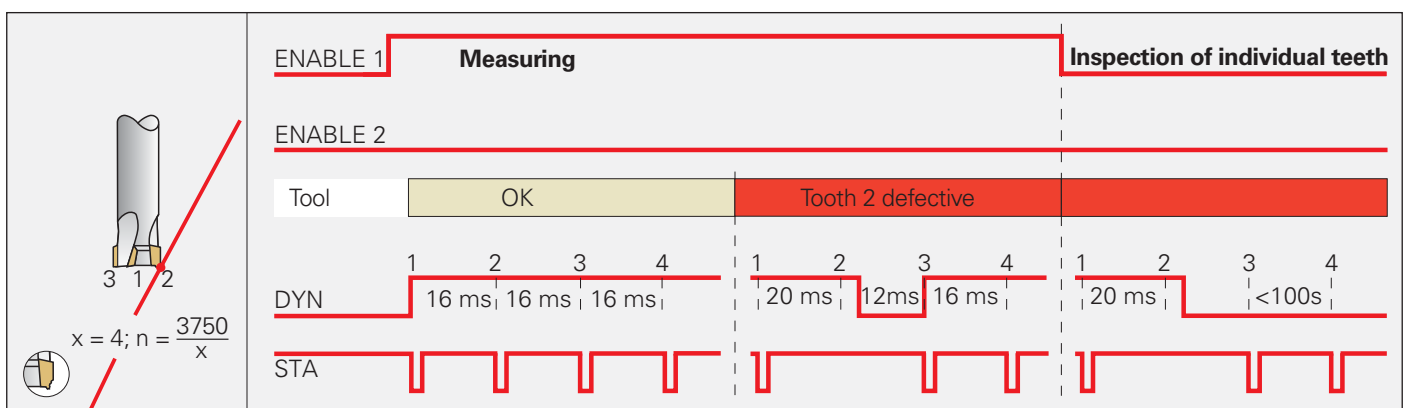

Output signals during tooth inspection in the measuring and individual tooth inspection modes.

# Universal Touch Probe Interface

The UTI 192 converts the output signals of the HEIDENHAIN touch probe to machine control signals in accordance with DIN EN 61 131-2. It supports two HEIDENHAIN touch probes: TT tool touch probes and TS workpiece touch probes.

Now you can enjoy the benefits of the touch trigger probe from HEIDENHAIN with most NC controls for milling machines, drilling and boring machines, and machining centers.

This is possible because with the new UTI 192 universal touch probe interface they are also **compatible with all NC controls** with a fast switching input.

Of course, the probing functions actually available depend on the software cycles implemented in the respective NC control. For certain controls, HEIDENHAIN offers **special probing cycles** for automatic alignment and measurement of workpieces, workpiece presetting, and tool measurement (for more information: *Touch Probe Cycles for FANUC Controls Product Information*).

The UTI 192 features a **compact design**. It can be quickly fastened on a standard mounting rail (DIN 46227 and EN 50022) in the electrical cabinet.

The UTI features a wide range of **interfacing possibilities** so that the touch probes can easily be connected to the different NC controls. It is possible, for example, to configure the output signals as active-high or active-low. In addition, it is possible to connect the inputs or outputs with logical operations. The UTI also provides various routines for switching on the TS 440 and TS 640 infrared touch probes.

The UTI 192 is provided with LEDs for configuration and **easy servicing for initial operation**. The LEDs indicate whether power is on and show the levels of the inputs and outputs. The selected touch probe and its status are also displayed.

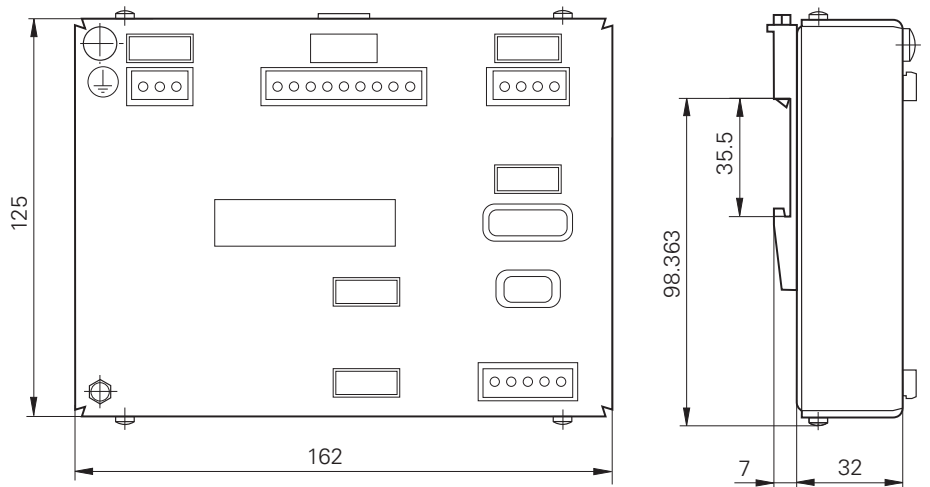
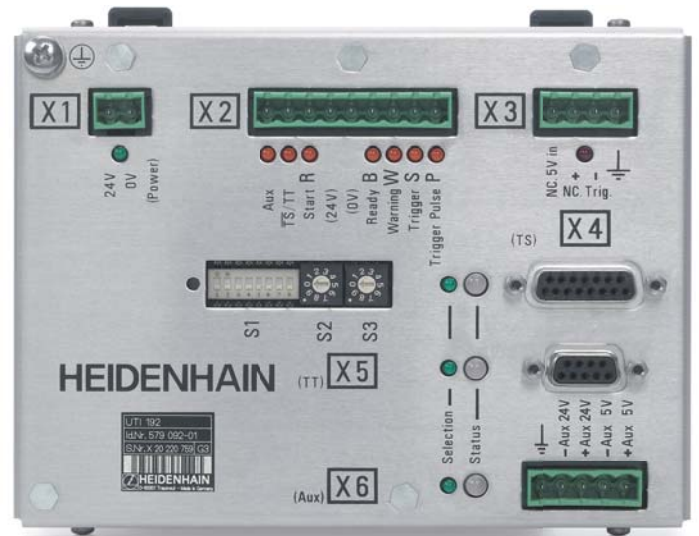

	UTI 192
<b>Power supply</b>	24 V DC $-20/+25\%$ stabilized direct voltage
<b>Current consumption</b>	Without touch probe: max. 180 mA With TS and/or TT: max. 800 mA
<b>Protection IEC 60529</b>	IP 30
<b>Weight</b>	0.35 kg
<b>Operating temperature</b>	10 °C to 60 °C
<b>Storage temperature</b>	-20 °C to 70 °C
<b>Electrical connections</b>	<ul style="list-style-type: none"> <li>TS D-sub female, 15-pin; cable length 50 m<sup>1)</sup></li> <li>TT D-sub female, 9-pin; cable length 50 m<sup>1)</sup></li> <li>PLC COMBICON<sup>2)</sup>; cable length 20 m with <math>\varnothing \geq 0.25 \text{ mm}^2</math></li> <li>NC COMBICON<sup>2)</sup>; cable length 5 m with <math>\varnothing \geq 0.25 \text{ mm}^2</math> (shielded)</li> <li>AUX COMBICON<sup>2)</sup>; cable length 5 m with <math>\varnothing \geq 0.25 \text{ mm}^2</math></li> <li>U<sub>P</sub> COMBICON<sup>2)</sup>; cable length 20 m with <math>\varnothing \geq 1 \text{ mm}^2</math></li> </ul>

<sup>1)</sup> With HEIDENHAIN cable

<sup>2)</sup> Phoenix COMBICON connector included in delivery

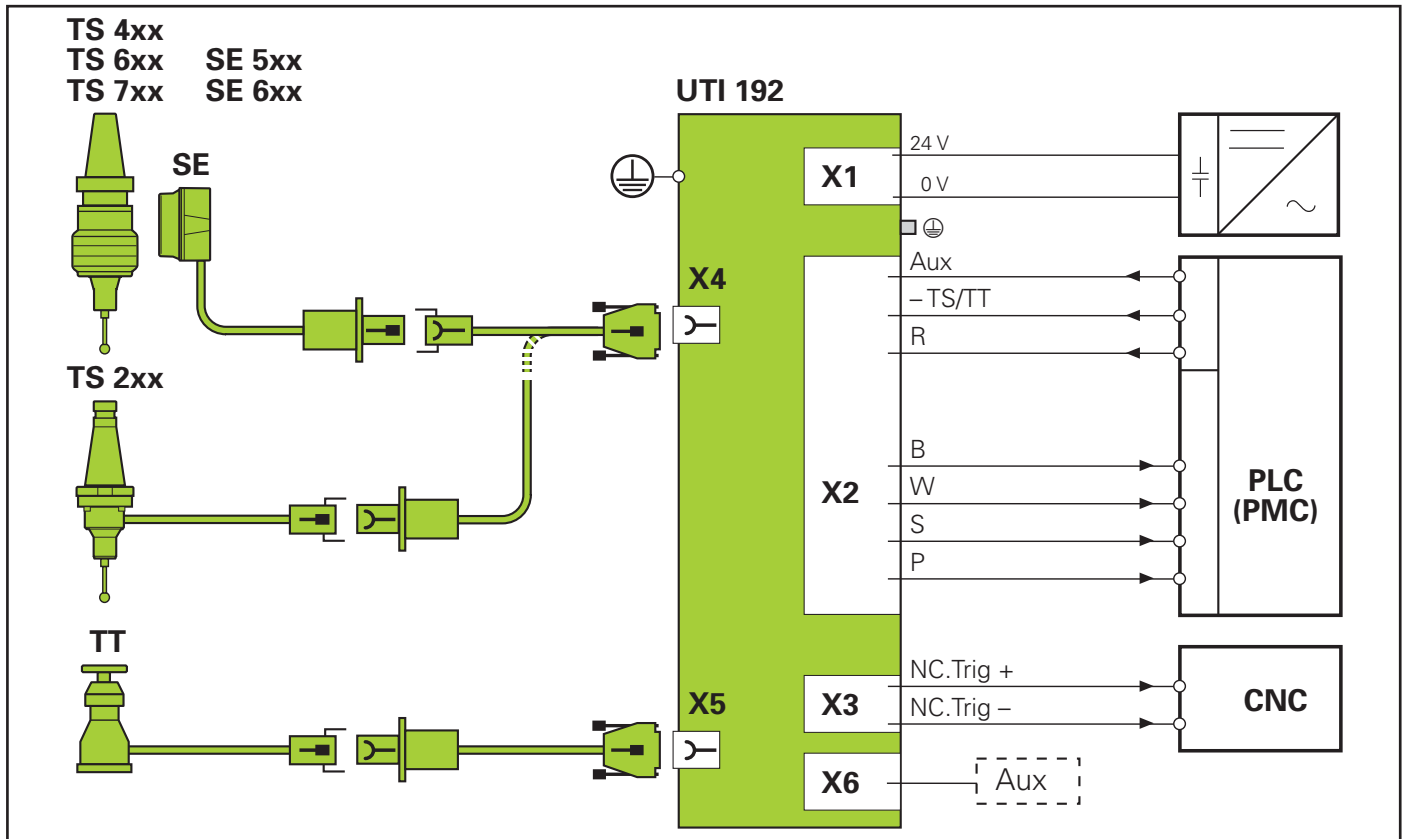

### X1 Power supply

Power supply connection for the UTI and the connected touch probes.

### X2 Connection to PLC (PMC)

**Output signals** according to EN 61 131-2

- Output current max. 0.5 A
- Signal level: high-side driver
- Active level selectable by switch
- Logical combination of output signals possible

#### S: Trigger signal

The trigger signal is generated upon deflection of the stylus.

#### P: Pulsed trigger signal

A pulsed trigger signal is generated upon deflection of the stylus.

#### B: Ready signal

Indicates that touch probe is ready for operation (touch probe is switched on, infrared transmission is active).

#### W: Warning (with TS 4xx/6xx)

Indicates, for example, low battery charge.

### Input signals according to EN 61 131-2

#### TT/TS: Selection of TT or TS

High level at this control input selects the touch probe at connection X5 (TT). Low level (open) selects the touch probe at connection X4 (TS).

#### Aux: Selection of Aux or TT/TS

Switching between the touch probe inputs TS (X4) or TT (X5) and the Aux input (X6).

#### Start (with TS 64x/44x)

With this output you can activate a touch probe at connection X4. The active level is selectable by switch.

Pin	Signal
1	<b>Aux</b>
2	<b>TS/TT</b>
3	<b>R</b>
4*	24 V (max. 10 mA) output
5*	0V output
6	<b>B</b>
7	<b>W</b>
8	<b>S</b>
9	<b>P</b>

\* 24 V, 0 V only for fixed assignment of inputs 1 and 2

### X3 Connection to NC

Additional floating output of trigger signal (low-active, open collector output)

Pin	Signal
1	5 V in
2	+ NC trigger
3	- NC trigger
4	Cable shield/functional ground

### X4 Connection for TS

### X5 Connection for TT

### X6 Auxiliary

Two universal, electrically isolated switching inputs

Pin	Signal	
1	+ 5 V	Aux 5 V
2	0 V	
3	+24 V	Aux 24 V
4	0 V	
5	Functional ground	



# Cables and Connecting Elements

## General Information

**Connector (insulated):** A connecting element with a coupling ring. Available with male or female contacts.

Symbols  

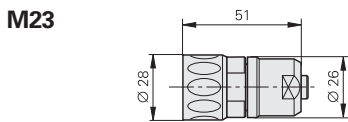

**Coupling (insulated):** Connecting element with external thread; available with male or female contacts.

Symbols  

**Mounted coupling with flange**

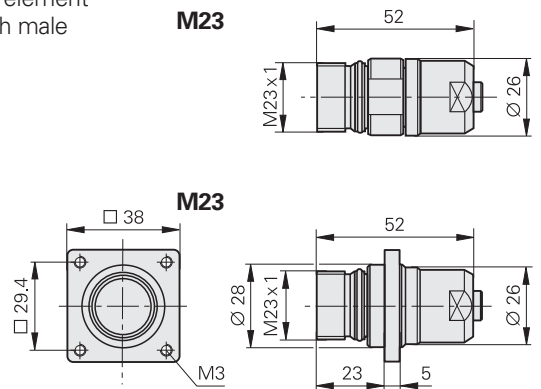

**Flange socket:** Permanently mounted on the encoder or a housing, with external thread (like a coupling), available with male or female contacts.

Symbols  

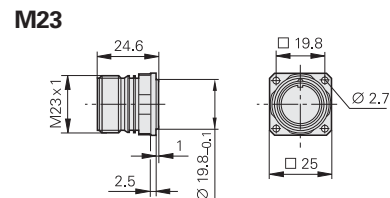

**Quick disconnect:** Compact connector on TS 220 with push/pull lock

Symbol 

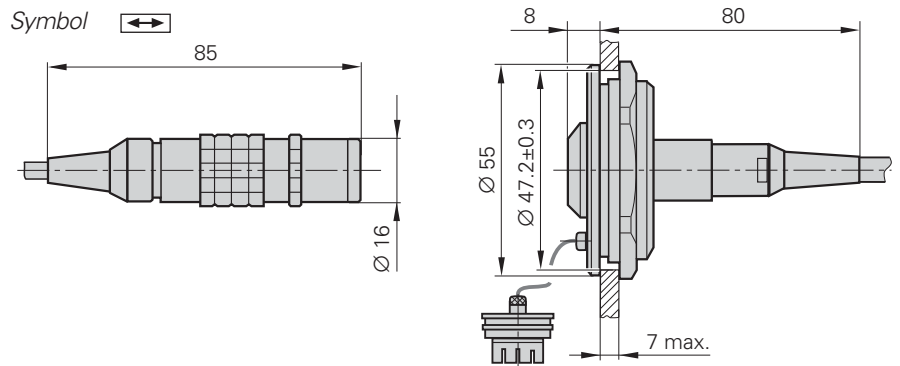

**D-sub connector:** For HEIDENHAIN controls, counters and IK absolute value cards.

Symbols  

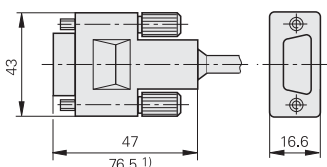

<sup>1)</sup> With integrated interpolation electronics

The pins on connectors are **numbered** in the direction opposite to those on couplings or flange sockets, regardless of whether the connecting elements are

Male contacts or    
 Female  

When engaged, the connections are **protected** to IP 67 (D-sub connector: IP 50; EN 60 529). When not engaged, there is no protection.

**Accessories for flange sockets and M23 mounted couplings**

**Bell seal**  
ID 266526-01

**Threaded metal dust cap**  
ID 219926-01

## Cables

### Durability

All encoders have polyurethane (PUR) cables. PUR cables are resistant to oil, hydrolysis and microbes in accordance with **VDE 0472**. They are free of PVC and silicone and comply with UL safety directives. The **UL certification** AWM STYLE 20963 8 0 °C 30 V E63216 is documented on the cable.

### Bend radius

The permissible bend radii R depend on the cable diameter and the configuration:

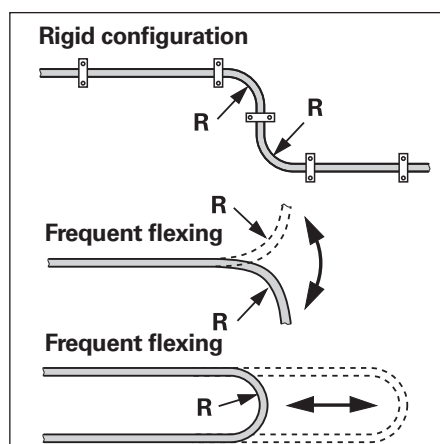

Cables	Bend radius R	
	Rigid configuration	Frequent flexing
Ø 4.5 mm	≥ 10 mm	≥ 50 mm
Ø 6 mm Ø 10 mm <sup>1)</sup>	≥ 20 mm ≥ 35 mm	≥ 75 mm ≥ 75 mm
Ø 8 mm Ø 14 mm <sup>1)</sup>	≥ 40 mm ≥ 100 mm	≥ 100 mm ≥ 100 mm

<sup>1)</sup> Metal armor

# Pin Layouts and Adapter Cables

## SE 540, SE 640, APE 642

### SE 540

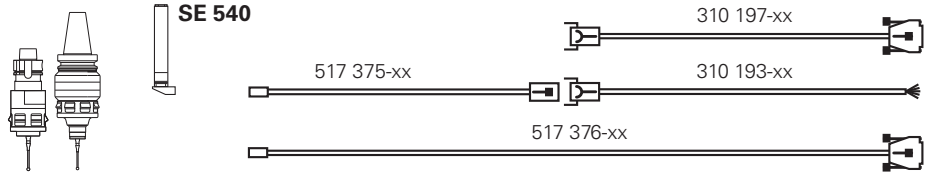

**Adapter cable to SE 540, Ø 4.5 mm**  
**With coupling (male), 7-pin**  
 ID 517 375-xx

**With D-sub connector (male), 15-pin**  
 ID 517 376-xx

**Adapter cable Ø 8 mm**  
**Complete** with M23 connector, 7-pin, female and D-sub connector (male), 15-pin  
 ID 310 197-xx

**With one M23 connector** (female), 7-pin  
 ID 310 193-xx

### SE 640

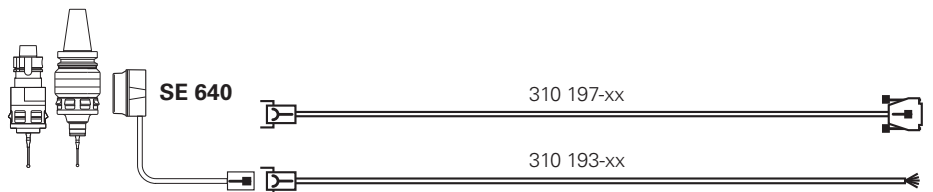

### Two SE 640 units to APE 642

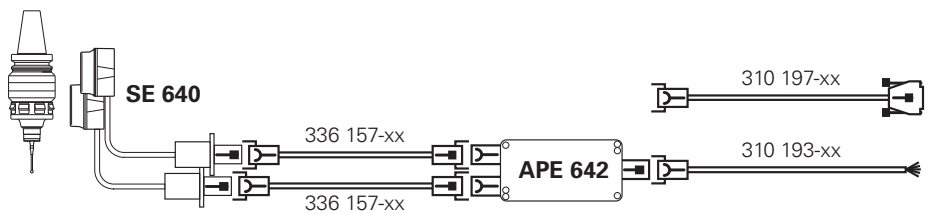

**Extension cable Ø 8 mm**  
**Complete** with M23 connector, 7-pin, female and M23 connector (male), 7-pin  
 ID 336 157-xx

**Adapter cable Ø 8 mm**  
**Complete** with M23 connector, 7-pin, female and D-sub connector (male), 15-pin  
 ID 310 197-xx

**With one M23 connector** (female), 7-pin  
 ID 310 193-xx

7-pin M23 coupling		7-pin M23 connector		15-pin D-sub connector			
	Power supply			Signals			
	2	1	7	3	5	4	6
	5	8	1	4	3	10	7
	Up	0V	Internal shield	R	B	S	W
	Brown	White	White/Brown	Yellow	Gray	Green	Blue

**External shield** is on housing. Unused pins or wires must not be engaged.

Up = power supply; R = start signal; B = ready signal; S = trigger signal; W = battery warning

# Adapter Cable SE 642

## Connection to iTNC 530 (MC 4xx)

A UTI 240 touch probe interface is required if the SE 642 is driven with TS and TT 449. If the SE 642 is to operate only a TS, it can be connected without UTI over an additional adapter cable to the X12.

**Adapter cable SE 642** with 12-pin M12 connector (female) and D-sub connector (male, 3-row)  
15-pin ID 663 631-xx

**UTI 240 adapter cable – iTNC 530** with D-sub connector (male and female)  
X12 (15-pin) ID 663 508-xx  
X13 (9-pin) ID 663 511-xx

**SE 642 adapter cable to X12**  
D-sub coupling (female, 3-row) and D-sub connector (male)  
15-pin ID 701 919-xx

## UTI 240 touch probe interface

The UTI 240 touch-probe interface distributes the TS and the TT signals to the corresponding inputs of the iTNC and sets up a connection to the PLC for starting the TT and for transmitting the warning signal. For simple commissioning and configuration, LEDs indicate the active touch probe and the switching states of the inputs and outputs.

UTI 240 ID 658 883-xx

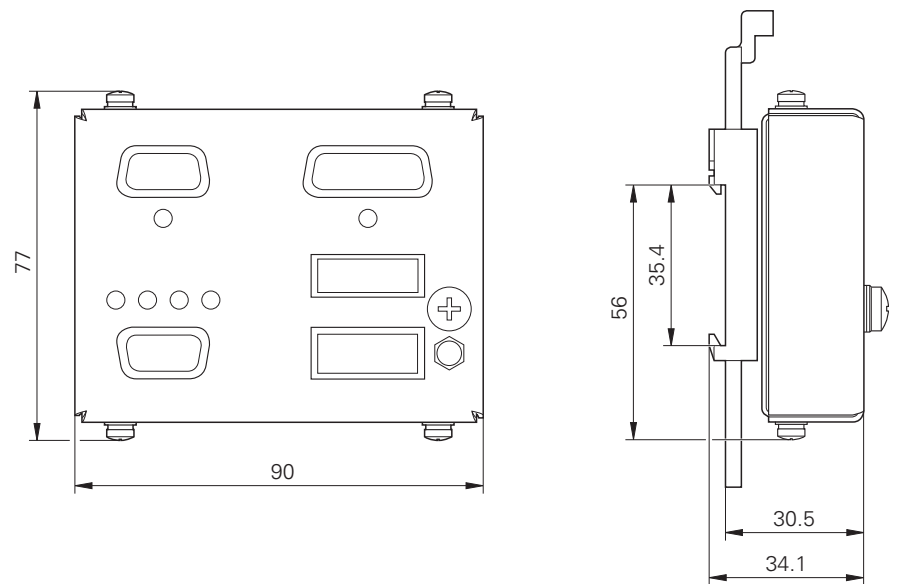
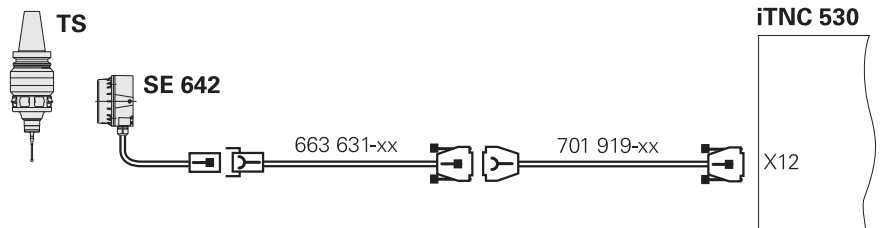
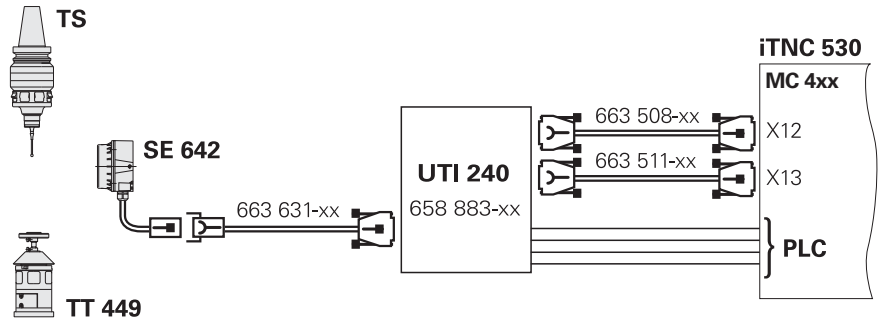

## Connection to iTNC 530 HSCI, TNC 6xx

The TNC with HSCI can be directly connected to the SE 642 via an SE 642 adapter cable.



**Adapter cable SE 642** with 12-pin M12 connector (female) and D-sub connector (male, 3-row) 15-pin ID 663 631-xx

### Please note:

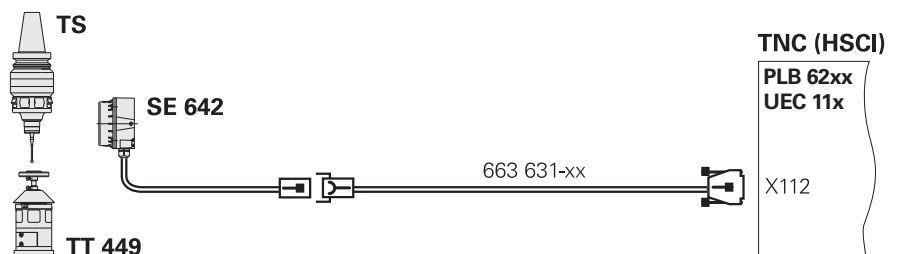
At present, the TNC 620 does not yet support the TT 449. Until NC software 60642x-02, the iTNC 530 HSCI cannot be switched between TS and TT on one connection. Until then, in both cases the TT 140 can be used on connection X113.



# Pin Layout SE 642

12-pin coupling, M12												
	Power supply		Signals									
	<b>1</b>	<b>12</b>	<b>11</b>	<b>5</b>	<b>2</b>	<b>10</b>	<b>3</b>	<b>4</b>	<b>6</b>	<b>9</b>	<b>7</b>	<b>8</b>
	<b>U<sub>P</sub></b>	<b>0V</b>	<b>R(TS)</b>	<b>R(TT)</b>	<b>B(TS)</b>	<b>B(TT)</b>	<b>S</b>	<b><math>\bar{S}</math></b>	<b><math>\bar{W}</math></b>	<b>/</b>	<b>/</b>	<b>/</b>
	Brown/ Green	White/ Green	Blue	White	Green	Brown	Gray	Pink	Violet	Yellow	Red	Black

**External shield** is on housing. Unused pins or wires must not be engaged.

**U<sub>P</sub>** = power supply; **R** = start signal; **B** = ready signal; **S**,  **$\bar{S}$**  = trigger signal;  **$\bar{W}$**  = battery warning



# Adapter Cables and Pin Layout TS 249

## TS 249 adapter cable

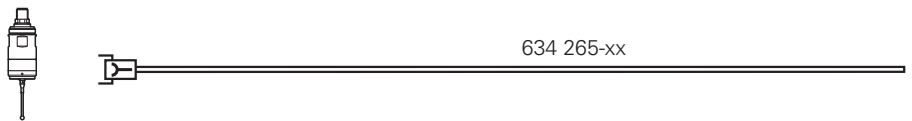
With M12 connector (female), 8-pin  
ID 634 265-xx



TS 249

8-pin connector M12								
	Power supply		Signals					
	<b>2</b>	<b>7</b>	<b>3</b>	<b>4</b>	<b>1</b>	<b>5</b>	<b>6</b>	<b>8</b>
	<b>U<sub>P</sub></b> 15V to 30V	<b>U<sub>N</sub></b> 0V	<b>S</b>	<b><math>\bar{S}</math></b>	<b>B</b>	<b>Trigger</b> NO	<b>Trigger</b> NC	<b>Trigger</b> 0V
	Blue	Violet	Gray	Pink	White	White/Green	Yellow	Brown/Green

**External shield** is on housing. Unused pins or wires must not be engaged.

**U<sub>P</sub>** = power supply; **B** = ready signal; **S**,  **$\bar{S}$**  = trigger signal;  
Trigger = Floating switching outputs (NC = normally closed, NO = normally open)

# Pin Layouts and Adapter Cables

## TS 220, TS 230

### TS 220 Assignment

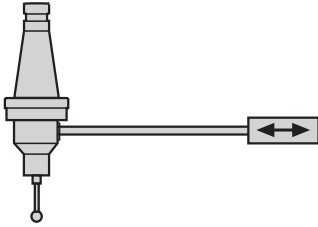

**Adapter cable Ø 8 mm  
Complete** with mounted coupling for quick disconnect and D-sub connector (male), 15-pin  
ID 274543-xx



**Adapter cable Ø 8 mm  
With one mounted coupling** for quick disconnect  
ID 274544-xx



### TS 230 Assignment

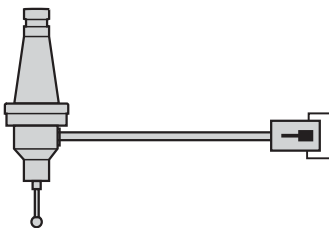

**Adapter cable Ø 8 mm  
With one M23 mounted coupling** (female), 7-pin  
ID 310194-xx



Quick disconnect						
	Power supply		Signal		Others	
	2	1	5	6	3	4
	$U_P$	$U_N$	S	$\bar{S}$		
	Brown	White	Green	Yellow	/	/

Mounted coupling for quick disconnect				15-pin D-sub connector			
	Power supply		Signal		Others		
	2	1	5	6	3	4	
	$U_P$	$U_N$	S	$\bar{S}$	/	/	/
	Brown/ Green	White/ Green	Green	Yellow	Gray	Pink	Gray
	6	8	9	10	5	3	7

7-pin M23 connector							
	Power supply		Signal		Others		
	2	1	3	4	5	6	7
	$U_P$	$U_N$	S	$\bar{S}$			/
	Brown	White	Green	Yellow	/	/	/

7-pin M23 coupling							
	Power supply		Signal		Others		
	2	1	3	4	5	6	7
	$U_P$	$U_N$	S	$\bar{S}$	/	/	/
	Brown/ Green	White/ Green	Brown	Green	Gray	Pink	/

**Outside shield** on housing;  $U_P$  = power supply voltage  
S;  $\bar{S}$  = trigger signal

# TT 140

## TT 140 Assignment



7-pin M23 connector							
	Power supply		Signal		Others		
	2	1	3	4	5	6	7
	$U_P$	$U_N$	$S$	$\bar{S}$			/
	Brown	White	Green	Yellow	/	/	/

## Adapter cable Ø 8 mm

Complete with M23 mounted coupling (female), 7-pin and D-sub connector (male), 9-pin  
ID 335332-xx



7-pin M23 coupling				9-pin D-sub connector			
	Power supply		Signal		Others		
	2	1	3	4	5	6	7
	$U_P$	$U_N$	$S$	$\bar{S}$	/	/	/
	Brown/ Green	White/ Green	Brown	Green	/	Pink	/
	4	2	8	9	5	1	3/6/7

## Adapter cable Ø 8 mm

With one M23 mounted coupling (female), 7-pin  
ID 310194-xx



7-pin M23 coupling							
	Power supply		Signal		Others		
	2	1	3	4	5	6	7
	$U_P$	$U_N$	$S$	$\bar{S}$	/	/	/
	Brown/ Green	White/ Green	Brown	Green	Gray	Pink	/

**Shield** on housing;  $U_P$  = power supply voltage  
 $S$ ;  $\bar{S}$  = trigger signal

# Pin Layouts and Adapter Cables

## TL, DA 301 TL

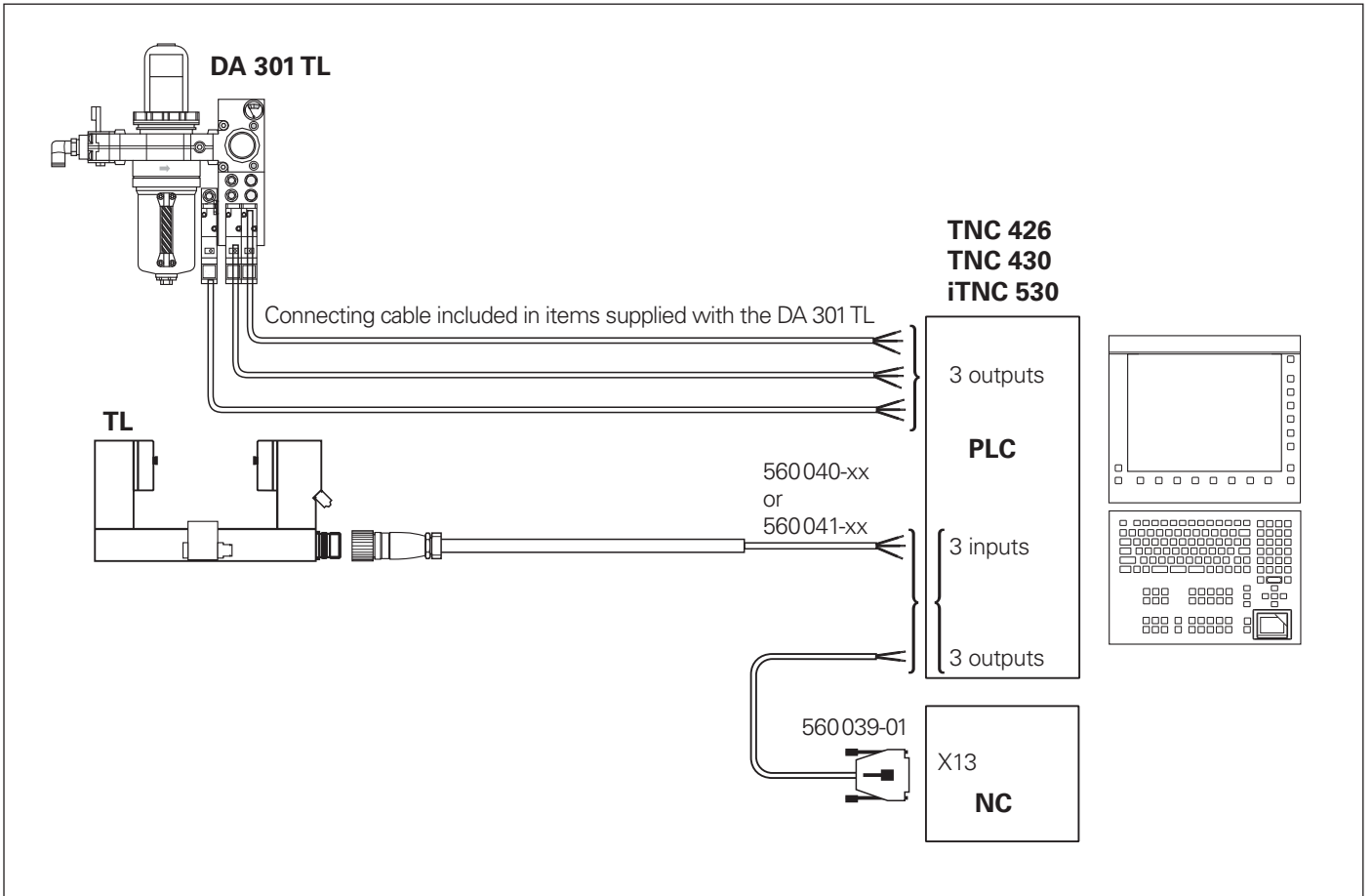

**Adapter cable Ø 14 mm/Ø 6.5 mm**  
**With one** M23 connector (female), 12-pin  
 Smallest permissible bending radius  
 60 mm, suitable for use in drag chains

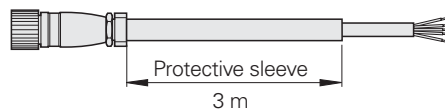



With PUR protective sleeve  
 ID 560040-xx

**Adapter cable**  
**With one** D-sub connector (male), 9-pin  
 Integrated interface for TNC 426/430,  
 iTNC 530



Length 5 m  
 ID 560039-xx

### TL Laser System

12-pin connector, M23								
	Power supply		Signals			Outputs		
	<b>2</b>	<b>1</b>	<b>4</b>	<b>12</b>	<b>6</b>	<b>3</b>	<b>5</b>	<b>7</b>
	<b>24V</b>	<b>0V</b>	<b>ENABLE 0</b>	<b>ENABLE 1</b>	<b>ENABLE 2</b>	<b>DYN</b>	<b>STA</b>	<b>LASER OK</b>
	Brown	White	Yellow	Pink	Violet	Green	Gray	Blue

9-pin D-sub connector		
	Inputs	
	<b>0V</b>	<b>DYN</b>
	White	Brown

3-pin connector			
	Outputs		
	<b>Trigger signal</b>	<b>0V</b>	<b>Ground</b>
	Black	Black	Yellow/Green



# HEIDENHAIN

## DR. JOHANNES HEIDENHAIN GmbH

Dr.-Johannes-Heidenhain-Straße 5

83301 Traunreut, Germany

☎ +49 8669 31-0

FAX +49 8669 5061

E-mail: info@heidenhain.de

www.heidenhain.de

Vollständige und weitere Adressen siehe [www.heidenhain.de](http://www.heidenhain.de)  
For complete and further addresses see [www.heidenhain.de](http://www.heidenhain.de)

<b>DE</b>	<b>HEIDENHAIN Technisches Büro Nord</b> 12681 Berlin, Deutschland ☎ 030 54705-240	<b>ES</b>	<b>FARRESA ELECTRONICA S.A.</b> 08028 Barcelona, Spain www.farresa.es	<b>PH</b>	<b>Machinebanks` Corporation</b> Quezon City, Philippines 1113 E-mail: info@machinebanks.com
	<b>HEIDENHAIN Technisches Büro Mitte</b> 08468 Heinsdorfergrund, Deutschland ☎ 03765 69544	<b>FI</b>	<b>HEIDENHAIN Scandinavia AB</b> 02770 Espoo, Finland www.heidenhain.fi	<b>PL</b>	<b>APS</b> 02-489 Warszawa, Poland www.apservis.com.pl
	<b>HEIDENHAIN Technisches Büro West</b> 44379 Dortmund, Deutschland ☎ 0231 618083-0	<b>FR</b>	<b>HEIDENHAIN FRANCE sarl</b> 92310 Sèvres, France www.heidenhain.fr	<b>PT</b>	<b>FARRESA ELECTRÓNICA, LDA.</b> 4470 - 177 Maia, Portugal www.farresa.pt
	<b>HEIDENHAIN Technisches Büro Südwest</b> 70771 Leinfelden-Echterdingen, Deutschland ☎ 0711 993395-0	<b>GB</b>	<b>HEIDENHAIN (G.B.) Limited</b> Burgess Hill RH15 9RD, United Kingdom www.heidenhain.co.uk	<b>RO</b>	<b>HEIDENHAIN Reprezentantă Romania</b> Braşov, 500338, Romania www.heidenhain.ro
	<b>HEIDENHAIN Technisches Büro Südost</b> 83301 Traunreut, Deutschland ☎ 08669 31-1345	<b>GR</b>	<b>MB Milionis Vassilis</b> 17341 Athens, Greece www.heidenhain.gr	<b>RS</b>	Serbia → <b>BG</b>
		<b>HK</b>	<b>HEIDENHAIN LTD</b> Kowloon, Hong Kong E-mail: sales@heidenhain.com.hk	<b>RU</b>	<b>OOO HEIDENHAIN</b> 125315 Moscow, Russia www.heidenhain.ru
<b>AR</b>	<b>NAKASE SRL.</b> B1653AOX Villa Ballester, Argentina www.heidenhain.com.ar	<b>HR</b>	Croatia → <b>SL</b>	<b>SE</b>	<b>HEIDENHAIN Scandinavia AB</b> 12739 Skärholmen, Sweden www.heidenhain.se
<b>AT</b>	<b>HEIDENHAIN Techn. Büro Österreich</b> 83301 Traunreut, Germany www.heidenhain.de	<b>HU</b>	<b>HEIDENHAIN Kereskedelmi Képviselet</b> 1239 Budapest, Hungary www.heidenhain.hu	<b>SG</b>	<b>HEIDENHAIN PACIFIC PTE LTD.</b> Singapore 408593 www.heidenhain.com.sg
<b>AU</b>	<b>FCR Motion Technology Pty. Ltd</b> Laverton North 3026, Australia E-mail: vicsales@fcrmotion.com	<b>ID</b>	<b>PT Servitama Era Toolsindo</b> Jakarta 13930, Indonesia E-mail: ptset@group.gts.co.id	<b>SK</b>	<b>KOPRETINA TN s.r.o.</b> 91101 Trenčín, Slovakia www.kopretina.sk
<b>BA</b>	Bosnia and Herzegovina → <b>SL</b>	<b>IL</b>	<b>NEUMO VARGUS MARKETING LTD.</b> Tel Aviv 61570, Israel E-mail: neumo@neumo-vargus.co.il	<b>SL</b>	<b>Posredništvo HEIDENHAIN NAVO d.o.o.</b> 2000 Maribor, Slovenia www.heidenhain-hubl.si
<b>BE</b>	<b>HEIDENHAIN NV/SA</b> 1760 Roosdaal, Belgium www.heidenhain.be	<b>IN</b>	<b>HEIDENHAIN Optics &amp; Electronics India Private Limited</b> Chennai – 600 031, India www.heidenhain.in	<b>TH</b>	<b>HEIDENHAIN (THAILAND) LTD</b> Bangkok 10250, Thailand www.heidenhain.co.th
<b>BG</b>	<b>ESD Bulgaria Ltd.</b> Sofia 1172, Bulgaria www.esd.bg	<b>IT</b>	<b>HEIDENHAIN ITALIANA S.r.l.</b> 20128 Milano, Italy www.heidenhain.it	<b>TR</b>	<b>T&amp;M Mühendislik San. ve Tic. LTD. ŞTİ.</b> 34728 Ümraniye-Istanbul, Turkey www.heidenhain.com.tr
<b>BR</b>	<b>DIADUR Indústria e Comércio Ltda.</b> 04763-070 – São Paulo – SP, Brazil www.heidenhain.com.br	<b>JP</b>	<b>HEIDENHAIN K.K.</b> Tokyo 194-0215, Japan www.heidenhain.co.jp	<b>TW</b>	<b>HEIDENHAIN Co., Ltd.</b> Taichung 40768, Taiwan R.O.C. www.heidenhain.com.tw
<b>BY</b>	<b>Belarus GERTNER Service GmbH</b> 50354 Huert, Germany www.gertner.biz	<b>KR</b>	<b>HEIDENHAIN Korea LTD.</b> Gasam-Dong, Seoul, Korea 153-782 www.heidenhain.co.kr	<b>UA</b>	<b>Gertner Service GmbH Büro Kiev</b> 01133 Kiev, Ukraine www.gertner.biz
<b>CA</b>	<b>HEIDENHAIN CORPORATION</b> Mississauga, Ontario L5T2N2, Canada www.heidenhain.com	<b>ME</b>	Montenegro → <b>SL</b>	<b>US</b>	<b>HEIDENHAIN CORPORATION</b> Schaumburg, IL 60173-5337, USA www.heidenhain.com
<b>CH</b>	<b>HEIDENHAIN (SCHWEIZ) AG</b> 8603 Schwerzenbach, Switzerland www.heidenhain.ch	<b>MK</b>	Macedonia → <b>BG</b>	<b>VE</b>	<b>Maquinaria Diekmann S.A.</b> Caracas, 1040-A, Venezuela E-mail: purchase@diekmann.com.ve
<b>CN</b>	<b>DR. JOHANNES HEIDENHAIN (CHINA) Co., Ltd.</b> Beijing 101312, China www.heidenhain.com.cn	<b>MX</b>	<b>HEIDENHAIN CORPORATION MEXICO</b> 20235 Aguascalientes, Ags., Mexico E-mail: info@heidenhain.com	<b>VN</b>	<b>AMS Co. Ltd</b> HCM City, Vietnam E-mail: davidgoh@amsvn.com
<b>CZ</b>	<b>HEIDENHAIN s.r.o.</b> 102 00 Praha 10, Czech Republic www.heidenhain.cz	<b>MY</b>	<b>ISOSERVE Sdn. Bhd</b> 56100 Kuala Lumpur, Malaysia E-mail: isoserve@po.jaring.my	<b>ZA</b>	<b>MAFEMA SALES SERVICES C.C.</b> Midrand 1685, South Africa www.heidenhain.co.za
<b>DK</b>	<b>TPTEKNIK A/S</b> 2670 Greve, Denmark www.tp-gruppen.dk	<b>NL</b>	<b>HEIDENHAIN NEDERLAND B.V.</b> 6716 BM Ede, Netherlands www.heidenhain.nl		
		<b>NO</b>	<b>HEIDENHAIN Scandinavia AB</b> 7300 Orkanger, Norway www.heidenhain.no		

