



HEIDENHAIN



Angle Encoders
With Integral Bearing

April 2015

Representante oficial de:



HEIDENHAIN

[Argentina – Bolivia – Chile – Colombia - Costa Rica – Ecuador - El Salvador –
Guatemala – Honduras – Nicaragua – Panamá – Paraguay – Perú -
República Dominicana – Uruguay – Venezuela.]



Calle 49 N° 5764 - Villa Ballester (B1653AOX) - Prov. de Buenos Aires - ARGENTINA
Tel: (+54 11) 4768-4242 / Fax: (+54 11) 4849-1212
Mail: ventas@nakase.com.ar / Web: www.nakase.com.ar





Angle encoders with integral bearing and integrated stator coupling



Angle encoders with integral bearing for separate shaft coupling

Information on

- Angle encoders without integral bearing
- Magnetic modular encoders
- Rotary encoders
- Encoders for servo drives
- Exposed linear encoders
- Linear encoders for numerically controlled machine tools
- Interface electronics
- HEIDENHAIN controls

is available upon request as well as on the Internet at www.heidenhain.de.

Comprehensive descriptions of all available interfaces as well as general electrical information are included in the *Interfaces for HEIDENHAIN Encoders* catalog.

This catalog supersedes all previous editions, which thereby become invalid. The basis for ordering from HEIDENHAIN is always the catalog edition valid when the contract is made.

Standards (ISO, EN, etc.) apply only where explicitly stated in the catalog.

Contents

| Overview | | | | |
|---|--|----------------------|------------------------------|-----------|
| Angle encoders from HEIDENHAIN | | | 4 | |
| Selection guide | Absolute angle encoders with integral bearing | | 6 | |
| | Incremental angle encoders with integral bearing | | 8 | |
| | Angle encoders and modular encoders without integral bearing | | 10 | |
| Technical features and mounting information | | | | |
| Measuring principles | Measuring standard, Measuring principles, Photoelectric scanning | | 14 | |
| Measuring accuracy | | | 18 | |
| Mechanical design types and mounting | | | 20 | |
| General mechanical information | | | 26 | |
| Specifications | Series or model | System accuracy | | |
| Angle encoders with integral bearing and integrated stator coupling | RCN 2000 series | $\pm 5''/\pm 2.5''$ | 28 | |
| | RON 200 series | $\pm 5''/\pm 2.5''$ | 30 | |
| | RCN 5000 series | $\pm 5''/\pm 2.5''$ | 32 | |
| | RON 785 | $\pm 2''$ | 34 | |
| | RCN 8000 series | $\pm 2''/\pm 1''$ | $\varnothing 60 \text{ mm}$ | 36 |
| | | | $\varnothing 100 \text{ mm}$ | 38 |
| | RON 786 | $\pm 2''$ | 40 | |
| | RON 886/RPN 886 | $\pm 1''$ | | |
| | RON 905 | $\pm 0.4''$ | 42 | |
| Angle encoders with integral bearing and mounted stator coupling | ECN 200 | $\pm 10''$ | 44 | |
| Angle encoders with integral bearing for separate shaft coupling | ROD 200 series | $\pm 5''$ | 48 | |
| | ROD 780 ROD 880 | $\pm 2''$ | 50 | |
| | | $\pm 1''$ | | |
| Electrical connection | | | | |
| Interfaces and pin layouts | Incremental signals | $\sim 1 V_{PP}$ | 52 | |
| | | \square TTL | 53 | |
| | Absolute position values | EnDat | 54 | |
| | | FANUC and MITSUBISHI | 55 | |
| Cables and connecting elements | | | 56 | |
| Diagnostic and testing equipment | | | 60 | |
| Interface electronics | | | 62 | |

Angle encoders from HEIDENHAIN

The term angle encoder is typically used to describe encoders that have an accuracy of better than $\pm 5''$ and a line count above 10000.

Angle encoders are found in applications requiring precision angular measurement to accuracies within several arc seconds.

Examples:

- Rotary tables on machine tools
 - Swivel heads on machine tools
 - C-axes of lathes
 - Measuring machines for gears
 - Printing units of printing machines
 - Spectrometer
 - Telescopes
- etc.

In contrast, rotary encoders are used in applications where accuracy requirements are less stringent, e.g. in automation, electrical drives, and many other applications.

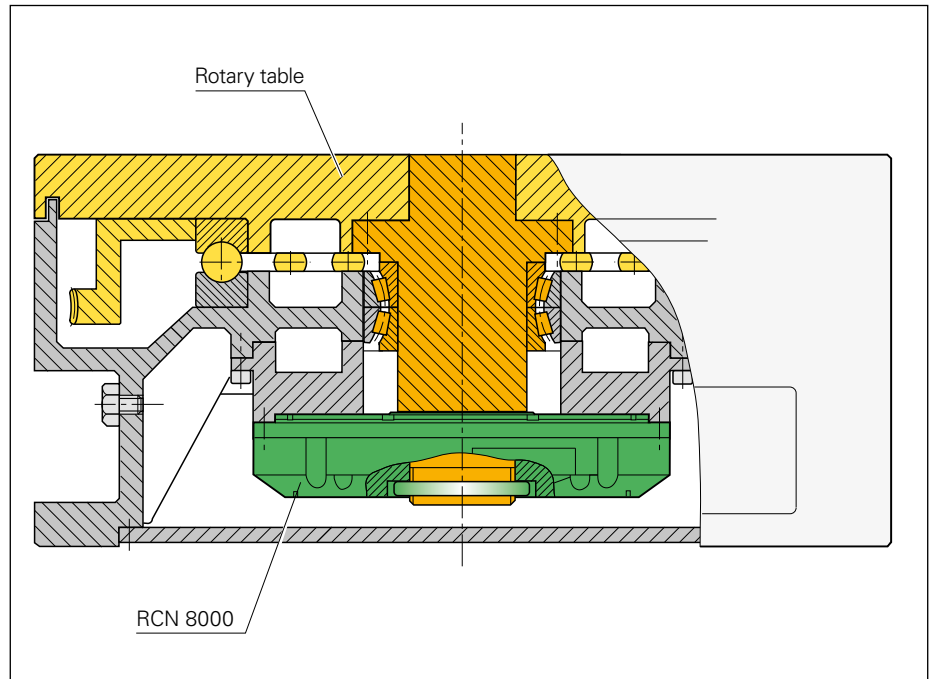

The **RCN 8000** angle encoder mounted on the rotary table of a machine tool

Angle encoders can have one of the following mechanical designs:

Angle encoders with integral bearing, hollow shaft and stator coupling

Because of the design and mounting of the stator coupling, it must absorb only that torque caused by friction in the bearing, particularly during angular acceleration of the shaft. These angle encoders therefore provide excellent dynamic performance. Thanks to the stator coupling, the system accuracy includes the error of the shaft coupling.

The **RCN**, **RON** and **RPN** angle encoders have an integrated stator coupling, whereas the **ECN** has a stator coupling mounted on the outside.

Other advantages:

- Compact size for limited installation space
- Hollow shaft diameters up to 100 mm to provide space for power lines, etc.
- Simple installation
- Versions with **functional safety** available on request

Selection guide

- For absolute angle encoders, see page 6/7
- For incremental angle encoders, see pages 8/9



RCN 8580 absolute angle encoder



ROD 880 incremental angle encoder with **K 16** flat coupling

Angle encoders with integral bearing, for separate shaft coupling

ROD angle encoders with solid shaft are particularly suited to applications where higher shaft speeds and/or larger mounting tolerances are required. The shaft couplings allow axial tolerances of up to ± 1 mm.

Selection guide on pages 8/9



ERA 4000 incremental angle encoder

Angle encoders without integral bearing

The **ERP**, **ERO** and **ERA** angle encoders without integral bearing (modular angle encoders) are intended for integration in machine elements or apparatuses. They are designed to meet the following requirements:

- Large hollow shaft diameters (up to 10 m with a scale tape)
- High shaft speeds up to 20000 min^{-1}
- No additional starting torque from shaft seals
- Segment versions

Selection guide on pages 10 to 13

Modular magnetic encoders

The robust **ERM** modular magnetic encoders are especially suited for use in production machines. The large inside diameters available, their small dimensions and the compact design of the scanning head predestine them for

- the C axis of lathes,
- simple rotary and tilting axes (e.g. for speed measurement on direct drives or for integration in gear stages),
- spindle orientation on milling machines or auxiliary axes.

Selection guide on pages 12/13

You can find more detailed information on our modular angle encoders on the Internet at www.heidenhain.de or in the *Angle Encoders without Integral Bearing* and *Modular Magnetic Encoders* catalogs.

Selection guide

Absolute angle encoders with integral bearing

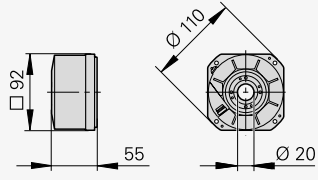
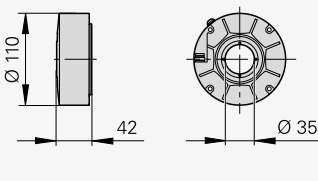
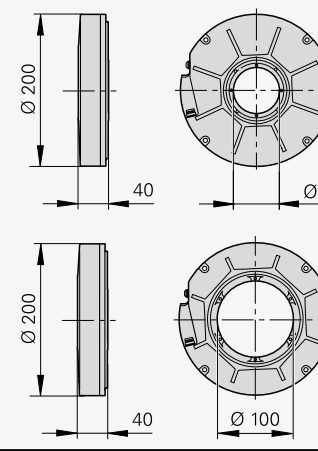
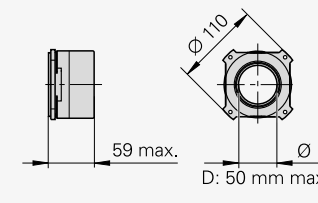
| Series | Overall dimensions in mm | System accuracy | Mechanically perm. speed | Position values/ Revolution | Interface | |
|--|---|--------------------|-----------------------------|--------------------------------|-----------------------|-----------|
| With integrated stator coupling | | | | | | |
| RCN 2000 |  | ± 5" | ≤ 1500 min ⁻¹ | 67 108 864 ± 26 bits | EnDat 2.2 | |
| | | ± 2.5" | | | 268 435 456 ± 28 bits | EnDat 2.2 |
| | | | | | | Fanuc αi |
| | | Mitsubishi | | | | |
| | | EnDat 2.2 | | | | |
| | | Fanuc αi | | | | |
| Mitsubishi | | | | | | |
| RCN 5000 |  | ± 5" | ≤ 1500 min ⁻¹ | 67 108 864 ± 26 bits | EnDat 2.2 | |
| | | ± 2.5" | | | 268 435 456 ± 28 bits | EnDat 2.2 |
| | | | | | | Fanuc αi |
| | | Mitsubishi | | | | |
| | | EnDat 2.2 | | | | |
| | | Fanuc αi | | | | |
| Mitsubishi | | | | | | |
| RCN 8000 |  | ± 2" | ≤ 500 min ⁻¹ | 536 870 912 ± 29 bits | EnDat 2.2 | |
| | | ± 1" | | | 536 870 912 ± 29 bits | EnDat 2.2 |
| | | | | | | Fanuc αi |
| | | Mitsubishi | | | | |
| | | EnDat 2.2 | | | | |
| | | EnDat 2.2 | | | | |
| Mitsubishi | | | | | | |
| With mounted stator coupling | | | | | | |
| ECN 200 |  | ± 10" | ≤ 3000 min ⁻¹ | 33 554 432 ± 25 bits | EnDat 2.2 | |
| | | | | | EnDat 2.2 | |
| | | | | 83 886 08 ± 23 bits | Fanuc α | |
| | | | | | Mitsubishi | |

¹⁾ **Functional safety** upon request

| | Incremental signals | Signal periods/ revolution | Model | Page |
|--|---------------------|-------------------------------|------------|-----------|
| | ~ 1 V _{PP} | 16384 | RCN 2380 | 28 |
| | - | - | RCN 2310 | |
| | - | - | RCN 2390 F | |
| | - | - | RCN 2390 M | |
| | ~ 1 V _{PP} | 16384 | RCN 2580 | |
| | - | - | RCN 2510 | |
| | - | - | RCN 2590 F | |
| | - | - | RCN 2590 M | |
| | ~ 1 V _{PP} | 16384 | RCN 5380 | 32 |
| | - | - | RCN 5310 | |
| | - | - | RCN 5390 F | |
| | - | - | RCN 5390 M | |
| | ~ 1 V _{PP} | 16384 | RCN 5580 | |
| | - | - | RCN 5510 | |
| | - | - | RCN 5590 F | |
| | - | - | RCN 5590 M | |
| | ~ 1 V _{PP} | 32768 | RCN 8380 | 36 |
| | - | - | RCN 8310 | |
| | - | - | RCN 8390 F | |
| | - | - | RCN 8390 M | |
| | ~ 1 V _{PP} | 32768 | RCN 8580 | 38 |
| | - | - | RCN 8510 | |
| | - | - | RCN 8590 F | |
| | - | - | RCN 8590 M | |
| | ~ 1 V _{PP} | 2048 | ECN 225 | 44 |
| | - | - | ECN 225 | |
| | - | - | ECN 223 F | |
| | - | - | ECN 223 M | |



RCN 2000



RCN 5000



RCN 8000
Ø 60 mm



RCN 8000
Ø 100 mm



ECN 200
Ø 50 mm

Selection guide

Incremental angle encoders with integral bearing

| Series | Overall dimensions in mm | System accuracy | Mechanically permissible speed ¹⁾ | Interface |
|--|-----------------------------|-----------------|---|-----------------------|
| With integrated stator coupling | | | | |
| RON 200 | | ± 5" | ≤ 3000 min ⁻¹ | □ TTL |
| | | ± 2.5" | | □ TTL |
| RON 700 | | ± 2" | ≤ 1000 min ⁻¹ | ~ 1 V _{PP} |
| | | | | ~ 1 V _{PP} |
| RON 800 RPN 800 | | ± 1" | ≤ 1000 min ⁻¹ | ~ 1 V _{PP} |
| RON 900 | | ± 0.4" | ≤ 100 min ⁻¹ | ~ 11 μA _{PP} |
| For separate shaft coupling | | | | |
| ROD 200 | | ± 5" | ≤ 10000 min ⁻¹ | □ TTL |
| | | | | □ TTL |
| | | | | ~ 1 V _{PP} |
| ROD 700 | | ± 2" | ≤ 1000 min ⁻¹ | ~ 1 V _{PP} |
| ROD 800 | | ± 1" | ≤ 1000 min ⁻¹ | ~ 1 V _{PP} |

¹⁾ May be limited in operation by electrically permissible shaft speed

²⁾ After integrated interpolation

| | Signal periods/ revolution | Model | Page |
|--|-------------------------------|---------|------|
| | 18000 ²⁾ | RON 225 | 30 |
| | 180000/90000 ²⁾ | RON 275 | |
| | 18000 | RON 285 | |
| | 18000 | RON 287 | |
| | 18000 | RON 785 | 34 |
| | 18000/36000 | RON 786 | 40 |
| | 36000 | RON 886 | |
| | 180000 | RPN 886 | |
| | 36000 | RON 905 | 42 |
| | 18000 ²⁾ | ROD 220 | 48 |
| | 180000 ²⁾ | ROD 270 | |
| | 18000 | ROD 280 | |
| | 18000/36000 | ROD 780 | 50 |
| | 36000 | ROD 880 | |



RON 285



RON 786



RON 905



ROD 280



ROD 780

Selection guide

Angle encoders without integral bearing

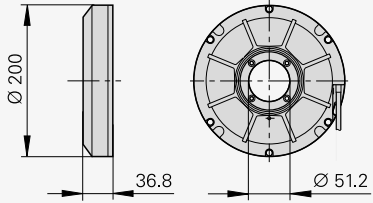
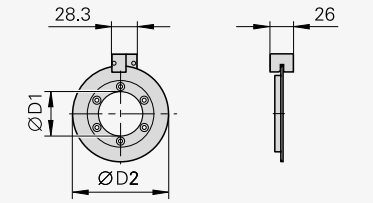
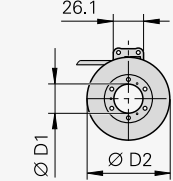
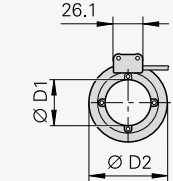
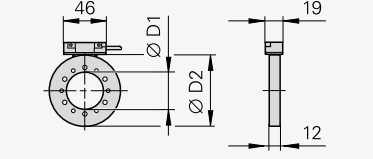
| Series | Version and mounting | Overall dimensions in mm | Diameter D1/D2 | Accuracy of graduation | Mechanically permissible speed ¹⁾ |
|---|---|---|--|---------------------------|--|
| Angle encoders with graduation on glass disk | | | | | |
| ERP 880 | Phase grating on glass disk with hub; screwed onto front of shaft |  | – | ± 0.9" | ≤ 1000 min ⁻¹ |
| ERP 4000 | Phase grating on glass disk with hub; screwed onto front of shaft |  | D1: 8 mm D2: 44 mm | ± 2" | ≤ 300 min ⁻¹ |
| ERP 8000 | | | D1: 50 mm D2: 108 mm | ± 1" | ≤ 100 min ⁻¹ |
| ERO 6000 | METALLUR graduation on glass disk with hub; screwed onto front of shaft |  | D1: 25/95 mm D2: 71/150 mm | ± 3" / ± 2" | ≤ 1600 min ⁻¹ ≤ 800 min ⁻¹ |
| ERO 6100 | Chrome graduation on glass; screwed onto front of shaft |  | D1: 41 mm D2: 70 mm | ± 10" | ≤ 3500 min ⁻¹ |
| Angle encoders with graduation on steel scale drum | | | | | |
| ECA 4000 | Scale drum with centering collar; screwed onto front of shaft |  | D1: 70 mm to 512 mm D2: 104.3 mm to 560.46 mm | ± 3" to ± 1.5" | ≤ 8500 min ⁻¹ to ≤ 1500 min ⁻¹ |
| ERA 4x80 | | | D1: 40 mm to 512 mm D2: 76.5 mm to 560.46 mm | ± 5" to ± 2" | ≤ 10000 min ⁻¹ to ≤ 1500 min ⁻¹ |
| ERA 4282 | Scale drum for increased accuracy; screwed onto front of shaft | | D1: 40 mm to 270 mm D2: 76.5 mm to 331.31 mm | ± 4" to ± 1.7" | ≤ 10000 min ⁻¹ to ≤ 2500 min ⁻¹ |

¹⁾ May be limited in operation by electrically permissible shaft speed

²⁾ After integrated interpolation

| | Interface | Signal periods/rev | Reference marks | Model | Further Information |
|--|---------------------|----------------------------------|-----------------|------------------|--|
| | ~ 1 V _{PP} | 180000 | One | ERP 880 | Catalog: <i>Angle Encoders Without Integral Bearing</i> |
| | ~ 1 V _{PP} | 131072 | No | ERP 4080 | |
| | ~ 1 V _{PP} | 360000 | No | ERP 8080 | |
| | ~ 1 V _{PP} | 9000/ 18000 | One | ERO 6080 | |
| | □ TTL | 45000 to 900000 ²⁾ | One | ERO 6070 | |
| | ~ 1 V _{PP} | 4096 | One | ERO 6180 | |
| | EnDat 2.2 | – | – | ECA 4410 | Product Info <i>ECA 4000</i> |
| | Fanuc | | | ECA 4490F | |
| | Mitsubishi | | | ECA 4490M | |
| | ~ 1 V _{PP} | 12000 to 52000 | Distance-coded | ERA 4280C | Catalog: <i>Angle Encoders Without Integral Bearing</i> |
| | | 6000 to 44000 | | ERA 4480C | |
| | | 3000 to 13000 | | ERA 4880C | |
| | ~ 1 V _{PP} | 12000 to 52000 | Distance-coded | ERA 4282C | |



ERP 880



ERP 4080



ERO 6080



ERA 4000

Selection guide

Angle encoders without integral bearing and modular encoders

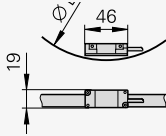
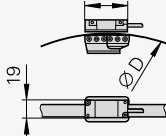
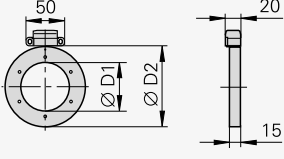
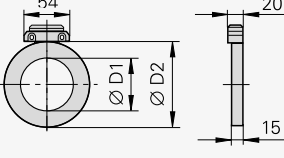
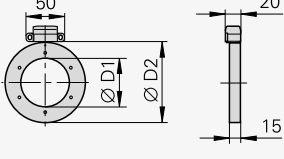
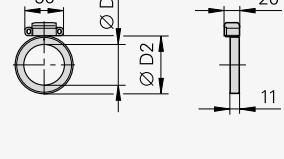
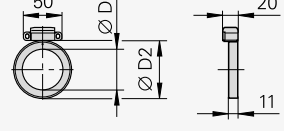
| Series | Version and mounting | Overall dimensions in mm | Diameter | Accuracy of graduation | Mechanically permissible speed ²⁾ |
|---|---|---|---|---------------------------|---|
| Angle encoders with graduation on steel tape | | | | | |
| ERA 7000 | Steel scale tape for internal mounting, full circle version ¹⁾ ; scale tape is tensioned on the inside circumference |  | 458.62 mm to 1 146.10 mm | ± 3.9" to ± 1.6" | ≤ 250 min ⁻¹ to ≤ 220 min ⁻¹ |
| ERA 8000 | Steel scale tape for external mounting, full circle version; scale tape is tensioned on the outside circumference |  | 458.11 mm to 1 145.73 mm | ± 4.7" to ± 1.9" | ≈ ≤ 45 min ⁻¹ |
| Modular encoders with magnetic graduation | | | | | |
| ERM 2200 | Steel scale drum with MAGNODUR graduation; fastened by axial screws |  | D1: 70 mm to 380 mm D2: 113.16 mm to 452.64 mm | ± 7" to ± 2.5" | ≤ 14500 min ⁻¹ to ≤ 3000 min ⁻¹ |
| ERM 200 | Steel scale drum with MAGNODUR graduation; fastened by axial screws |  | D1: 40 mm to 410 mm D2: 75.44 mm to 452.64 mm | ± 11" to ± 3.5" | ≤ 19000 min ⁻¹ to ≤ 3000 min ⁻¹ |
| ERM 2410 | Steel scale drum with MAGNODUR graduation; fastened by axial screws |  | D1: 40 mm to 410 mm D2: 75.44 mm to 452.64 mm | ± 11" to ± 3.5" | ≤ 19000 min ⁻¹ to ≤ 3000 min ⁻¹ |
| ERM 2400 | Steel scale drum with MAGNODUR graduation; friction-locked fastening by clamping the drum |  | D1: 40 mm to 100 mm D2: 64.37 mm to 128.75 mm | ± 17" to ± 9" | 42000 min ⁻¹ to 20000 min ⁻¹ |
| | Steel scale drum with MAGNODUR graduation; friction-locked fastening by clamping the drum; additional slot for feather key as anti-rotation element | | D1: 40 mm; 55 mm D2: 64.37 mm; 75.44 mm | | ≤ 33000 min ⁻¹ ; ≤ 27000 min ⁻¹ |
| ERM 2900 | Steel scale drum with MAGNODUR graduation; friction-locked fastening by clamping the drum |  | D1: 40 mm to 100 mm D2: 58.06 to 120.96 mm | ± 68" to ± 33" | ≤ 47000 min ⁻¹ to ≤ 16000 min ⁻¹ |

1) Segment versions upon request

2) May be limited in operation by electrically permissible shaft speed

3) The position value is generated internally from the incremental signals after traverse over two reference marks.

| | Interface | Signal periods/rev | Reference marks | Model | Further information |
|--|-------------------------|--------------------|-----------------------|------------------|---|
| | ~ 1 V _{PP} | 36000 to 90000 | Distance-coded | ERA 7480C | Catalog: <i>Angle Encoders Without Integral Bearing</i> |
| | ~ 1 V _{PP} | 36000 to 90000 | Distance-coded | ERA 8480C | |
| | ~ 1 V _{PP} | 1800 to 7200 | Distance-coded | ERM 2280 | Catalog: <i>Magnetic Modular Encoders</i> |
| | □ TTL | 600 to 3600 | One or distance-coded | ERM 220 | |
| | ~ 1 V _{PP} | | | ERM 280 | |
| | EnDat 2.2 ³⁾ | 600 to 3600 | Distance-coded | ERM 2410 | |
| | ~ 1 V _{PP} | 512 to 1024 | One | ERM 2484 | |
| | ~ 1 V _{PP} | 512; 600 | | ERM 2485 | |
| | ~ 1 V _{PP} | 192 to 400 | One | ERM 2984 | |



ERA 7480



ERA 8480



ERM 2200
ERM 2410



ERM 200



ERM 2400



ERM 2900

Measuring principles

Measuring standard

HEIDENHAIN encoders with optical scanning incorporate measuring standards of periodic structures known as graduations.

These graduations are applied to a carrier substrate of glass or steel. The scale substrate for large measuring lengths is a steel tape.

HEIDENHAIN manufactures the precision graduations in specially developed, photolithographic processes.

- AURODUR: matte-etched lines on gold-plated steel tape with typical graduation period of 40 μm
- METALLUR: contamination-tolerant graduation of metal lines on gold, with typical graduation period of 20 μm
- DIADUR: extremely robust chromium lines on glass (typical graduation period of 20 μm) or three-dimensional chromium structures (typical graduation period of 8 μm) on glass
- SUPRADUR phase grating: optically three dimensional, planar structure; particularly tolerant to contamination; typical graduation period of 8 μm and finer
- OPTODUR phase grating: optically three dimensional, planar structure with particularly high reflectance, typical graduation period of 2 μm and less

Along with these very fine grating periods, these processes permit a high definition and homogeneity of the line edges. Together with the photoelectric scanning method, this high edge definition is a precondition for the high quality of the output signals.

The master graduations are manufactured by HEIDENHAIN on custom-built high-precision dividing engines.

Absolute measuring method

With the absolute measuring method, the position value is available from the encoder immediately upon switch-on and can be called at any time by the subsequent electronics. There is no need to move the axes to find the reference position.

The absolute position information is read from the **graduated disk** which is formed from a serial absolute code structure. The code structure is unique over one revolution. A separate incremental track is read with the single-field scanning principle and interpolated for the position value.

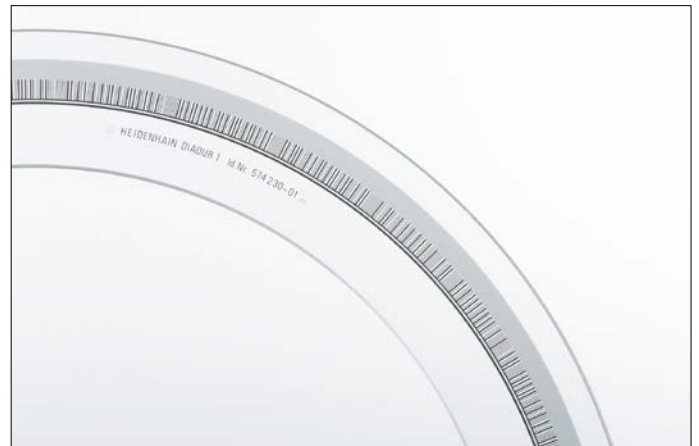

Graduated disk with serial absolute code track and incremental track

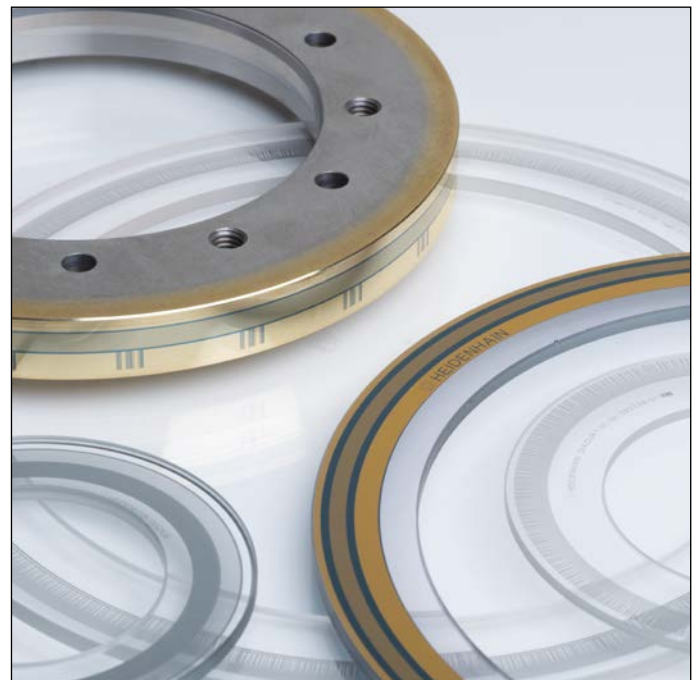

Absolute and incremental circular scales and scale drums

Incremental measuring method

With the incremental measuring method, the graduation consists of a periodic grating structure. The position information is obtained **by counting** the individual increments (measuring steps) from some point of origin. Since an absolute reference is required to ascertain positions, the scales or scale tapes are provided with an additional track that bears a **reference mark**. The absolute position on the scale, established by the reference mark, is gated with exactly one measuring step.

The reference mark must therefore be scanned to establish an absolute reference or to find the last selected datum.

In some cases, this may require rotation by up to nearly 360°. To speed and simplify such "reference runs," many HEIDENHAIN encoders feature **distance-coded reference marks**—multiple reference marks that are individually spaced according to a mathematical algorithm. The subsequent electronics find the absolute reference after traversing two successive reference marks—meaning only a few degrees of traverse (see nominal increment I in the table).

Encoders with distance-coded reference marks are identified with a "C" behind the model designation (e.g. RON 786C).

With distance-coded reference marks, the **absolute reference** is calculated by counting the signal periods between two reference marks and using the following formulas:

$$\alpha_1 = (\text{abs } A - \text{sgn } A - 1) \times \frac{G}{2} + (\text{sgn } A - \text{sgn } D) \times \frac{\text{abs } M_{RR}}{2}$$

where:

$$A = \frac{2 \times \text{abs } M_{RR} - G}{GP}$$

Where:

α_1 = Absolute angular position of the first traversed reference mark to the zero position in degrees

abs = Absolute value

sgn = Sign function (" +1 " or " -1 ")

M_{RR} = Measured distance between the traversed reference marks in degrees

I = Nominal increment between two fixed reference marks (see table)

GP = Grating period ($\frac{360^\circ}{\text{Line count}}$)

D = Direction of rotation (+1 or -1)
Rotation to the right (when viewing the mounting side of the angle encoder—see "Mating dimensions") results in "+1"

| Line count z | Number of reference marks | Nominal increment I |
|--------------|---------------------------|---------------------|
| 36000 | 72 | 10° |
| 18000 | 36 | 20° |

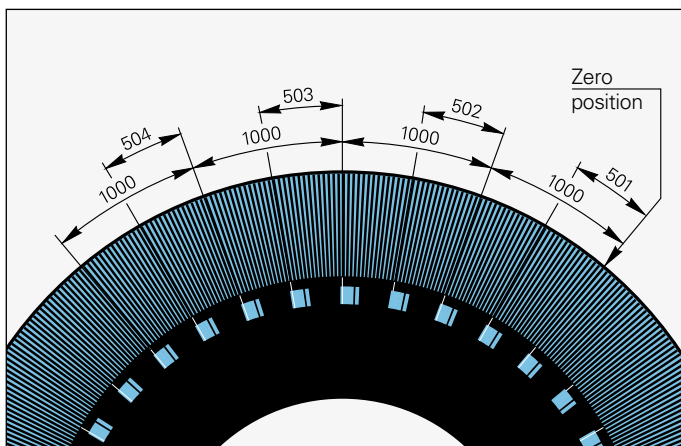

Schematic representation of a circular scale with distance-coded reference marks

Photoelectric scanning

Most HEIDENHAIN encoders operate using the principle of photoelectric scanning. Photoelectric scanning of a measuring standard is contact-free, and as such, free of wear. This method detects even very fine lines, no more than a few micrometers wide, and generates output signals with very small signal periods.

The finer the grating period of a measuring standard is, the greater the effect of diffraction on photoelectric scanning. HEIDENHAIN uses two scanning principles with angle encoders:

- The **imaging scanning principle** for grating periods from 10 μm to approx. 70 μm .
- The **interferential scanning principle** for very fine graduations with grating periods of 4 μm .

Imaging principle

Put simply, the imaging scanning principle functions by means of projected-light signal generation: two graduations with equal grating periods—the circular scale and the scanning reticle—are moved relative to each other. The carrier material of the scanning reticle is transparent, whereas the graduation on the measuring standard may be applied to a transparent or reflective surface.

When parallel light passes through a grating, light and dark surfaces are projected at a certain distance. An index grating with the same grating period is located here. When the two gratings move relative to each other, the incident light is modulated. If the gaps in the gratings are aligned, light passes through. If the lines of one grating coincide with the gaps of the other, no light passes through.

Photovoltaic cells or a large-surface photovoltaic-cell array convert these variations in light intensity into electrical signals. The specially structured grating of the scanning reticle filters the light to generate nearly sinusoidal output signals. The smaller the period of the grating structure is, the closer and more tightly tolerated the gap must be between the scanning reticle and circular scale. Practical mounting tolerances for encoders with the imaging scanning principle are achieved with grating periods of 10 μm and larger.

The RCN, ECN, RON and ROD angle encoders with integral bearing operate according to the imaging scanning principle.

Imaging principle

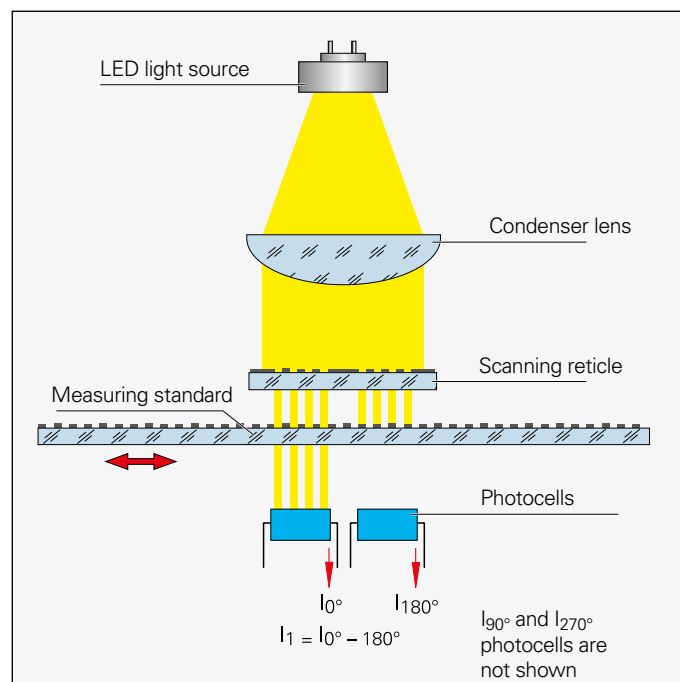

Interferential scanning principle

The interferential scanning principle exploits the diffraction and interference of light on a fine graduation to produce signals used to measure displacement.

A step grating is used as the measuring standard: reflective lines 0.2 μm high are applied to a flat, reflective surface. In front of that is the scanning reticle—a transparent phase grating with the same grating period as the scale.

When a light wave passes through the scanning reticle, it is diffracted into three partial waves of the orders -1, 0, and +1, with approximately equal luminous intensity. The waves are diffracted by the scale such that most of the luminous intensity is found in the reflected diffraction orders +1 and -1. These partial waves meet again at the phase grating of the scanning reticle where they are diffracted again and interfere. This produces essentially three waves that leave the scanning reticle at different angles. Photovoltaic cells convert this alternating light intensity into electrical signals.

A relative motion of the scanning reticle to the scale causes the diffracted wave fronts to undergo a phase shift: when the grating moves by one period, the wave front of the first order is displaced by one wavelength in the positive direction, and the wavelength of diffraction order -1 is displaced by one wavelength in the negative direction. Since the two waves interfere with each other when exiting the grating, the waves are shifted relative to each other by two wavelengths. This results in two signal periods from the relative motion of just one grating period.

Interferential encoders function with average grating periods of 4 μm and finer. Their scanning signals are largely free of harmonics and can be highly interpolated. These encoders are therefore especially suited for high resolution and high accuracy. Even so, their generous mounting tolerances permit installation in a wide range of applications.

The RPN 886 angle encoder with integral bearing operates according to the interferential scanning principle.

Interferential scanning principle (optics schematics)

C Grating period

Ψ Phase shift of the light wave when passing through the scanning reticle

Ω Phase shift of the light wave due to motion X of the scale

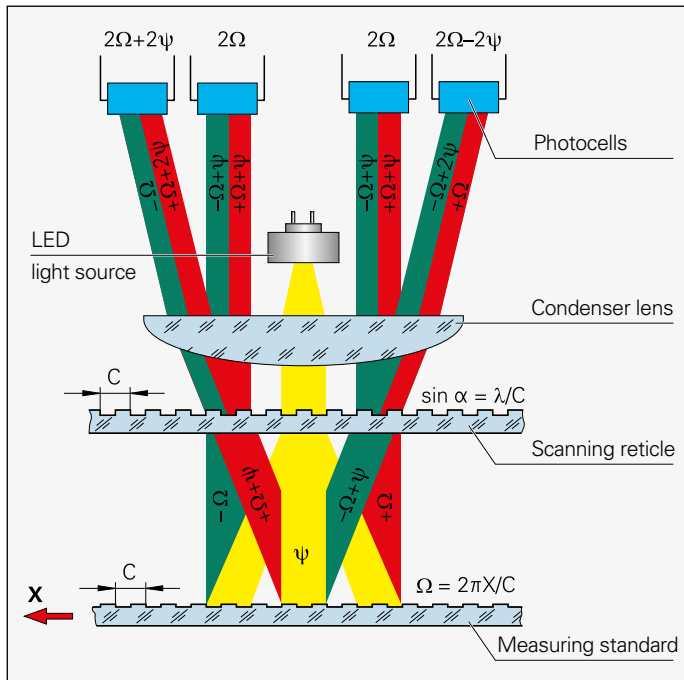

Measuring accuracy

The accuracy of angular measurement is mainly determined by

- the quality of the graduation,
- the quality of the scanning process,
- the quality of the signal processing electronics,
- the eccentricity of the graduation to the bearing,
- the error of the bearing,
- the coupling to the measured shaft, and
- the elasticity of the stator coupling (RCN, ECN, RON, RPN) or shaft coupling (ROD)

These factors of influence are comprised of encoder-specific error and application-dependent issues. All individual factors of influence must be considered in order to assess the attainable **overall accuracy**.

Error specific to the measuring device

For angle encoders with integral bearing, the error that is specific to the measuring device is shown in the Specifications as the **system accuracy**.

The extreme values of the total deviations of a position are—referenced to their mean value—within the system accuracy $\pm a$.

The system accuracy reflects position errors within one revolution as well as those within one signal period and—for angle encoders with stator coupling—the errors of the shaft coupling.

Position error within one signal period

Position errors within one signal period are considered separately, since they already have an effect even in very small angular motions and in repeated measurements. They especially lead to speed ripples in the speed control loop.

The position error within one signal period $\pm u$ results from the quality of the scanning and—for encoders with integrated pulse-shaping or counter electronics—the quality of the signal-processing electronics. For encoders with sinusoidal output signals, however, the errors of the signal processing electronics are determined by the subsequent electronics.

The following individual factors influence the result:

- The size of the signal period
- The homogeneity and period definition of the graduation
- The quality of scanning filter structures
- The characteristics of the sensors
- The stability and dynamics of further processing of the analog signals

These errors are considered when specifying the position error within one signal period.

The position error within one signal period $\pm u$ is indicated in the specifications of the angle encoders.

As the result of increased reproducibility of a position, much smaller measuring steps are still useful.

Application-dependent error

For **angle encoders with integral bearing** the specified system accuracy already includes the error of the bearing. For angle encoders with separate **shaft coupling (ROD)**, the angle error of the coupling must be added (see *Mechanical design types and mounting — ROD*). For angle encoders with **stator coupling (RCN, ECN, ROP, RPN)**, the system accuracy already includes the error of the shaft coupling.

In contrast, the mounting and adjustment of the scanning head normally have a significant effect on the accuracy that can be achieved by **encoders without integral bearing**. Of particular importance are the mounting eccentricity of the graduation and the radial runout of the measured shaft. The application-dependent error values must be measured and calculated individually in order to evaluate the **overall accuracy** of such encoders (see the *Angle Encoders without Integral Bearing* catalog).

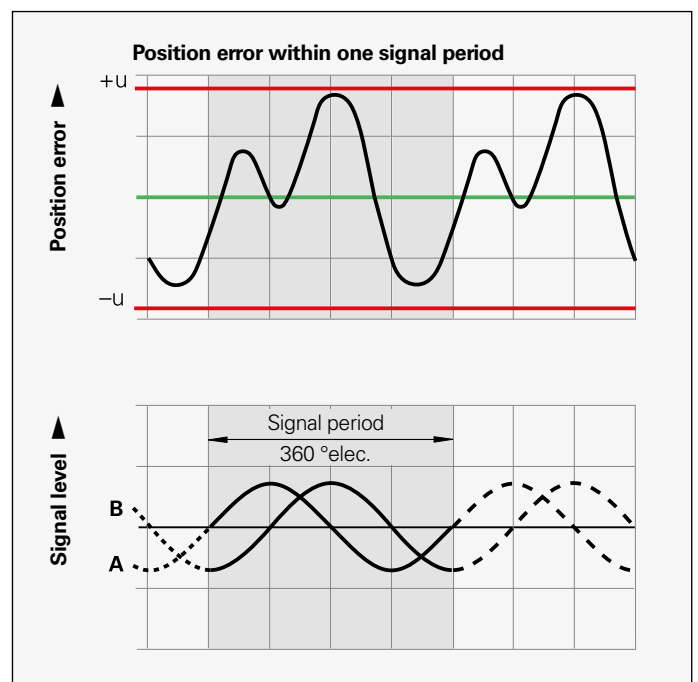
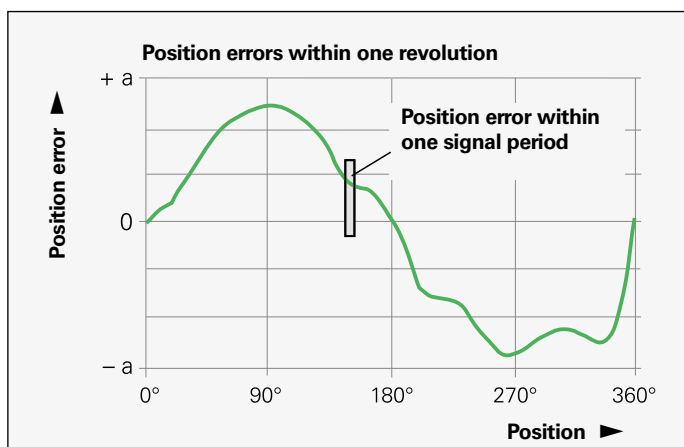

Calibration chart

For its angle encoders with integral bearings, HEIDENHAIN prepares individual Quality Inspection Certificates and ships them with the encoder.

The **Quality Inspection Certificate** documents the system accuracy. It is ascertained through five forward and five backward measurements. The measuring positions per revolution are chosen to determine very exactly not only the long-range error, but also the position error within one signal period.

The **mean value curve** shows the arithmetic mean of the measured values, in which the mechanical hysteresis is not included.

The **mechanical hysteresis** depends on the shaft coupling. On angle encoders with stator coupling—RCN, ECN, RPN and RPN—it is determined at ten measuring positions in forward and backward steps. The maximum value and arithmetic mean are documented on the calibration chart.

The following limits apply to the mechanical hysteresis:

- RCN 2xxx/RON 2xx:** $\leq 0.6''$
- RCN 5xxx:** $\leq 0.6''$
- ECN 2xx:** $\leq 2''$
- RON 7xx:** $\leq 0.4''$
- RCN 8xxx/RON/RPN 8xx:** $\leq 0.4''$

The **calibration standard** indicated in the Quality Inspection Certificate documents and guarantees traceability to recognized national and international standards.

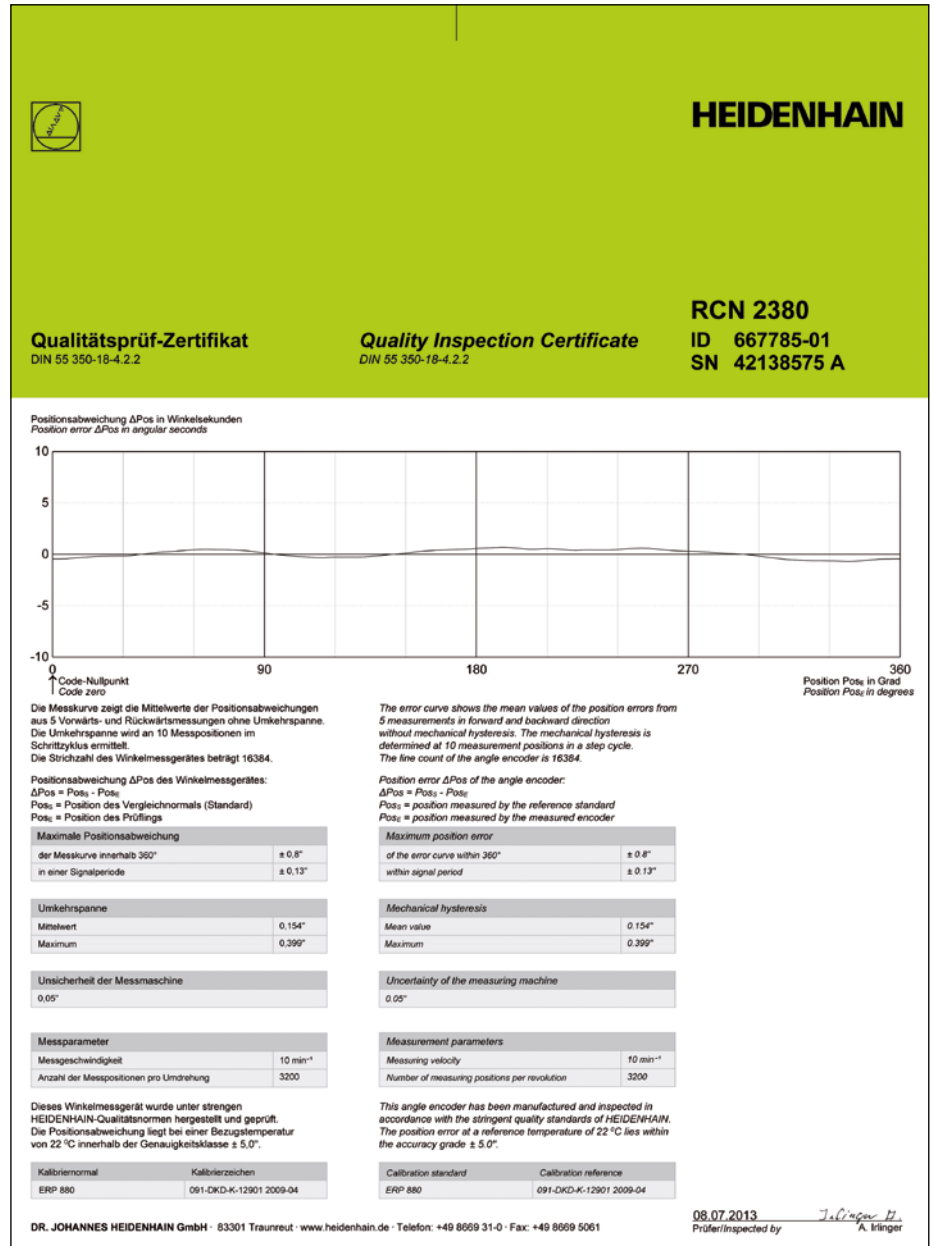

Example

Determination of the reversal error with forward and backward measurements

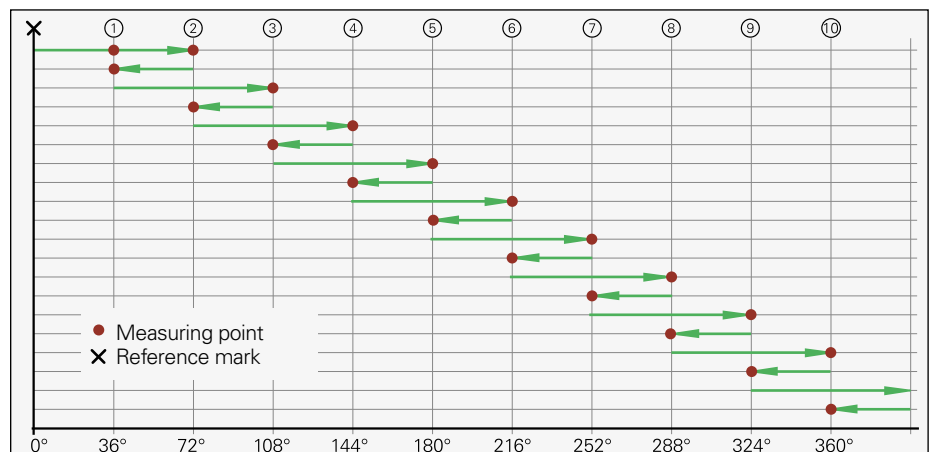

Mechanical design types and mounting

RCN, ECN, RON, RPN

RCN, ECN, RON and RPN angle encoders have an integral bearing, hollow shaft and a coupling on the stator side. The measured shaft is directly connected with the shaft of the angle encoder.

Setup

The graduated disk is rigidly affixed to the hollow shaft. The scanning unit rides on the shaft on ball bearings and is connected to the housing with a coupling on the stator side. The stator coupling and the sealing design greatly compensate axial and radial mounting errors without restricting function or accuracy. This permits relatively large mounting tolerances to facilitate mounting, especially for the RCN. Particularly during angular acceleration of the shaft, the coupling must absorb only that torque caused by friction in the bearing. Angle encoders with stator coupling therefore provide excellent dynamic performance.

Mounting

The housing of the RCN, ECN, RON, and RPN is firmly connected by an integral mounting flange and a centering collar to the stationary machine part.

- **Shaft coupling for RCN, ECN (Ø 20 mm), RON, RPN**

Shaft coupling with ring nut

The shaft is a hollow through shaft. For installation, the hollow through shaft of the angle encoder is placed over the machine shaft, and is fixed with a ring nut from the front of the encoder. The ring nut can easily be tightened with the mounting aid.

Front-end shaft coupling

It is often helpful, especially with rotary tables, to integrate the angle encoder in the table so that it is freely accessible when the rotor is lifted off. The hollow shaft is connected by threaded holes on the front end with the aid of special mounting elements adapted to the respective design (not included in delivery). To comply with radial and axial runout specifications, the internal bore ① and the shoulder surface ② are to be used as mounting surfaces for shaft coupling at the front of the encoder.

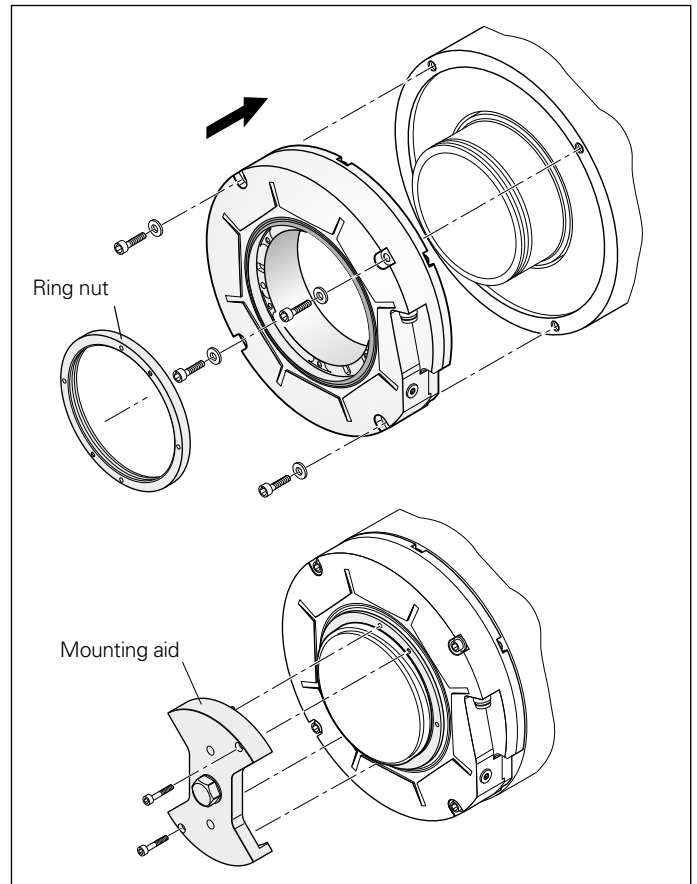

Mounting an angle encoder with a ring nut

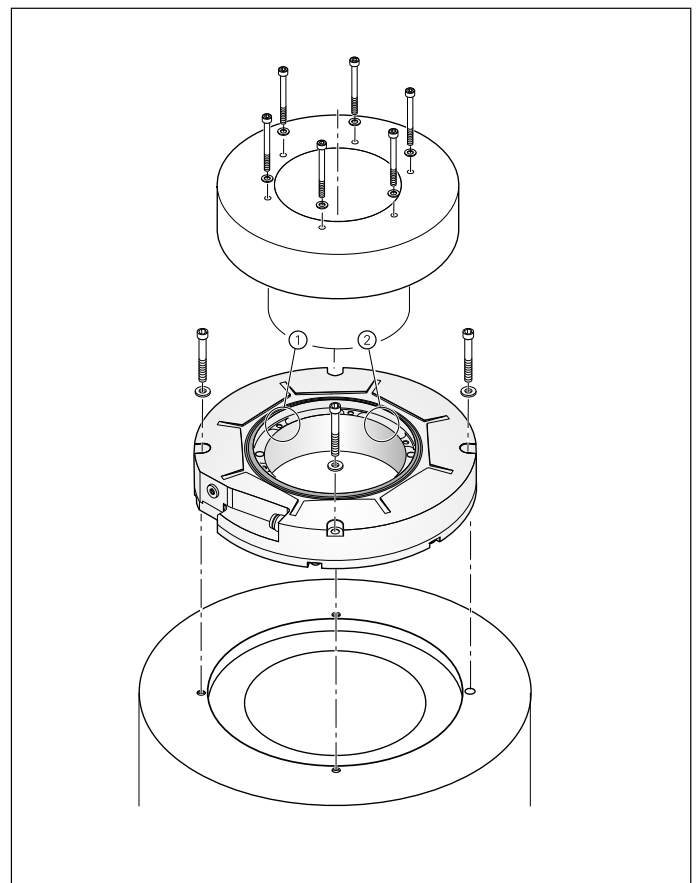

Example of connecting an encoder to the shaft face

Mechanical fault exclusion

For the RCN 2000, RCN 5000 and RCN 8000, a fault exclusion can be realized for the loosening of the mechanical connection between the encoder and drive. For this purpose, the shaft has to be coupled either through an additional catch or additional spring pins. At the same time there are constraints and changes in

- the maximum permissible shaft speed,
- the operating temperature,
- the permissible angular acceleration, and
- the materials to be used.

For more details, refer to the Product Information documents "RCN 2000, RCN 5000, RCN 8000 – Absolute Angle Encoders for Safety-Related Applications."

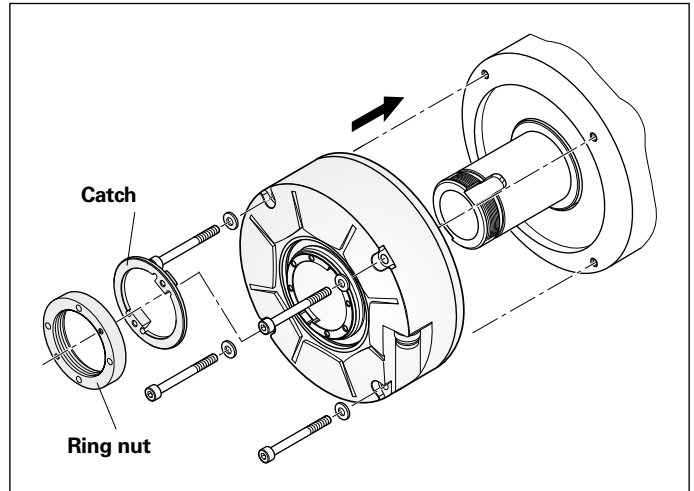

Shaft coupling with ring nut and catch

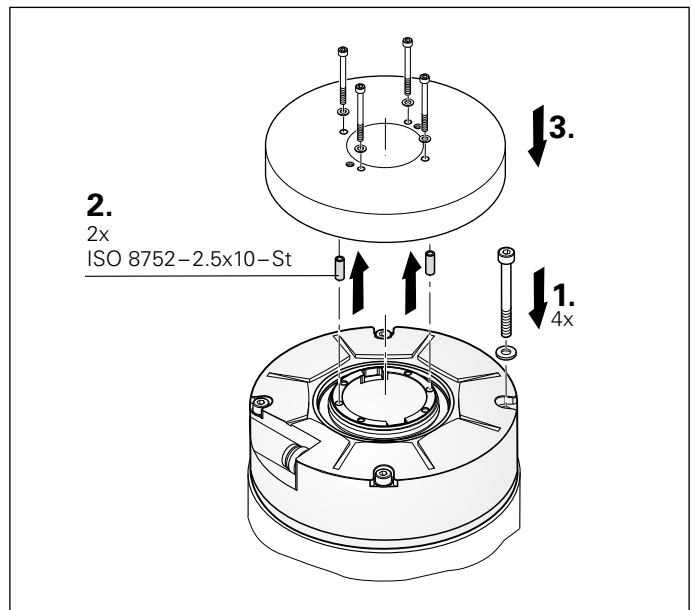

Front-end shaft coupling with mounting screws and spring pins

Catch for mechanical fault exclusion of the shaft coupling through ring nut on the RCN

- Catch for RCN 2000: ID 817921-01
- Catch for RCN 5000: ID 817921-02
- Catch for RCN 8000:
 - Hollow shaft Ø 60 mm: ID 817921-03
 - Hollow shaft Ø 100 mm: ID 817921-04

| | Moment of inertia of ring nut and catch |
|---------------------|---|
| RCN 2000 | $4.8 \cdot 10^{-6} \text{ kgm}^2$ |
| RCN 5000 | $24 \cdot 10^{-6} \text{ kgm}^2$ |
| RCN 8000 (Ø 60 mm) | $87 \cdot 10^{-6} \text{ kgm}^2$ |
| RCN 8000 (Ø 100 mm) | $550 \cdot 10^{-6} \text{ kgm}^2$ |

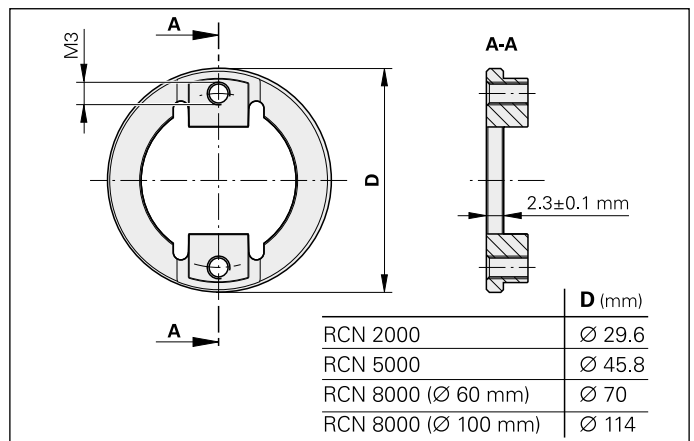

- **Shaft coupling for ECN (Ø 50 mm)**

The ECN 200 is slid by its hollow shaft onto the measured shaft, and the rotor is fastened by three eccentric clamps.

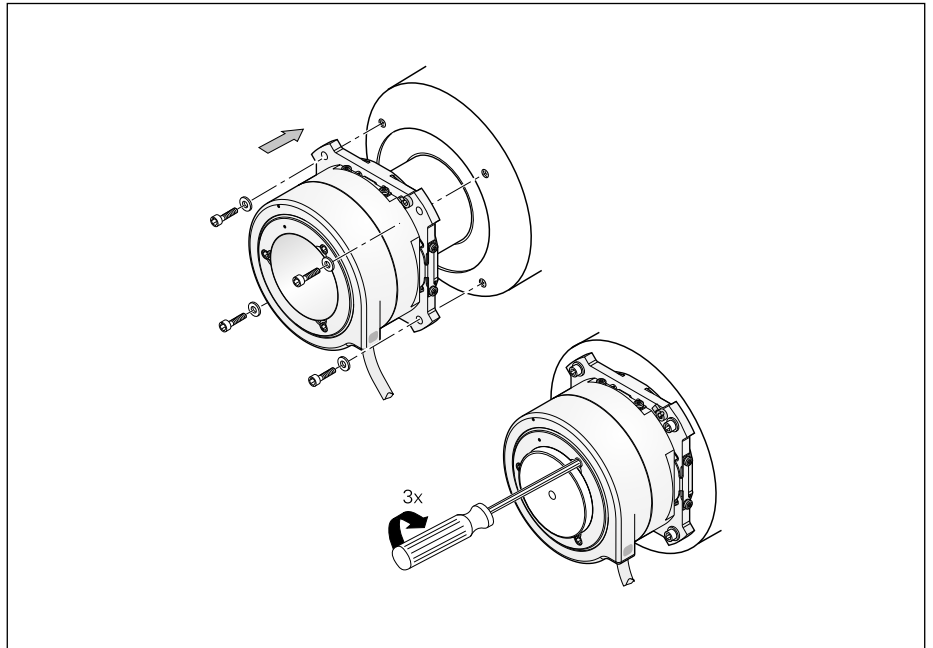

Mounting an ECN 200 with Ø 50 mm hollow shaft

- **Shaft coupling for RON 905**

The RON 905 has a blind hollow shaft. The shaft is connected by an axial central screw.

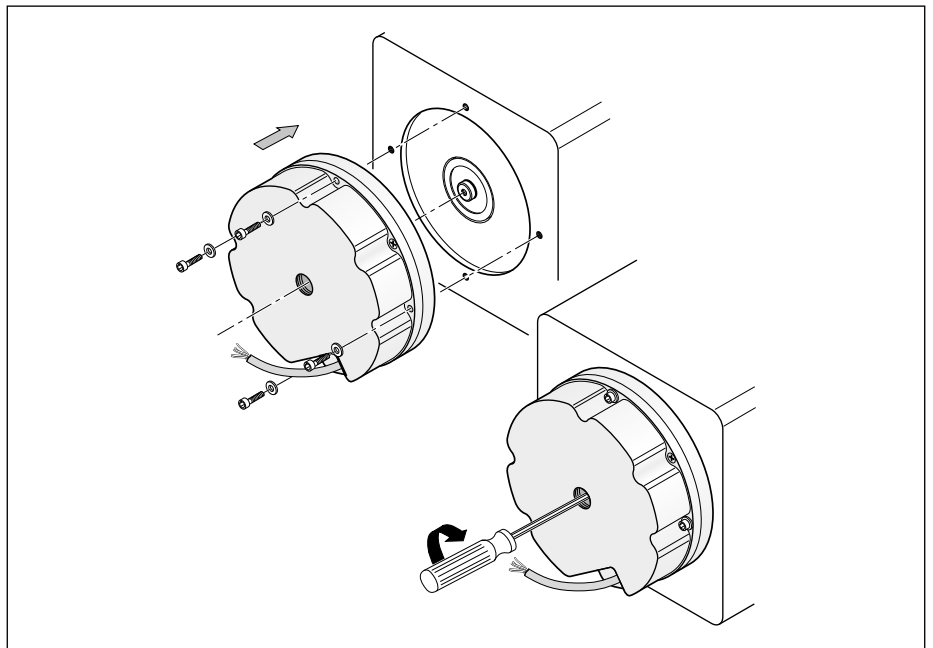

Mounting an RON 905

Materials required for mounting the RCN, ECN, RON and RPN

The machine shaft and the fastening components must be made of steel. The material must have a coefficient of thermal expansion value of $\alpha = (10 \text{ to } 16) \times 10^{-6} \text{ K}^{-1}$.

Additionally, the material must meet the following specifications:

- For hollow-shaft connection
 - $R_m \geq 650 \text{ N/mm}^2$
 - $R_{p0.2} \geq 370 \text{ N/mm}^2$ (for mechanical fault exclusion, see page 21)
- For housing connection
 - $R_{p0.2} \geq 370 \text{ N/mm}^2$

Ring nuts for RCN, ECN (Ø 20 mm), RON and RPN

HEIDENHAIN offers special ring nuts for the RCN, ECN (Ø 20 mm), RON and RPN encoders. Choose the tolerance of the shaft thread such that the ring nut can be tightened easily, with a minor axial play. This guarantees that the load is evenly distributed on the shaft connection, and prevents distortion of the encoder's hollow shaft.



- Ring nut for
 Hollow shaft Ø 20 mm: ID 336669-03
 Hollow shaft Ø 35 mm: ID 336669-17
 Hollow shaft Ø 50 mm: ID 336669-15
 Hollow shaft Ø 60 mm: ID 336669-11
 Hollow shaft Ø 100 mm: ID 336669-16

| Ring nut for | L1 | L2 | D1 | D2 | D3 | B |
|---------------------------|-----------|-------|-------------------|------------------|-------------|-----|
| Hollow shaft Ø 35 | Ø 46±0.2 | Ø 40 | (Ø 34.052 ±0.075) | Ø 34.463 ±0.053 | (Ø 35.24) | 1 |
| Hollow shaft Ø 50 | Ø 62±0.2 | Ø 55 | (Ø 49.052 ±0.075) | Ø 49.469 ±0.059 | (Ø 50.06) | 1 |
| Hollow shaft Ø 60 | Ø 70±0.2 | Ø 65 | (Ø 59.052 ±0.075) | Ø 59.469 ±0.059 | (Ø 60.06) | 1 |
| Hollow shaft Ø 100 | Ø 114±0.2 | Ø 107 | (Ø 98.538 ±0.095) | (Ø 99.163 ±0.07) | (Ø 100.067) | 1.5 |

Ring nut for hollow shaft Ø 20 mm

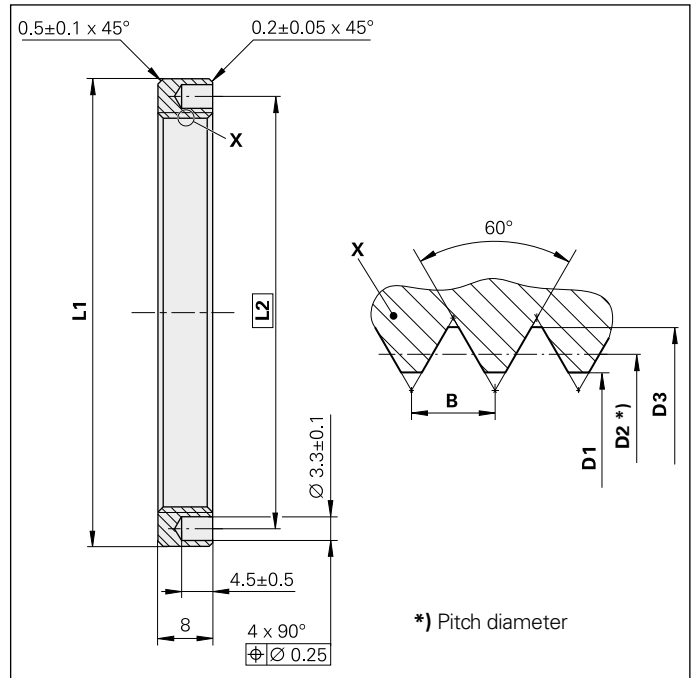
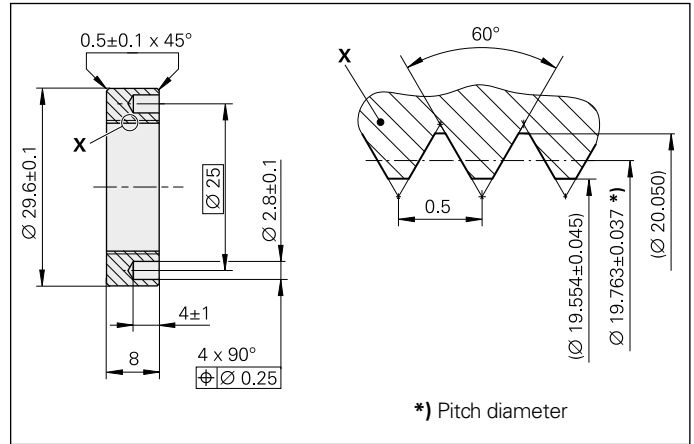

Mounting aid for HEIDENHAIN ring nuts

The mounting aid is used to tighten the ring nut. Its pins lock into the holes in the ring nut. A torque wrench provides the necessary tightening torque.

- Mounting aid for ring nuts with
 Hollow shaft Ø 20 mm: ID 530334-03
 Hollow shaft Ø 35 mm: ID 530334-17
 Hollow shaft Ø 50 mm: ID 530334-15
 Hollow shaft Ø 60 mm: ID 530334-11
 Hollow shaft Ø 100 mm: ID 530334-16

PWW inspection tool for RCN/RON/RPN angle encoders

The PWW makes it possible to simply and quickly inspect the most significant mating dimensions. The integrated measuring equipment measures position and radial runout, for example. It is best suited for the shaft coupling with ring nut.

- PWW for
 Hollow shaft Ø 20 mm: ID 516211-01
 Hollow shaft Ø 35 mm: ID 516211-06
 Hollow shaft Ø 50 mm: ID 516211-02
 Hollow shaft Ø 60 mm: ID 516211-03
 Hollow shaft Ø 100 mm: ID 516211-05



Inspection tool (PWW)

ROD

Angle encoders of the **ROD** product family require a separate coupling for connection to the drive shaft. The shaft coupling compensates axial movement and misalignment between the shafts, preventing excessive load on the bearing of the angle encoder. It is important that the encoder shaft and the drive shaft be optimally aligned for high measurement accuracies to be realized. The HEIDENHAIN product program includes diaphragm couplings and flat couplings designed for connecting the shaft of the ROD angle encoder to the drive shaft.

Mounting

ROD angle encoders are provided with an integral mounting flange with centering collar. The encoder shaft is connected to the drive shaft by way of a diaphragm coupling or flat coupling.

Shaft couplings

The shaft coupling compensates axial movement and misalignment between the encoder shaft and the drive shaft, preventing excessive load on the encoder bearing of the angle encoder.

Radial offset λ

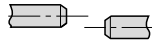

Angular error α



Axial motion δ

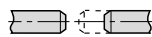

Mounting example
ROD 880

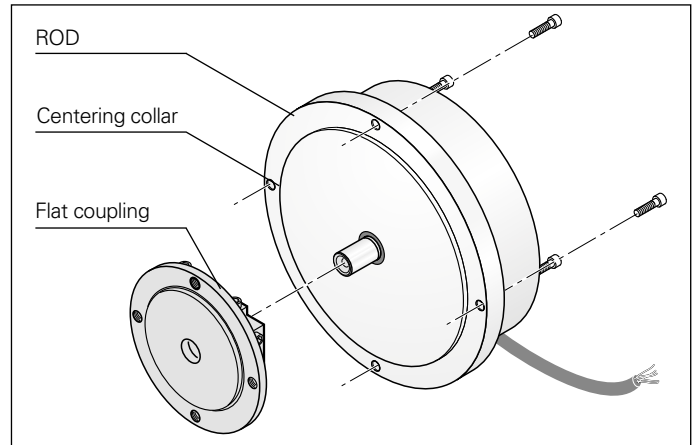
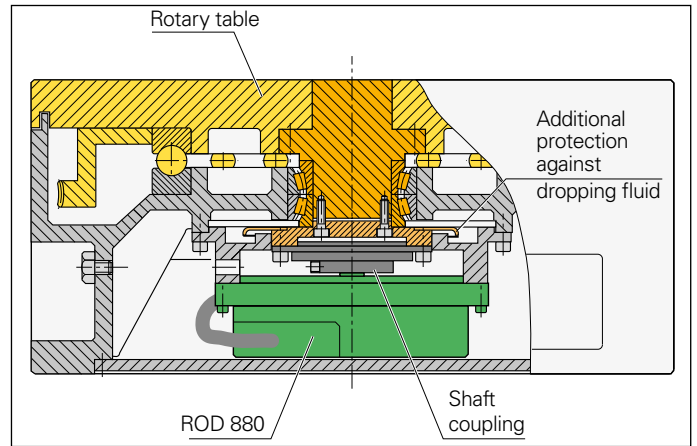

Mounting an ROD
with flat coupling

| Shaft coupling | ROD 200 series | | ROD 700 series, ROD 800 series | | |
|-------------------------------------|--|----------------------------------|-----------------------------------|---|-----------------------------------|
| | K 03 Diaphragm coupling | K 18 Flat coupling | K 01 Diaphragm coupling | K 15 Flat coupling | K 16 Flat coupling |
| Hub bore | 10 mm | | 14 mm | | |
| Kinematic transfer error | $\pm 2''$ At $\lambda \leq 0.1 \text{ mm}$ and $\alpha \leq 0.09^\circ$ | | $\pm 1''$ | $\pm 0.5''$ At $\lambda \leq 0.05 \text{ mm}$ and $\alpha \leq 0.03^\circ$ | |
| Torsional rigidity | 1500 Nm/rad | 1200 Nm/rad | 4000 Nm/rad | 6000 Nm/rad | 4000 Nm/rad |
| Permissible torque | 0.2 Nm | 0.5 Nm | | | |
| Perm. radial offset λ | $\leq 0.3 \text{ mm}$ | | | | |
| Perm. angular error α | $\leq 0.5^\circ$ | | | $\leq 0.2^\circ$ | $\leq 0.5^\circ$ |
| Perm. axial offset δ | $\leq 0.2 \text{ mm}$ | | | $\leq 0.1 \text{ mm}$ | $\leq 1 \text{ mm}$ |
| Moment of inertia (approx.) | $20 \cdot 10^{-6} \text{ kgm}^2$ | $75 \cdot 10^{-6} \text{ kgm}^2$ | $200 \cdot 10^{-6} \text{ kgm}^2$ | | $400 \cdot 10^{-6} \text{ kgm}^2$ |
| Permissible speed | 10000 min^{-1} | 1000 min^{-1} | 3000 min^{-1} | 1000 min^{-1} | |
| Torque for locking screws (approx.) | 1.2 Nm | | 2.5 Nm | 1.2 Nm | |
| Weight | 100 g | 117 g | 180 g | 250 g | 410 g |

Diaphragm coupling K 03

ID 200313-04

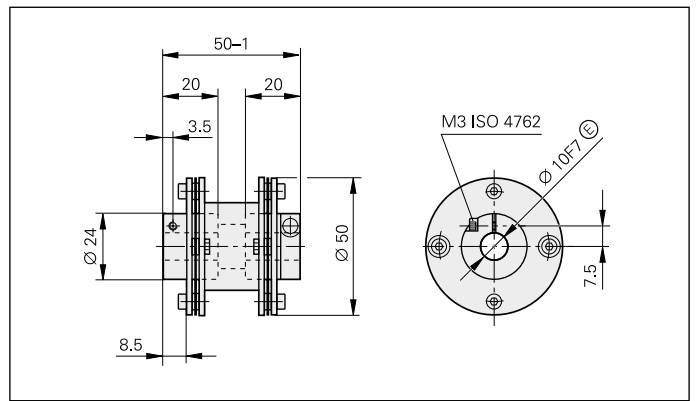

Flat coupling K 18

ID 202227-01

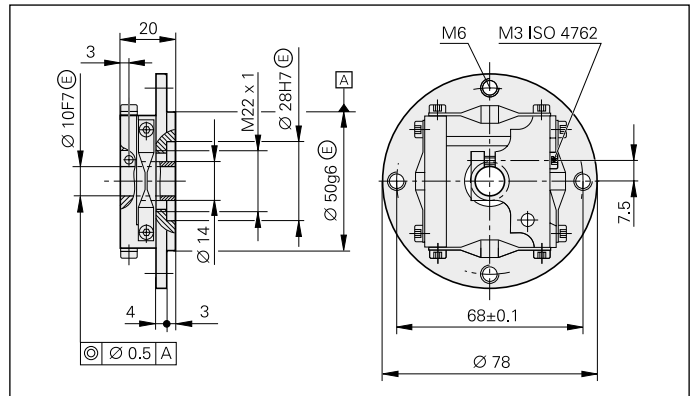

Diaphragm coupling K 01

ID 200301-02

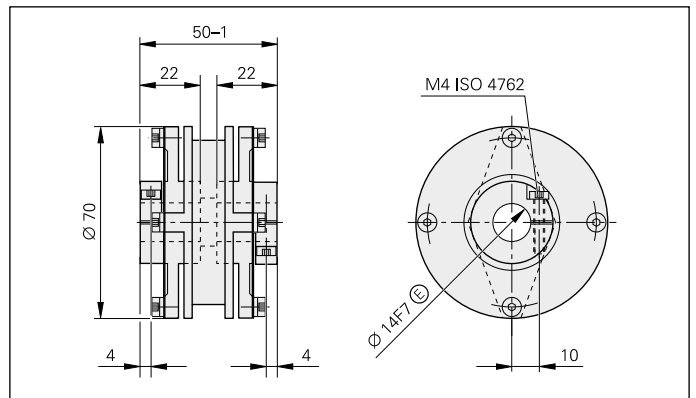

Flat coupling K 15

ID 255797-01

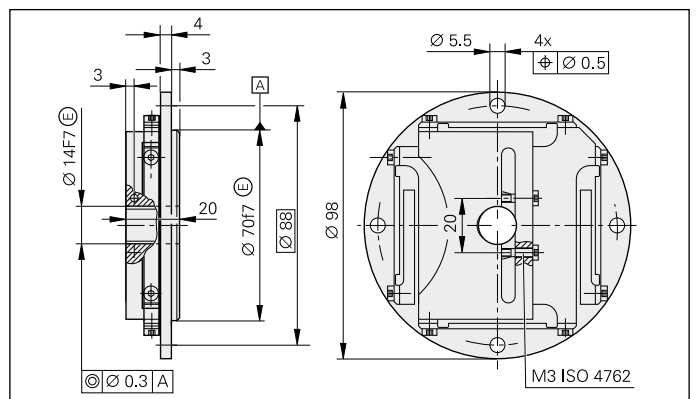

Flat coupling K 16

ID 258878-01

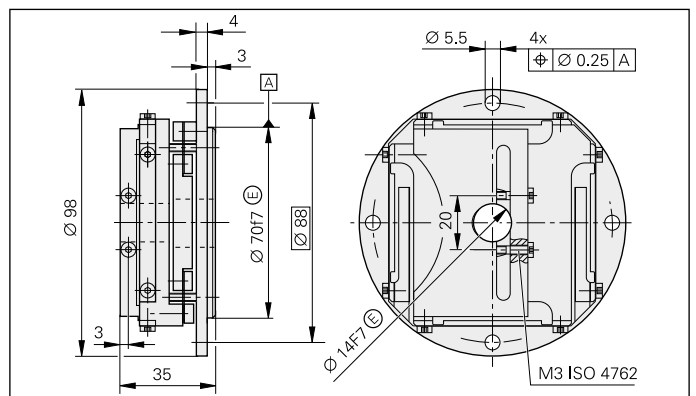

mm

 Tolerancing ISO 8015
 ISO 2768 - m H
 < 6 mm: ±0.2 mm

General mechanical information

Protection

Unless otherwise indicated, RCN, ECN, RON, RPN and ROD angle encoders meet protection standard IP 64 as per EN 60529 and IEC 60529.

Splash water must not contain any substances that would have harmful effects on the encoder's parts. If the protection to IP 64 is not sufficient, e.g. when the angle encoder is mounted vertically, additional measures such as labyrinth seals should be provided.

RCN, RON, RPN and ROD angle encoders are equipped with a compressed air inlet. Connection to a source of compressed air slightly above atmospheric pressure generates **sealing air** and provides additional protection against contamination.

The compressed air introduced directly onto the encoders must be cleaned by a micro filter, and must comply with the following quality classes as per **ISO 8573-1** (2010 edition):

- Solid contaminants: **Class 1**
Particle size No. of particles per m³
0.1 µm to 0.5 µm ≤ 20000
0.5 µm to 1.0 µm ≤ 400
1.0 µm to 5.0 µm ≤ 10
- Max. pressure dew point: (pressure dew point at 3 °C) **Class 4**
- Total oil content: **Class 1**
(max. oil concentration: 0.01 mg/m³)

For optimum supply of sealing air to the angle encoders with integral bearing, the required air flow is 1 to 4 l/min per encoder. Ideally the air flow is regulated by the HEIDENHAIN connecting pieces with integrated throttle (see *Accessories*). At an inlet pressure of $\approx 1 \cdot 10^5$ Pa (1 bar), the throttles ensure the prescribed volume of airflow.

Accessory:

DA 400 compressed air unit
ID 894602-01

DA 400

HEIDENHAIN offers the DA 400 compressed-air filter system for purifying the compressed air. It is designed specifically for the introduction of compressed air into encoders.

The DA 400 consists of three filter stages (pre-filter, fine filter and activated carbon filter) and a pressure regulator with pressure gauge. The pressure gauge and the automatic pressure switch (which is available as an accessory) effectively monitor the sealing air.

The compressed air introduced into the DA 400 must fulfill the requirements of the following purity classes as per ISO 8573-1 (2010 edition):

- Solid contaminants: **Class 5**
Particle size No. of particles per m³
0.1 µm to 0.5 µm Not specified
0.5 µm to 1.0 µm Not specified
1.0 µm to 5.0 µm ≤ 100000
- Max. pressure **Class 6**
dew point: (pressure dew point at 10 °C)
- Total oil content: **Class 4**
(max. oil concentration: 5 mg/m³)

Necessary for connection to angle encoders:

Connecting piece

For tubing 6 x 1
With throttle and gasket
For air-flow rate from 1 to 4 l/min
ID 207835-04

Also suitable:

Swiveling screw fitting 90°

With seal
ID 207834-02



DA 400

For more information, ask for our *DA 400* Product Information Sheet.

Temperature range

The angle encoders are inspected at a **reference temperature** of 22 °C. The system accuracy given in the calibration chart applies at this temperature.

The operating temperature range

indicates the ambient temperature limits between which the angle encoders will function properly.

The **storage temperature range** of –20 °C to 60 °C applies when the unit remains in its packaging. The storage temperature for the RPN 886 and RON 905 must remain between –10 °C and 50 °C.

Protection against contact

After encoder installation, all rotating parts (shaft coupling on ROD, locking ring on RCN, ECN, RON and RPN) must be protected against accidental contact during operation.

Acceleration

Angle encoders are subject to various types of acceleration during operation and mounting.

- The **permissible angular acceleration** of the rotor for the RCN/ECN/RON/RPN angle encoders is 1000 rad/s². Higher values can sometimes apply for the RCN with fault exclusion for loosening of the mechanical connection (see *Product Information document for RCN 2000, RCN 5000, RCN 8000 for Safety-Related Applications*). For the ROD angle encoders, the permissible angular acceleration varies depending on the shaft coupling and the mating shaft (details upon request).
- The indicated maximum values for **vibration** apply for frequencies of 55 Hz to 2000 Hz (EN 60068-2-6), except when mechanical resonance arises.
- The maximum permissible acceleration values (semi-sinusoidal shock) for **shock and impact** are valid for 6 ms (EN 60068-2-27). 1000 m/s² (ROD 780/880: 300 m/s²) must not be exceeded during shipping. The corresponding values for operation are listed in the specifications.

Under no circumstances should a hammer or similar implement be used to position the encoder.

Natural frequency f_N of coupling

The rotor and shaft coupling of the ROD angle encoders, as well as the stator and stator coupling of the RCN, ECN, RON and RPN angle encoders, form a single vibrating spring-mass system.

The **natural frequency f_N** should be as high as possible. For RCN, ECN, RON and RPN angle encoders, the frequency ranges given in the respective specifications are those where the natural frequencies of the encoders do not cause any significant position deviations in the measuring direction. A prerequisite for the highest possible natural frequency on **ROD angle encoders** is the use of a **shaft coupling** with a high torsional rigidity C .

$$f_N = \frac{1}{2 \cdot \pi} \cdot \sqrt{\frac{C}{I}}$$

f_N : Natural frequency in Hz

C : Torsional rigidity of the shaft coupling in Nm/rad

I : Moment of inertia of the rotor in kgm²

If radial and/or axial acceleration occurs during operation, the effect of the rigidity of the encoder bearing, the encoder stator and the coupling are also significant. If such loads occur in your application, HEIDENHAIN recommends consulting with the main facility in Traunreut.

Conditions for longer storage times

HEIDENHAIN recommends the following in order to make storage times beyond 12 months possible:

- Leave the encoders in the original packaging.
- The storage location should be dry, free of dust, and temperature-regulated. It should also not be subjected to vibrations, mechanical shock or chemical influences.
- For encoders with integral bearing, every 12 months (e.g. as run-in period) the shaft should be turned at low speeds, without axial or radial loads, so that the bearing lubricant redistributes itself evenly again.

Compensating currents

Compensating currents over the encoder bearing can negatively influence function and are therefore not permitted.

Expendable parts

HEIDENHAIN encoders contain components that are subject to wear, depending on the application and handling. These include in particular the following parts:

- LED light source
 - Cables with frequent flexing
- Additionally for encoders with integral bearing:
- Bearing
 - Shaft sealing rings for rotary and angular encoders
 - Sealing lips for sealed linear encoders

System tests

Encoders from HEIDENHAIN are usually integrated as components in larger systems. Such applications require **comprehensive tests of the entire system** regardless of the specifications of the encoder.

The specifications shown in this brochure apply to the specific encoder, not to the complete system. Any operation of the encoder outside of the specified range or for any other than the intended applications is at the user's own risk.

In safety-related systems, the higher-level system must verify the position value of the encoder after switch-on.

Assembly

Work steps to be performed and dimensions to be maintained during mounting are specified solely in the mounting instructions supplied with the unit. All data in this catalog regarding mounting are therefore provisional and not binding; they do not become terms of a contract.

RCN 2000 series

- Integrated stator coupling
- Hollow through shaft $\varnothing 20$ mm
- System accuracy $\pm 2.5''$ and $\pm 5''$
- Fault exclusion for loosening of the mechanical connection is possible

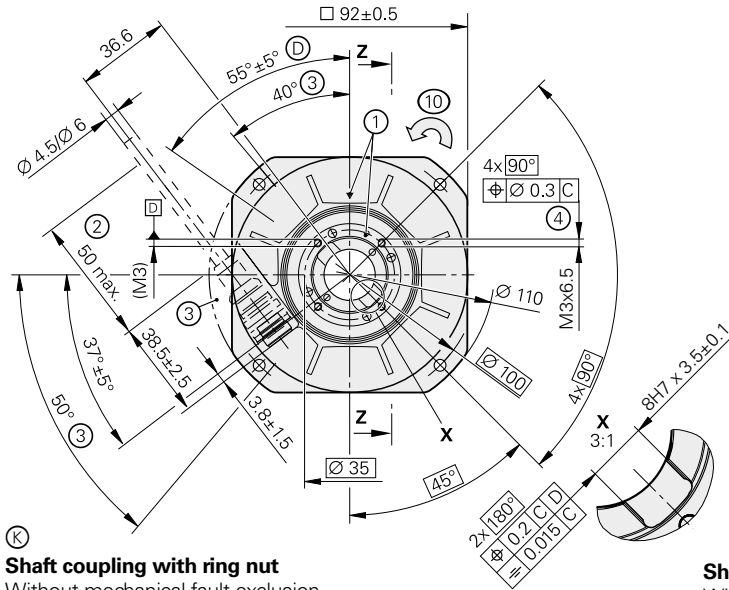

Shaft coupling with ring nut
Without mechanical fault exclusion

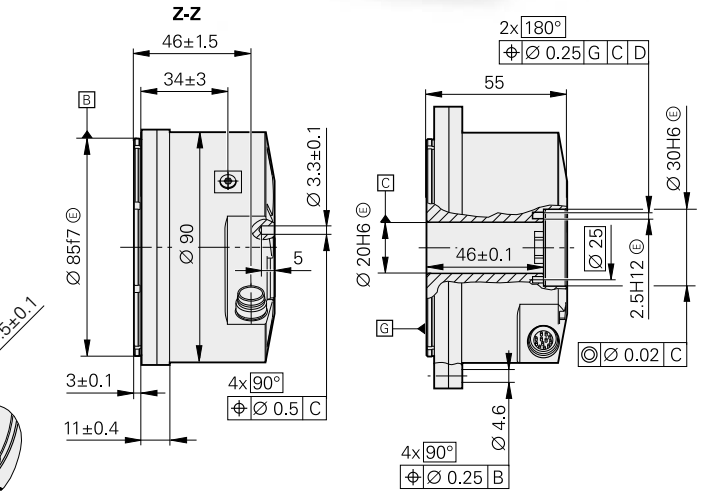

Shaft coupling with ring nut and catch
With mechanical fault exclusion
(for further dimensions, see "Without mechanical fault exclusion")

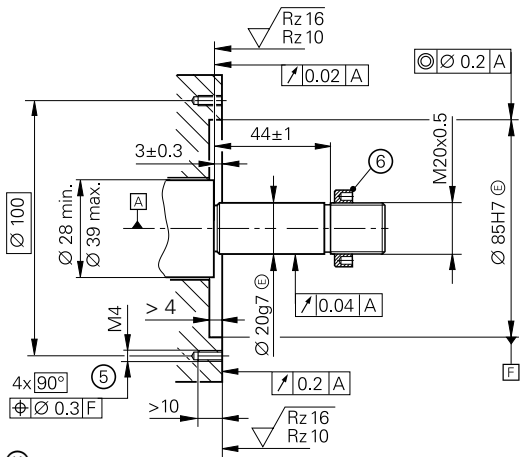

Front end shaft coupling
Without mechanical fault exclusion

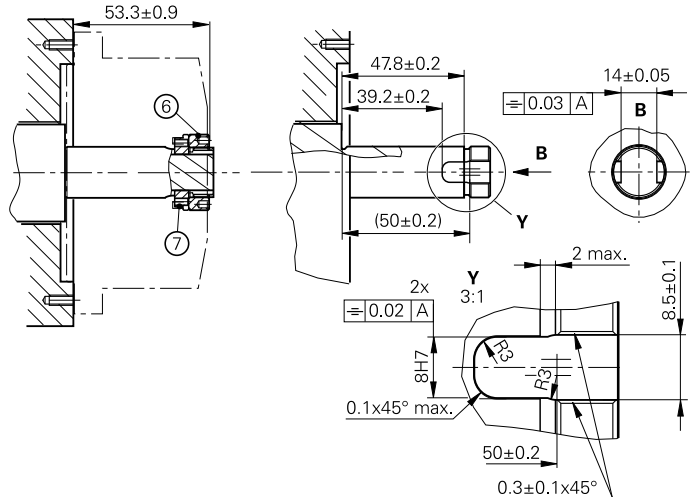

Front-end shaft coupling
With mechanical fault exclusion
(for further dimensions, see "Without mechanical fault exclusion")

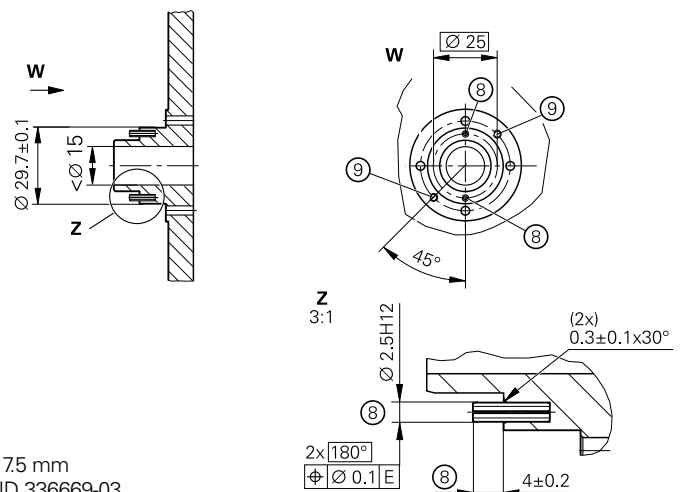
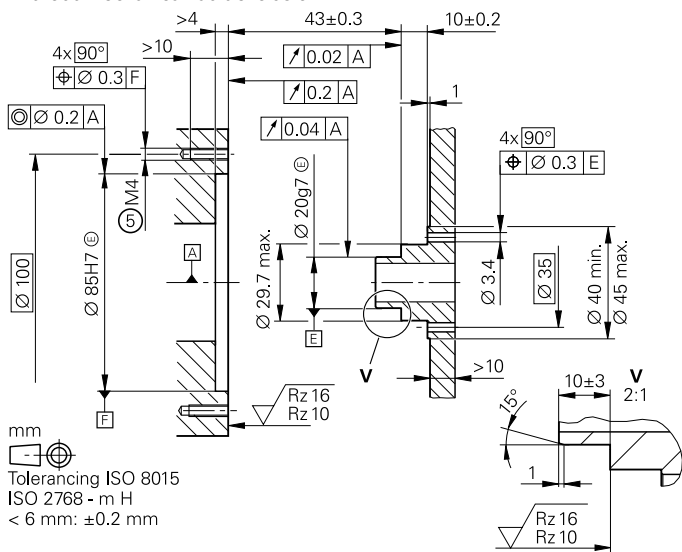

mm
Tolerancing ISO 8015
ISO 2768 - m H
< 6 mm: ± 0.2 mm

- ▭ = Bearing of mating shaft
- ⊙ = Compressed air inlet
- ⊗ = Required mating dimensions
- 1 = Mark for 0° position $\pm 5^\circ$
- 2 = Cable support
- 3 = Free space for customer
- 4 = Screw penetration 4.5 ± 0.5 mm

- 5 = Screw penetration > 7.5 mm
- 6 = Accessory: Ring nut ID 336669-03
- 7 = Accessory: Ring nut ID 817921-01
- 8 = 2x spring pins ISO 8752 - 2.5x10 - St
- 9 = When using spring pins, provide additional back-off threads (M3)
- 10 = Direction of shaft rotation for output signals as per the interface description

| | Absolute RCN 2510 RCN 2310 | RCN 2580 RCN 2380 | RCN 2590F RCN 2390F | RCN 2590M RCN 2390M |
|---|---|---|--|------------------------------------|
| Measuring standard | DIADUR circular scale with absolute and incremental track (16384 lines) | | | |
| System accuracy | <i>RCN 25x0: ± 2.5"</i> ; <i>RCN 23x0: ± 5"</i> | | | |
| Position error per signal period | <i>RCN 25x0: ≤ ± 0.3"</i> <i>RCN 23x0: ≤ ± 0.4"</i> | <i>RCN 25x0: ≤ ± 0.4"</i> <i>RCN 23x0: ≤ ± 0.4"</i> | | |
| Functional safety* | Option ¹⁾ | – | | |
| Interface | EnDat 2.2 | | Fanuc serial interface αi Interface | Mitsubishi high speed interface |
| Ordering designation | EnDat22 | EnDat02 | Fanuc05 | Mit03-4 |
| Position values/revolution | <i>RCN 25x0: 268435456 (28 bits); Fanuc α Interface: 134217728 (27 bits)</i> <i>RCN 23x0: 67108864 (26 bits); Fanuc α Interface: 8388608 (23 bits)</i> | | | |
| Elec. permissible speed | ≤ 3000 min ⁻¹ for continuous position value | ≤ 1500 min ⁻¹ for continuous position value | ≤ 3000 min ⁻¹ for continuous position value | |
| Clock frequency Calculation time t_{cal} | ≤ 16 MHz ≤ 5 μs | ≤ 2 MHz ≤ 5 μs | – | |
| Incremental signals Cutoff frequency –3 dB | – | ~ 1 V _{PP} ≥ 400 kHz | – | |
| Electrical connection | Separate adapter cable connectable to encoder via quick disconnect | | | |
| Cable length ²⁾ | ≤ 150 m | | ≤ 50 m | ≤ 30 m |
| Voltage supply | 3.6 V to 14 V DC | | | |
| Power consumption ³⁾ (max.) | 3.6 V: ≤ 1.1 W; 14 V: ≤ 1.3 W | | | |
| Current consumption (typical) | 5 V: 140 mA (without load) | | | |
| Shaft | Hollow through shaft D= 20 mm | | | |
| Mech. permissible speed | ≤ 1500 min ⁻¹ ; <i>temporary: ≤ 3000 min⁻¹</i> ⁴⁾ (Speeds over 1500 min ⁻¹ require consultation) | | | |
| Torque (friction) | ≤ 3.3 Nm (typical starting torque: ≤ 0.08 Nm at 20 °C) | | | |
| Moment of inertia | <i>Rotor (hollow shaft): 180 · 10⁻⁶ kgm²; Stator (housing/flange): 670 · 10⁻⁶ kgm²</i> | | | |
| Permissible axial motion of measured shaft | ± 0.3 mm | | | |
| Natural frequency | ≥ 1000 Hz | | | |
| Vibration 55 to 2000 Hz Shock 6 ms | ≤ 200 m/s ² (EN 60068-2-6) ≤ 200 m/s ² (EN 60068-2-27) | | | |
| Operating temperature | <i>RCN 25xx: 0 °C to 50 °C; RCN 23xx: –20 °C to 60 °C</i> ⁴⁾ | | | |
| Protection EN 60 529 | IP 64 | | | |
| Weight | ≈ 1.0 kg | | | |

* Please indicate when ordering

²⁾ With HEIDENHAIN cable; ≤ 8 MHz⁴⁾ For mechanical fault exclusion, see page 21¹⁾ For dimensions and specifications, see separate Product Information document³⁾ See *General electrical information* in the catalog *Interfaces of HEIDENHAIN Encoders*

RON 200 series

- Integrated stator coupling
- Hollow through shaft $\varnothing 20$ mm
- System accuracy $\pm 2.5''$ and $\pm 5''$

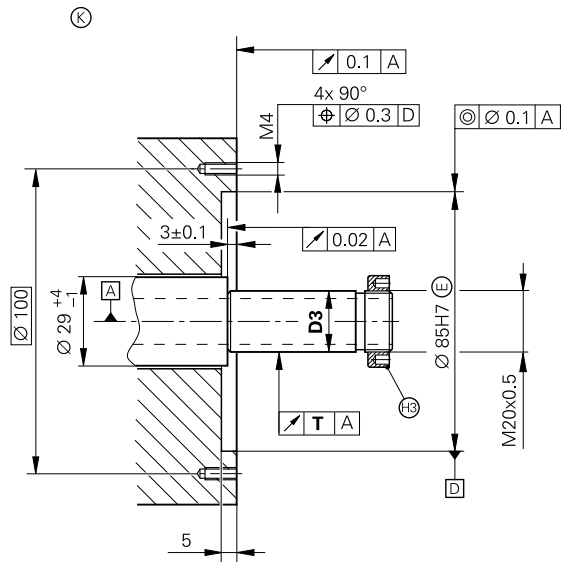
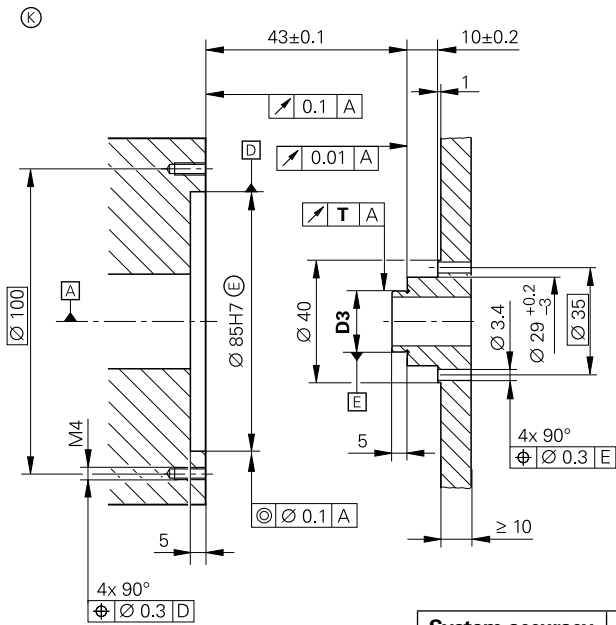
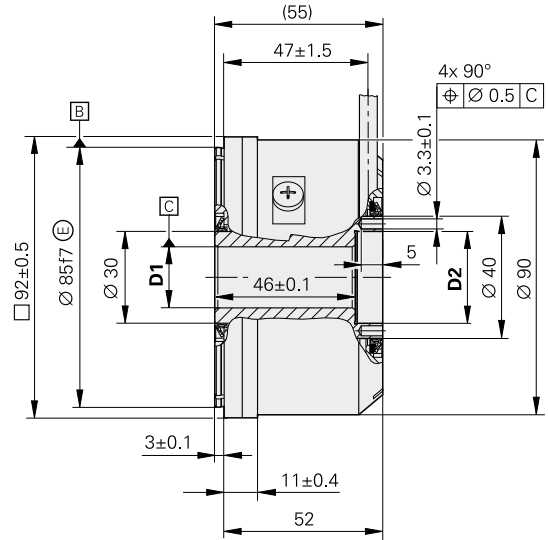
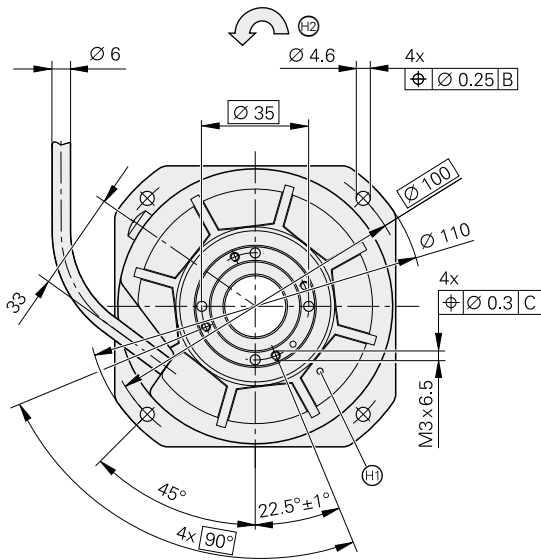

| System accuracy | $\pm 2.5''$ | $\pm 5''$ |
|-----------------|------------------------------|------------------------------|
| D1 | $\varnothing 20H6 \text{ E}$ | $\varnothing 20H7 \text{ E}$ |
| D2 | $\varnothing 30H6 \text{ E}$ | $\varnothing 30H7 \text{ E}$ |
| D3 | $\varnothing 20g6 \text{ E}$ | $\varnothing 20g7 \text{ E}$ |
| T | 0.01 | 0.02 |

mm

 Tolerancing ISO 8015
 ISO 2768 - m H
 < 6 mm: ± 0.2 mm

Cable radial, also usable axially
 A = Bearing of mating shaft
 K = Required mating dimensions
 H = Position of the reference mark signal $\pm 5^\circ$
 E = Direction of shaft rotation for output signals as per the interface description
 C = Accessory: Ring nut ID 336669-03

| | Incremental RON 225 | RON 275 | RON 275 | RON 285 | RON 287 |
|---|--|-------------------------|-------------------------|--|----------------|
| Measuring standard | DIADUR circular scale with incremental track | | | | |
| Line count | 9000 | 18000 | | | |
| System accuracy | ± 5" | | | | ± 2.5" |
| Position error per signal period | ≤ ± 1.4" | ≤ ± 0.7" | | | |
| Interface | □□TTL | | | ~ 1 V _{PP} | |
| Integrated interpolation* Output signals/rev | 2-fold 18000 | 5-fold 90000 | 10-fold 180000 | – | |
| Reference mark* | One | | | RON 2xx: One RON 2xxC: Distance-coded | |
| Cutoff frequency –3 dB | – | – | – | ≥ 180 kHz | |
| Output frequency | ≤ 1 MHz | ≤ 250 kHz | ≤ 1 MHz | – | |
| Edge separation a | ≥ 0.125 μs | ≥ 0.96 μs | ≥ 0.22 μs | – | |
| Elec. permissible speed | – | ≤ 166 min ⁻¹ | ≤ 333 min ⁻¹ | – | |
| Electrical connection* | Cable 1 m, with or without M23 coupling (male, 12-pin) | | | | |
| Cable length ¹⁾ | ≤ 50 m | | | ≤ 150 m | |
| Voltage supply | 5 V DC ± 0.5 V/≤ 150 mA (without load) | | | | |
| Shaft | Hollow through shaft D= 20 mm | | | | |
| Mech. permissible speed | ≤ 3000 min ⁻¹ | | | | |
| Starting torque | ≤ 0.08 Nm at 20 °C | | | | |
| Moment of inertia of rotor | 73.0 · 10 ⁻⁶ kgm ² | | | | |
| Permissible axial motion of measured shaft | ± 0.1 mm | | | | |
| Natural frequency | ≥ 1200 Hz | | | | |
| Vibration 55 to 2000 Hz | ≤ 100 m/s ² (EN 60068-2-6) | | | | |
| Shock 6 ms | ≤ 200 m/s ² (EN 60068-2-27) | | | | |
| Operating temperature | Moving cable: –10 °C to 70 °C Stationary cable: –20 °C to 70 °C | | | | 0 °C to +50 °C |
| Protection EN 60 529 | IP 64 | | | | |
| Weight | ≈ 0.8 kg | | | | |

* Please select when ordering

¹⁾ With HEIDENHAIN cable

RCN 5000 series

- Integrated stator coupling
- Hollow through shaft $\varnothing 35$ mm
- System accuracy $\pm 2.5''$ and $\pm 5''$
- Fault exclusion for loosening of the mechanical connection is possible

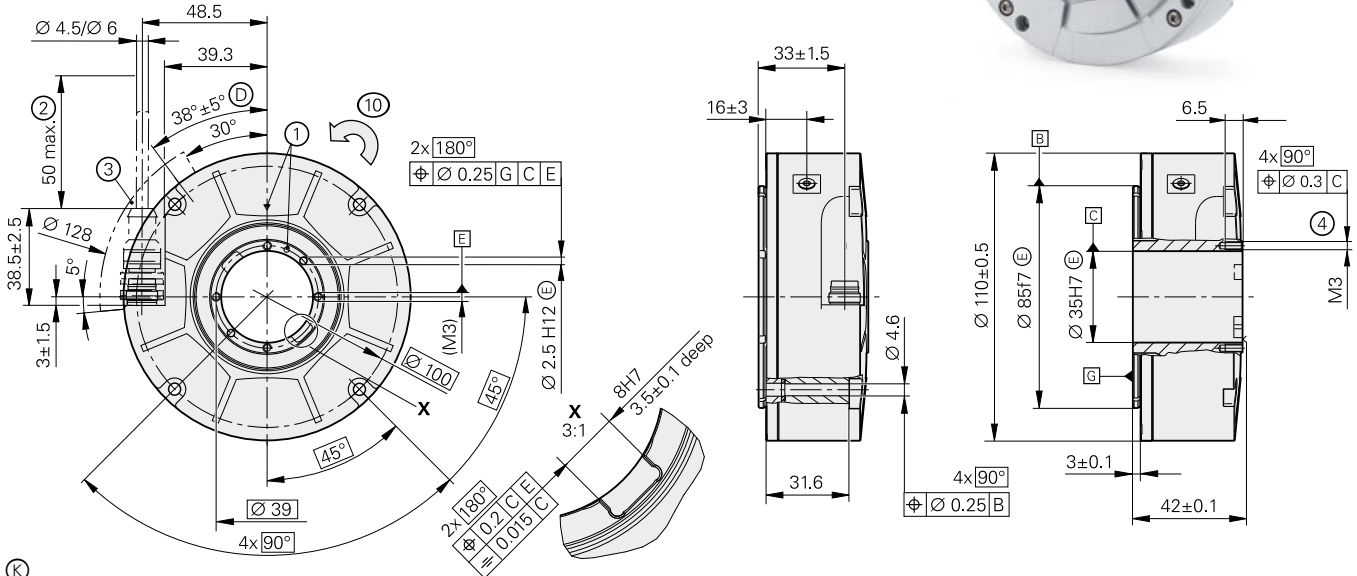

Shaft coupling with ring nut
Without mechanical fault exclusion

Shaft coupling with ring nut and catch
With mechanical fault exclusion
(for further dimensions, see "Without mechanical fault exclusion")

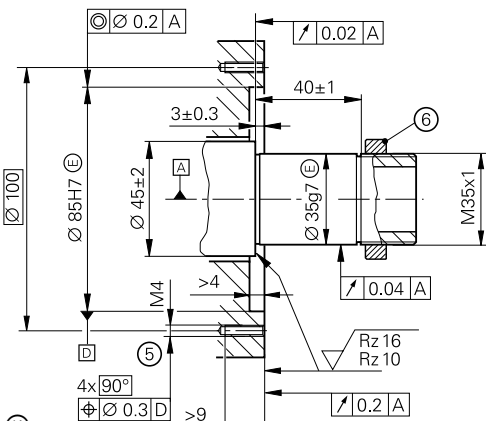

Front end shaft coupling
Without mechanical fault exclusion

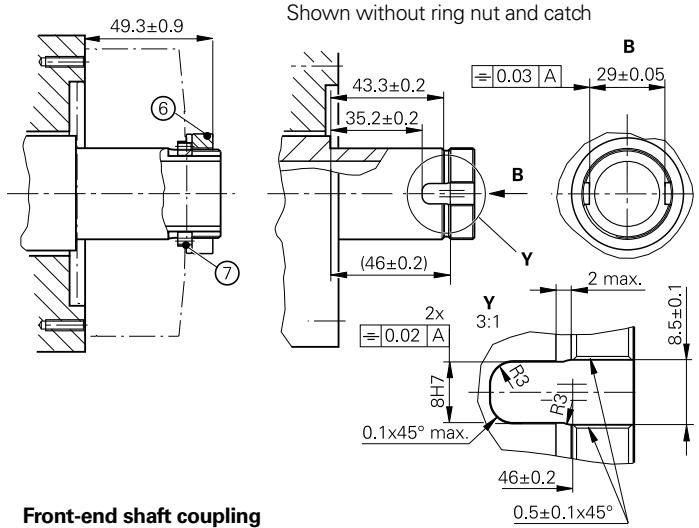

Front-end shaft coupling
With mechanical fault exclusion
(for further dimensions, see "Without mechanical fault exclusion")

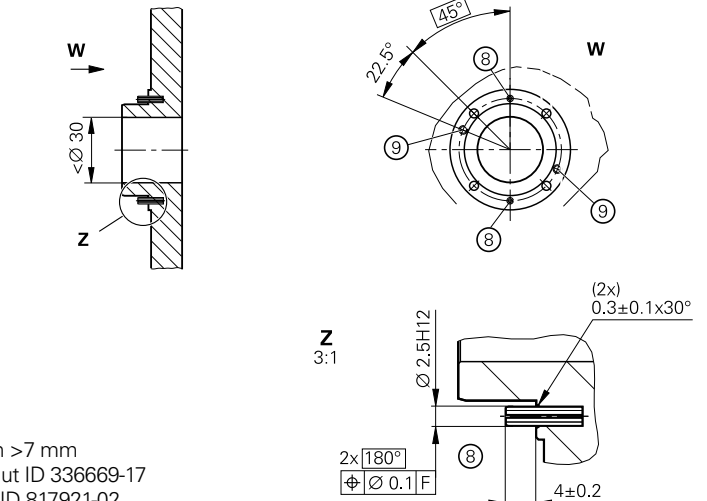
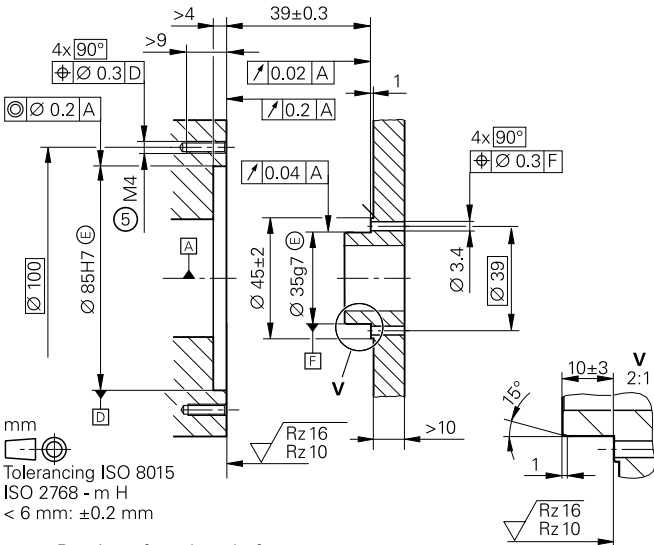

- ▣ = Bearing of mating shaft
- ⊙ = Compressed air inlet
- ⊕ = Required mating dimensions
- 1 = Mark for 0° position $\pm 5^\circ$
- 2 = Cable support
- 3 = Free space for customer
- 4 = Screw penetration 4.5 ± 0.5 mm

- 5 = Screw penetration >7 mm
- 6 = Accessory: Ring nut ID 336669-17
- 7 = Accessory: Catch ID 817921-02
- 8 = 2x spring pins ISO 8752 – 2.5x10 – St
- 9 = When using spring pins, provide additional back-off threads (M3)
- 10 = Direction of shaft rotation for output signals as per the interface description

| | Absolute RCN 5510 RCN 5310 | RCN 5580 RCN 5380 | RCN 5590F RCN 5390F | RCN 5590M RCN 5390M |
|---|---|--|--|---------------------------------|
| Measuring standard | DIADUR circular scale with absolute and incremental track (16384 lines) | | | |
| System accuracy | <i>RCN 55x0: ± 2.5"; RCN 53x0: ± 5"</i> | | | |
| Position error per signal period | <i>RCN 55x0: ≤ ± 0.3" RCN 53x0: ≤ ± 0.4"</i> | <i>RCN 55x0: ≤ ± 0.4" RCN 53x0: ≤ ± 0.4"</i> | | |
| Functional safety* | Option ¹⁾ | – | | |
| Interface | EnDat 2.2 | | Fanuc serial interface αi Interface | Mitsubishi high speed interface |
| Ordering designation | EnDat22 | EnDat02 | Fanuc05 | Mit03-4 |
| Position values/revolution | <i>RCN 55x0: 268435456 (28 bits); Fanuc α Interface: 134217728 (27 bits) RCN 53x0: 67108864 (26 bits); Fanuc α Interface: 8388608 (23 bits)</i> | | | |
| Elec. permissible speed | ≤ 3000 min ⁻¹ for continuous position value | ≤ 1500 min ⁻¹ for continuous position value | ≤ 3000 min ⁻¹ for continuous position value | |
| Clock frequency Calculation time t_{cal} | ≤ 16 MHz ≤ 5 μs | ≤ 2 MHz ≤ 5 μs | – | |
| Incremental signals Cutoff frequency –3 dB | – | $\sim 1 V_{PP}$ ≥ 400 kHz | – | |
| Electrical connection | Separate adapter cable connectable to encoder via quick disconnect | | | |
| Cable length ²⁾ | ≤ 150 m | | ≤ 50 m | ≤ 30 m |
| Voltage supply | 3.6 V to 14 V DC | | | |
| Power consumption ³⁾ (max.) | 3.6 V: ≤ 1.1 W; 14 V: ≤ 1.3 W | | | |
| Current consumption (typical) | 5 V: 140 mA (without load) | | | |
| Shaft | Hollow through shaft D = 35 mm | | | |
| Mech. permissible speed | ≤ 1500 min ⁻¹ ; <i>temporary: ≤ 3000 min⁻¹</i> ⁴⁾ (Speeds over 1500 min ⁻¹ require consultation) | | | |
| Torque (friction) | ≤ 3.38 Nm (typical starting torque: ≤ 0.2 Nm at 20 °C) | | | |
| Moment of inertia | <i>Rotor (hollow shaft): 130 · 10⁻⁶ kgm²; Stator (housing/flange): 1010 · 10⁻⁶ kgm²</i> | | | |
| Permissible axial motion of measured shaft | ± 0.3 mm | | | |
| Natural frequency | ≥ 1000 Hz | | | |
| Vibration 55 to 2000 Hz Shock 6 ms | ≤ 200 m/s ² (EN 60068-2-6) ≤ 200 m/s ² (EN 60068-2-27) | | | |
| Operating temperature | <i>RCN 55xx: 0 °C to 50 °C; RCN 53xx: –20 °C to 60 °C</i> ⁴⁾ | | | |
| Protection EN 60 529 | IP 64 | | | |
| Weight | ≈ 0.9 kg | | | |

* Please indicate when ordering

²⁾ With HEIDENHAIN cable; ≤ 8 MHz

⁴⁾ For mechanical fault exclusion, see page 21

¹⁾ For dimensions and specifications, see separate Product Information document

³⁾ See *General electrical information* in the catalog *Interfaces of HEIDENHAIN Encoders*

RON 785

- Integrated stator coupling
- Hollow through shaft $\varnothing 50$ mm
- System accuracy $\pm 2''$

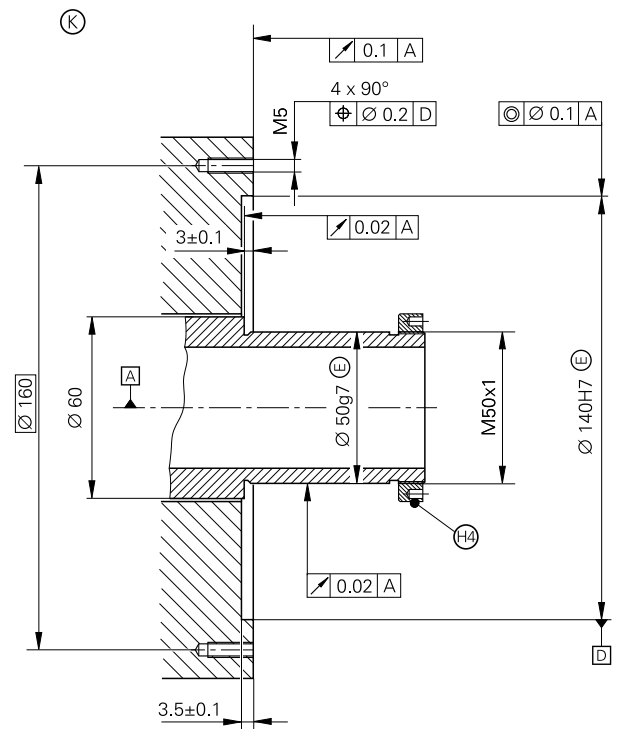
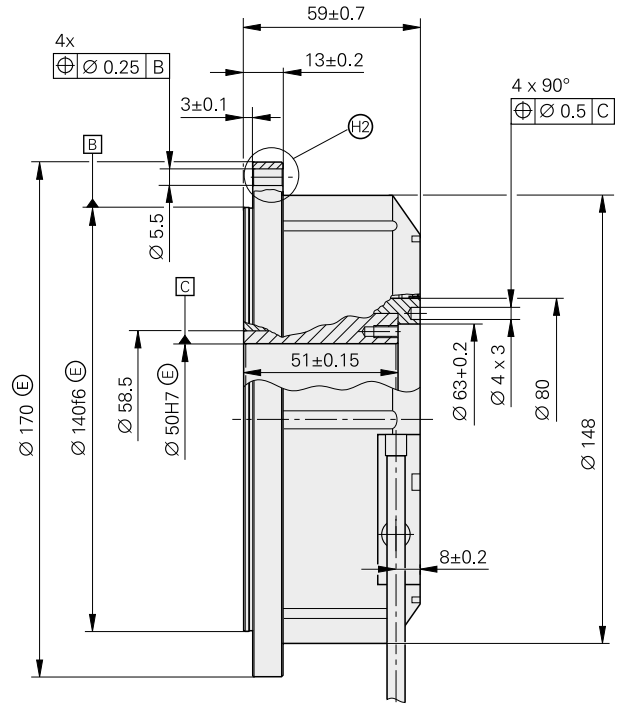
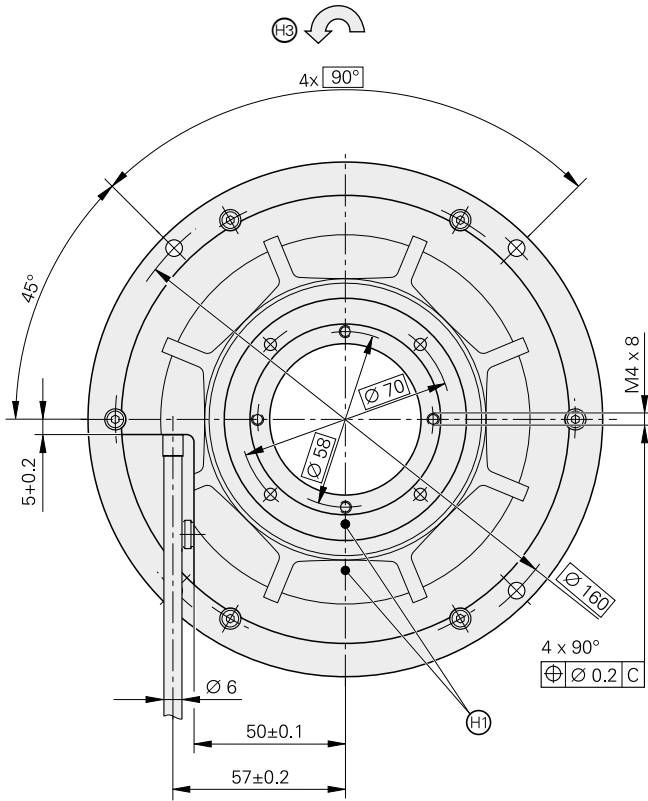

mm

 Tolerancing ISO 8015
 ISO 2768 - m H
 < 6 mm: ± 0.2 mm

Cable radial, also usable axially
 ▣ = Bearing of mating shaft
 Ⓞ = Required mating dimensions
 ⊕ = Position of the reference mark signal $\pm 5''$
 ⊕ = Shown rotated by $45''$
 ⊕ = Direction of shaft rotation for output signals according to interface description
 ⊕ = Accessory: Ring nut ID 336669-15

| | Incremental RON 785 |
|---|---|
| Measuring standard | DIADUR circular scale with incremental track |
| Line count | 18000 |
| System accuracy | ± 2" |
| Position error per signal period | ≤ ± 0.7" |
| Interface | ~ 1 V _{PP} |
| Reference mark* | <i>RON 785</i> : One <i>RON 785C</i> : Distance-coded |
| Cutoff frequency -3 dB | ≥ 180 kHz |
| Electrical connection* | Cable 1 m, with or without M23 coupling (male, 12-pin) |
| Cable length ¹⁾ | ≤ 150 m |
| Voltage supply | 5 V DC ± 0.5 V/≤ 150 mA (without load) |
| Shaft | Hollow through shaft D = 50 mm |
| Mech. permissible speed | ≤ 1000 min ⁻¹ |
| Starting torque | ≤ 0.5 Nm at 20 °C |
| Moment of inertia of rotor | 1.05 · 10 ⁻³ kgm ² |
| Permissible axial motion of measured shaft | ± 0.1 mm |
| Natural frequency | ≥ 1000 Hz |
| Vibration 55 to 2000 Hz Shock 6 ms | ≤ 100 m/s ² (EN 60068-2-6) ≤ 200 m/s ² (EN 60068-2-27) |
| Operating temperature | 0 °C to +50 °C |
| Protection EN 60 529 | IP 64 |
| Weight | ≈ 2.5 kg |

* Please select when ordering

¹⁾ With HEIDENHAIN cable

RCN 8000 series

- Integrated stator coupling
- Hollow through shaft $\varnothing 60$ mm
- System accuracy $\pm 1''$ and $\pm 2''$
- Fault exclusion for loosening of the mechanical connection is possible

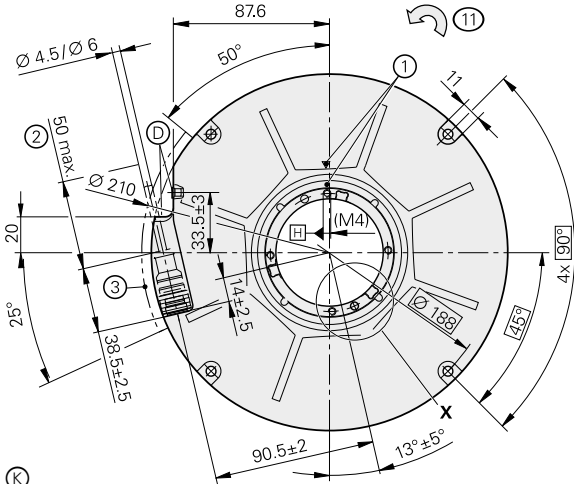

Shaft coupling with ring nut
Without mechanical fault exclusion

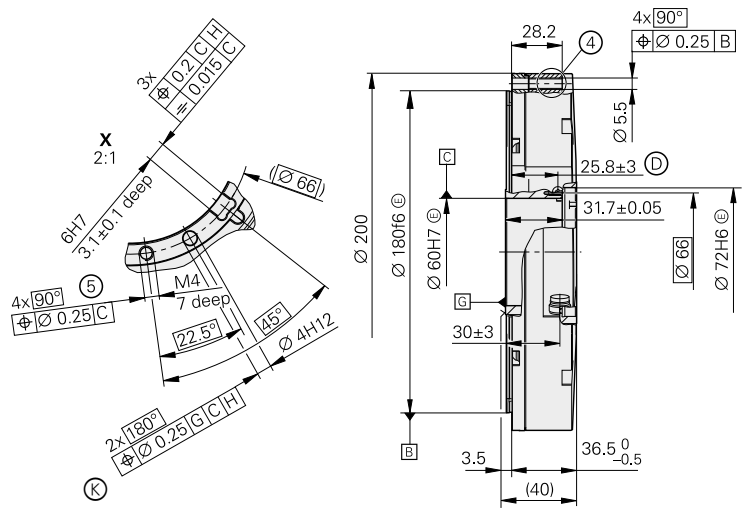

Front end shaft coupling
Without mechanical fault exclusion

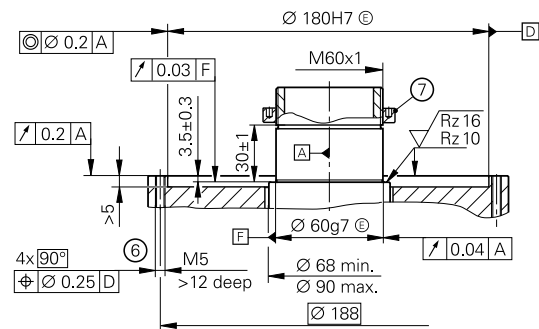

Shaft coupling with ring nut and catch
With mechanical fault exclusion
(for further dimensions, see "Without mechanical fault exclusion")

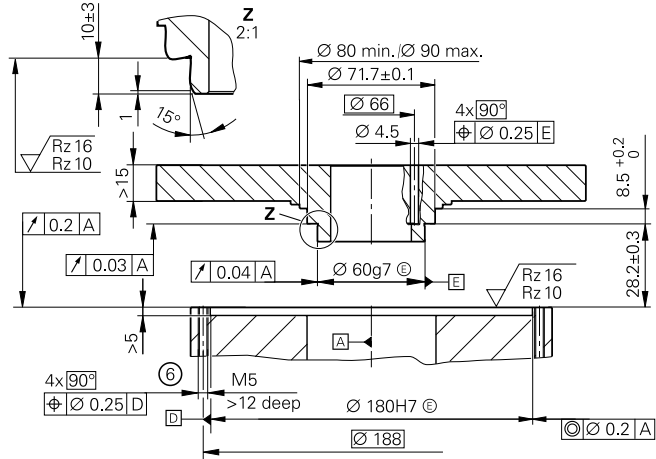

Front-end shaft coupling
With mechanical fault exclusion
(for further dimensions, see "Without mechanical fault exclusion")

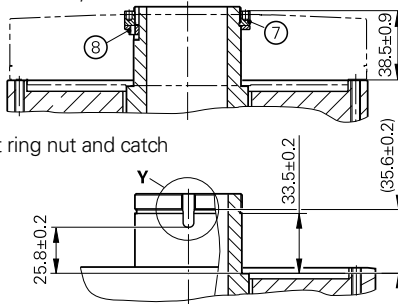

Shown without ring nut and catch

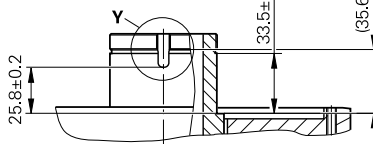

mm
Tolerancing ISO 8015
ISO 2768 - m H
< 6 mm: ± 0.2 mm

- ▣ = Bearing
- ⊙ = Compressed air inlet
- ⊗ = Required mating dimensions
- 1 = Mark for 0° position $\pm 5^\circ$
- 2 = Cable support
- 3 = Free space for customer
- 4 = Shown rotated by 45°
- 5 = Screw penetration 5.5 ± 0.5 mm
- 6 = Screw penetration > 10 mm
- 7 = Accessory: Ring nut ID 336669-11
- 8 = Accessory: Catch ID 817921-03
- 9 = 2x spring pins ISO 8752 - 4x10 - St
- 10 = When using spring pins, provide additional back-off threads (M4)
- 11 = Direction of shaft rotation for output signals as per the interface description

| | Absolute RCN 8510 RCN 8310 | RCN 8580 RCN 8380 | RCN 8590F RCN 8390F | RCN 8590M RCN 8390M |
|---|--|---|--|---------------------------------|
| Measuring standard | DIADUR circular scale with absolute and incremental track (32 768 lines) | | | |
| System accuracy | <i>RCN 85x0: ± 1''; RCN 83x0: ± 2''</i> | | | |
| Position error per signal period | <i>RCN 85x0: ≤ ± 0.15'' RCN 83x0: ≤ ± 0.2''</i> | <i>RCN 85x0: ≤ ± 0.2'' RCN 83x0: ≤ ± 0.2''</i> | | |
| Functional safety* | Option ¹⁾ | – | | |
| Interface | EnDat 2.2 | | Fanuc serial interface αi Interface | Mitsubishi high speed interface |
| Ordering designation | EnDat22 | EnDat02 | Fanuc05 | Mit03-4 |
| Position values/revolution | 536870912 (29 bits); <i>Fanuc α Interface: 134217 728 (27 bits)</i> | | | |
| Elec. permissible speed | ≤ 1500 min ⁻¹ for continuous position value | ≤ 750 min ⁻¹ for continuous position value | ≤ 1500 min ⁻¹ for continuous position value | |
| Clock frequency Calculation time t_{cal} | ≤ 16 MHz ≤ 5 μs | ≤ 2 MHz ≤ 5 μs | – | |
| Incremental signals Cutoff frequency –3 dB | – | $\sim 1 V_{PP}$ ≥ 400 kHz | – | |
| Electrical connection | Separate adapter cable connectable to encoder via quick disconnect | | | |
| Cable length ²⁾ | ≤ 150 m | | ≤ 50 m | ≤ 30 m |
| Voltage supply | 3.6 V to 14 V DC | | | |
| Power consumption ³⁾ (max.) | 3.6 V: ≤ 1.1 W; 14 V: ≤ 1.3 W | | | |
| Current consumption (typical) | 5 V: 140 mA (without load) | | | |
| Shaft | Hollow through shaft D = 60 mm | | | |
| Mech. permissible speed | ≤ 500 min ⁻¹ ; <i>temporary: ≤ 1500 min⁻¹</i> ⁴⁾ (Speeds over 500 min ⁻¹ require consultation) | | | |
| Torque (friction) | ≤ 4.05 Nm (typical starting torque: ≤ 0.7 Nm at 20 °C) | | | |
| Moment of inertia | <i>Rotor (hollow shaft): 1.22 · 10⁻³ kgm²; Stator (housing/flange): 11.0 · 10⁻³ kgm²</i> | | | |
| Permissible axial motion of measured shaft | ± 0.3 mm | | | |
| Natural frequency | ≥ 900 Hz | | | |
| Vibration 55 to 2000 Hz Shock 6 ms | ≤ 200 m/s ² (EN 60068-2-6) ≤ 200 m/s ² (EN 60068-2-27) | | | |
| Operating temperature | 0 °C to +50 °C | | | |
| Protection EN 60 529 | IP 64 | | | |
| Weight | ≈ 2.8 kg | | | |

* Please indicate when ordering

²⁾ With HEIDENHAIN cable; ≤ 8 MHz

⁴⁾ For mechanical fault exclusion, see page 21

¹⁾ For dimensions and specifications, see separate Product Information document

³⁾ See *General electrical information* in the catalog *Interfaces of HEIDENHAIN Encoders*

RCN 8000 series

- Integrated stator coupling
- Hollow through shaft $\varnothing 100$ mm
- System accuracy $\pm 1''$ and $\pm 2''$
- Fault exclusion for loosening of the mechanical connection is possible

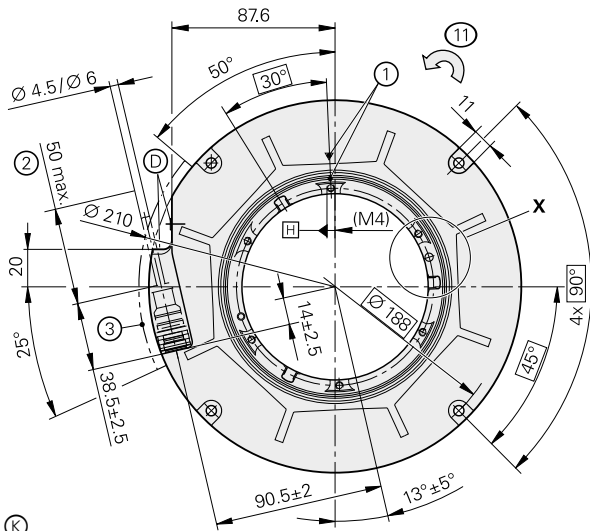

Shaft coupling with ring nut
Without mechanical fault exclusion

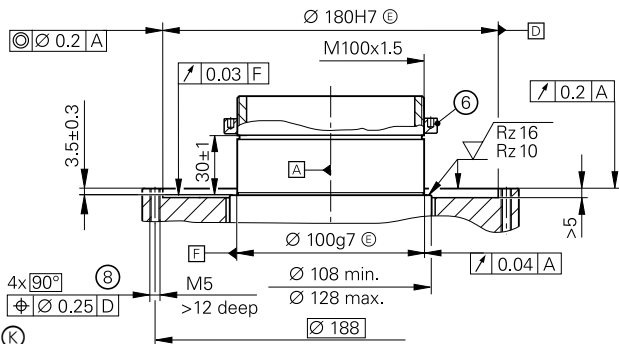

Shaft connection with ring nut and catch
With mechanical fault exclusion
(for further dimensions, see "Without mechanical fault exclusion")

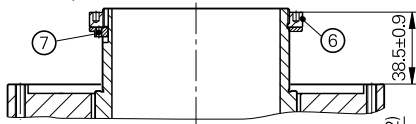

Shown without ring nut and catch

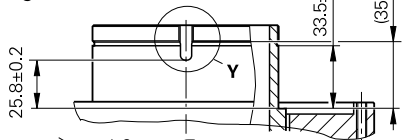

mm
Tolerancing ISO 8015
ISO 2768 - m H
< 6 mm: ±0.2 mm

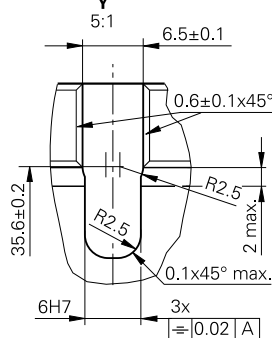
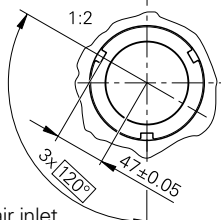

- ▣ = Bearing
- ⊙ = Compressed air inlet
- ⊕ = Required mating dimensions
- 1 = Mark for 0° position $\pm 5^\circ$
- 2 = Cable support
- 3 = Free space for customer
- 4 = Screw penetration 5.5 ± 0.5 mm
- 5 = Shown rotated by 45°
- 6 = Accessory: Ring nut ID 336669-16
- 7 = Accessory: Catch ID 817921-04
- 8 = Screw penetration > 10 mm
- 9 = 2x spring pins ISO 8752 - 4x10 - St
- 10 = When using spring pins, provide additional back-off threads (M4)
- 11 = Direction of shaft rotation for output signals as per the interface description

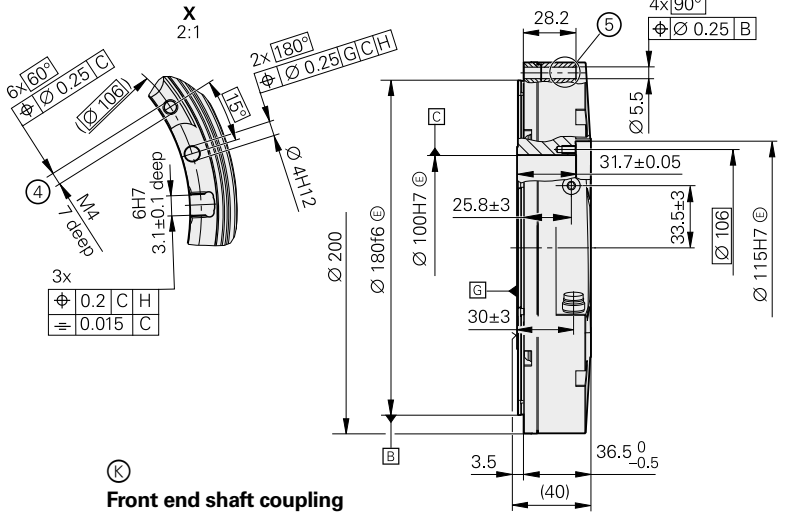

Front end shaft coupling
Without mechanical fault exclusion

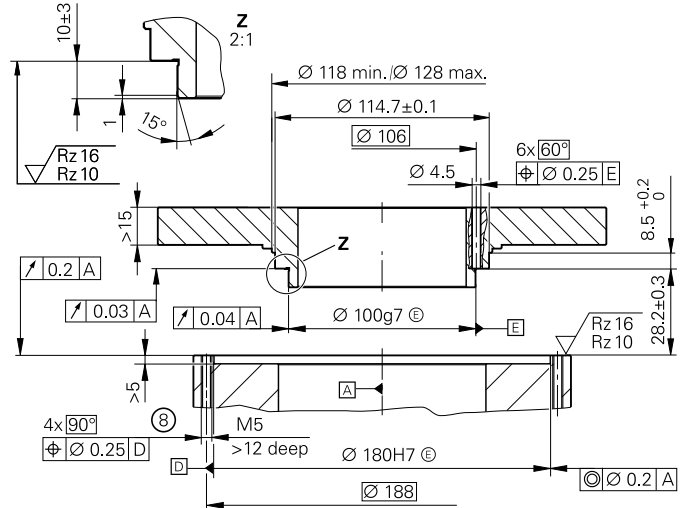

Front-end shaft coupling
With mechanical fault exclusion
(for further dimensions, see "Without mechanical fault exclusion")

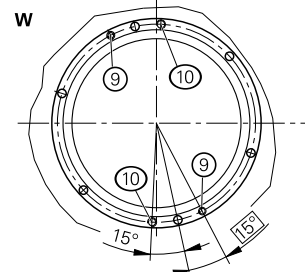
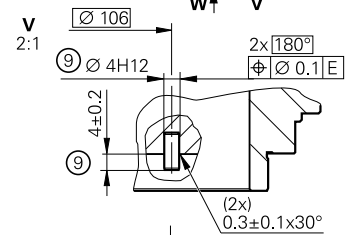
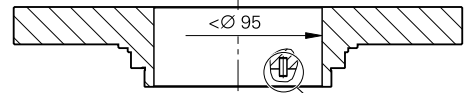

| | Absolute RCN 8510 RCN 8310 | RCN 8580 RCN 8380 | RCN 8590F RCN 8390F | RCN 8590M RCN 8390M |
|--|--|--|--|------------------------------------|
| Measuring standard | DIADUR circular scale with absolute and incremental track (32 768 lines) | | | |
| System accuracy | <i>RCN 85x0: ± 1"; RCN 83x0: ± 2"</i> | | | |
| Position error per signal period | <i>RCN 85x0: ≤ ± 0.15" RCN 83x0: ≤ ± 0.2"</i> | <i>RCN 85x0: ≤ ± 0.2" RCN 83x0: ≤ ± 0.2"</i> | | |
| Functional safety* | Option ¹⁾ | – | | |
| Interface | EnDat 2.2 | | Fanuc serial interface αi Interface | Mitsubishi high speed interface |
| Ordering designation | EnDat22 | EnDat02 | Fanuc05 | Mit03-4 |
| Position values/revolution | 536870912 (29 bits); <i>Fanuc α Interface: 134217 728 (27 bits)</i> | | | |
| Elec. permissible speed | ≤ 1500 min ⁻¹ for continuous position value | ≤ 750 min ⁻¹ for continuous position value | ≤ 1500 min ⁻¹ for continuous position value | |
| Clock frequency Calculation time t _{cal} | ≤ 16 MHz ≤ 5 μs | ≤ 2 MHz ≤ 5 μs | – | |
| Incremental signals Cutoff frequency –3 dB | – | ~ 1 V _{PP} ≥ 400 kHz | – | |
| Electrical connection | Separate adapter cable connectable to encoder via quick disconnect | | | |
| Cable length ²⁾ | ≤ 150 m | | ≤ 50 m | ≤ 30 m |
| Voltage supply | 3.6 V to 14 V DC | | | |
| Power consumption ³⁾ (max.) | 3.6 V: ≤ 1.1 W; 14 V: ≤ 1.3 W | | | |
| Current consumption (typical) | 5 V: 140 mA (without load) | | | |
| Shaft | Hollow through shaft D = 100 mm | | | |
| Mech. permissible speed | ≤ 500 min ⁻¹ ; <i>temporary: ≤ 1500 min⁻¹</i> ⁴⁾ (Speeds over 500 min ⁻¹ require consultation) | | | |
| Torque (friction) | ≤ 4.5 Nm (typical starting torque: ≤ 1.0 Nm at 20 °C) | | | |
| Moment of inertia | <i>Rotor (hollow shaft): 3.20 · 10⁻³ kgm²; Stator (housing/flange): 10.0 · 10⁻³ kgm²</i> | | | |
| Permissible axial motion of measured shaft | ± 0.3 mm | | | |
| Natural frequency | ≥ 900 Hz | | | |
| Vibration 55 to 2000 Hz Shock 6 ms | ≤ 200 m/s ² (EN 60068-2-6) ≤ 200 m/s ² (EN 60068-2-27) | | | |
| Operating temperature | 0 °C to +50 °C | | | |
| Protection EN 60 529 | IP 64 | | | |
| Weight | ≈ 2.6 kg | | | |

* Please indicate when ordering

²⁾ With HEIDENHAIN cable; ≤ 8 MHz

⁴⁾ For mechanical fault exclusion, see page 21

¹⁾ For dimensions and specifications, see separate Product Information document

³⁾ See *General electrical information* in the catalog *Interfaces of HEIDENHAIN Encoders*

RON 786/RON 886/RPN 886

- Integrated stator coupling
- Hollow through shaft $\varnothing 60$ mm
- System accuracy $\pm 1''$ or $\pm 2''$

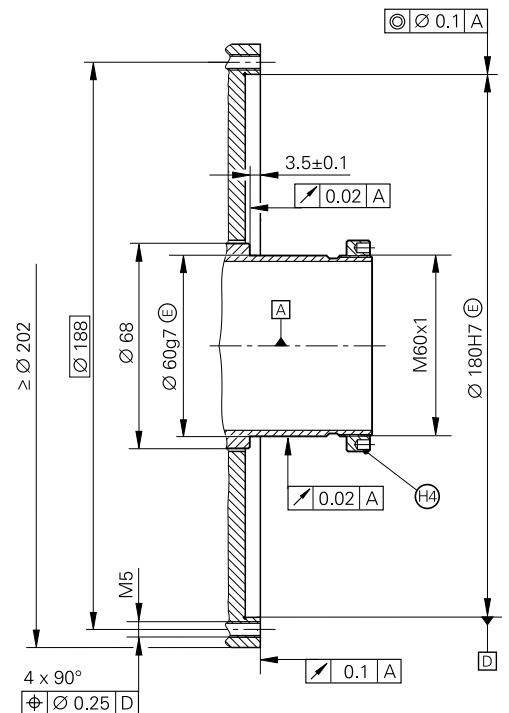
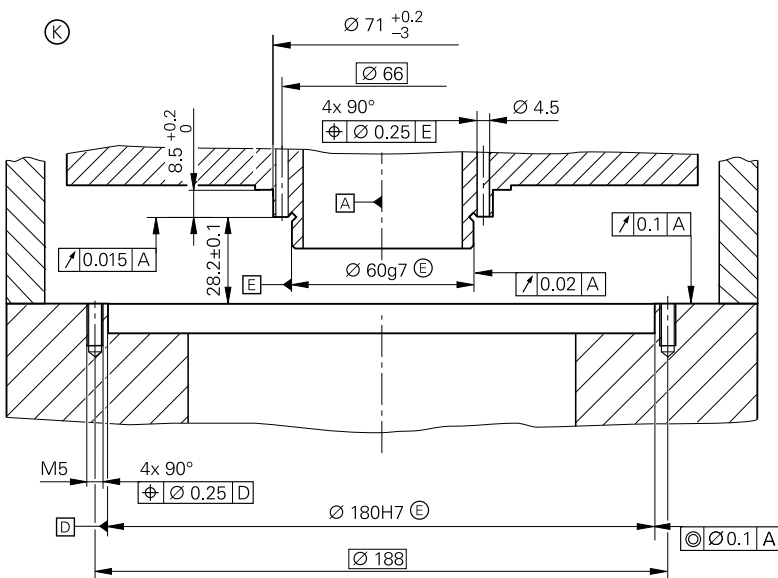
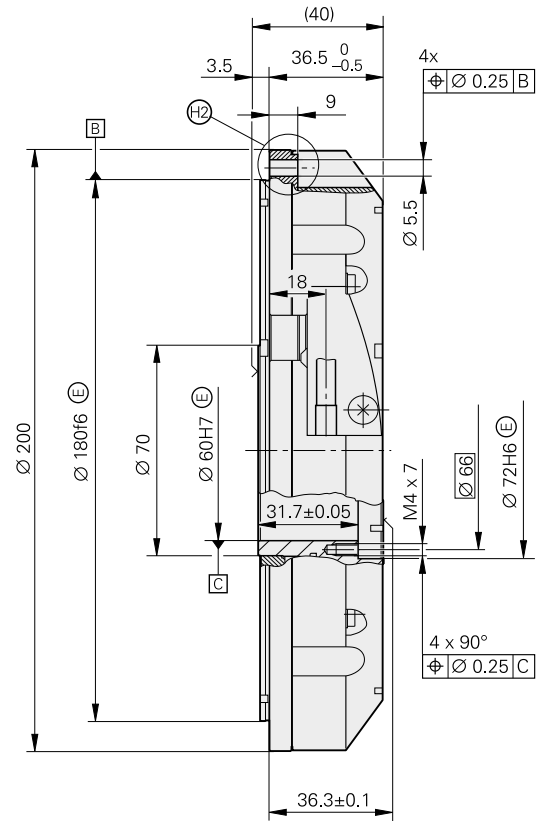
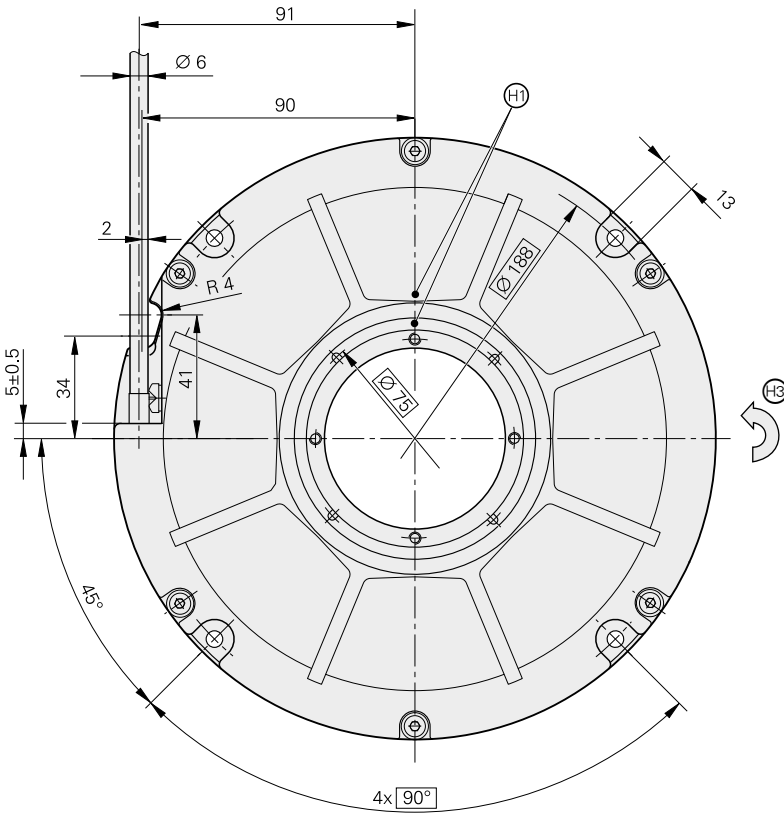

mm



Tolerancing ISO 8015
ISO 2768 - m H
< 6 mm: ± 0.2 mm

Cable radial, also usable axially

▢ = Bearing of mating shaft

⊙ = Required mating dimensions

⊕ = Position of the reference mark signal $\pm 5^\circ$

⊗ = Shown rotated by 45°

⊙ = Direction of shaft rotation for output signals according to interface description

⊕ = Accessory: Ring nut ID 336669-11

| | Incremental RON 786 | RON 886 | RPN 886 |
|---|---|-------------------|--|
| Measuring standard | DIADUR circular scale with incremental track | | |
| Line count* | 18 000 36 000 | 36 000 | 90 000 (\cong 180 000 signal periods) |
| System accuracy | $\pm 2''$ | $\pm 1''$ | |
| Position error per signal period | <i>18 000 lines:</i> $\leq \pm 0.7''$ <i>36 000 lines:</i> $\leq \pm 0.35''$ | $\leq \pm 0.35''$ | $\leq \pm 0.1''$ |
| Interface | $\sim 1 V_{PP}$ | | |
| Reference mark* | <i>RON x86:</i> One <i>RON x86 C:</i> Distance-coded | | One |
| Cutoff frequency | -3 dB -6 dB | ≥ 180 kHz | ≥ 800 kHz ≥ 1300 kHz |
| Electrical connection* | Cable 1 m, with or without M23 coupling (male, 12-pin) | | |
| Cable length ¹⁾ | ≤ 150 m | | |
| Voltage supply | 5 V DC ± 0.5 V/ ≤ 150 mA (without load) | | 5 V DC ± 0.5 V/ ≤ 250 mA (without load) |
| Shaft | Hollow through shaft D = 60 mm | | |
| Mech. permissible speed | ≤ 1000 min ⁻¹ | | |
| Starting torque | ≤ 0.5 Nm at 20 °C | | |
| Moment of inertia of rotor | $1.20 \cdot 10^{-3}$ kgm ² | | |
| Permissible axial motion of measured shaft | $\leq \pm 0.1$ mm | | |
| Natural frequency | ≥ 1000 Hz | | ≥ 500 Hz |
| Vibration 55 to 2000 Hz Shock 6 ms | ≤ 100 m/s ² (EN 60 068-2-6) ≤ 200 m/s ² (EN 60 068-2-27) | | ≤ 50 m/s ² (EN 60 068-2-6) ≤ 200 m/s ² (EN 60 068-2-27) |
| Operating temperature | 0 °C to 50 °C | | |
| Protection EN 60 529 | IP 64 | | |
| Weight | ≈ 2.5 kg | | |

* Please select when ordering

¹⁾ With HEIDENHAIN cable

RON 905

- Integrated stator coupling
- Blind hollow shaft
- System accuracy $\pm 0.4''$

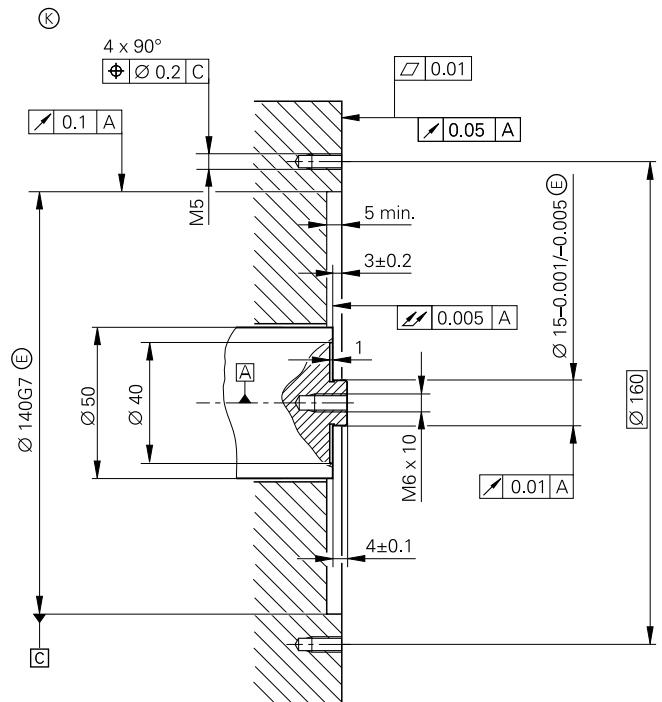
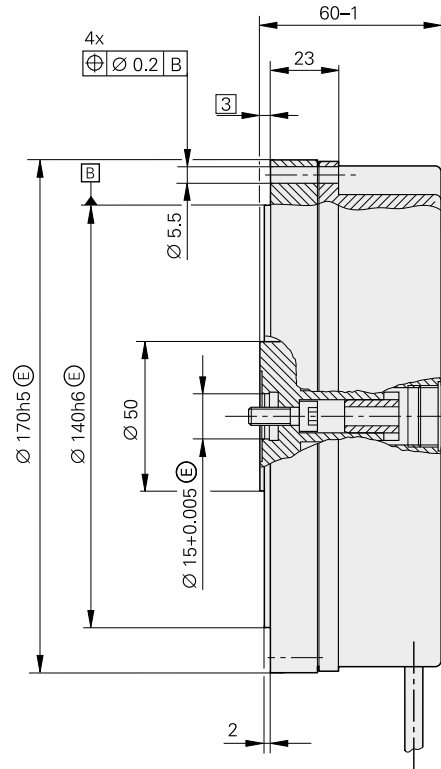
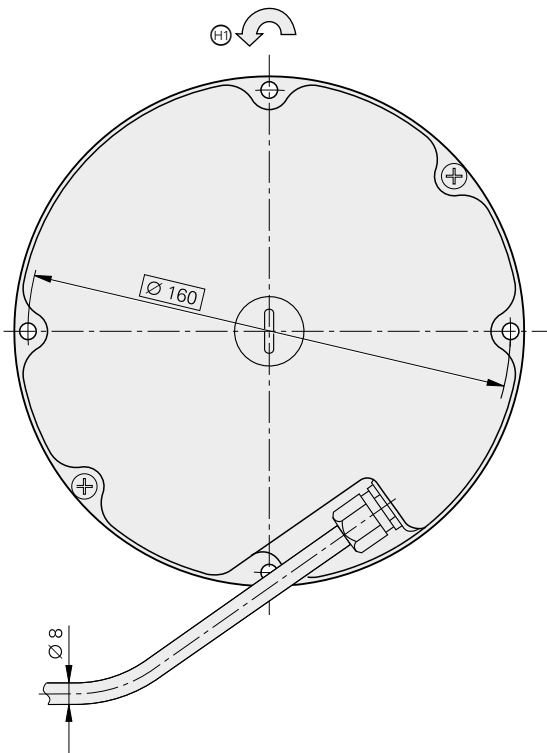

mm
 Tolerancing ISO 8015
 ISO 2768 - m H
 < 6 mm: ± 0.2 mm

Cable radial, also usable axially
 A = Bearing
 K = Required mating dimensions
 R = Direction of shaft rotation for output signal I₂ lagging I₁

| | Incremental RON 905 |
|---|--|
| Measuring standard | DIADUR circular scale with incremental track |
| Line count | 36 000 |
| System accuracy | $\pm 0.4''$ |
| Position error per signal period | $\leq \pm 0.3''$ |
| Interface | $\sim 11 \mu A_{PP}$ |
| Reference mark | One |
| Cutoff frequency -3 dB | $\geq 40 \text{ kHz}$ |
| Electrical connection | Cable 1 m, with M23 connector (male, 9 pin) |
| Voltage supply | 5 V DC $\pm 0.25 \text{ V}/\leq 250 \text{ mA}$ (without load) |
| Cable length ¹⁾ | $\leq 15 \text{ m}$ |
| Shaft | Blind hollow shaft |
| Mech. permissible speed | $\leq 100 \text{ min}^{-1}$ |
| Starting torque | $\leq 0.05 \text{ Nm}$ at 20 °C |
| Moment of inertia of rotor | $0.345 \cdot 10^{-3} \text{ kgm}^2$ |
| Permissible axial motion of measured shaft | $\leq \pm 0.2 \text{ mm}$ |
| Natural frequency | $\geq 350 \text{ Hz}$ |
| Vibration 55 to 2000 Hz Shock 6 ms | $\leq 50 \text{ m/s}^2$ (EN 60 068-2-6) $\leq 200 \text{ m/s}^2$ (EN 60 068-2-27) |
| Operating temperature | 10 °C to 30 °C |
| Protection EN 60 529 | IP 64 |
| Weight | $\approx 4 \text{ kg}$ |

¹⁾ With HEIDENHAIN cable

ECN 200 series

- Mounted stator coupling
- Hollow through shaft with $\varnothing 20$ mm and $\varnothing 50$ mm
- System accuracy $\pm 10''$

ECN 200 $\varnothing 20$ mm



ECN 200 $\varnothing 50$ mm

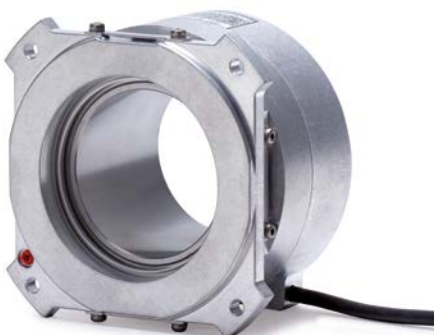

| |
|--|
| Measuring standard |
| System accuracy |
| Position error per signal period |
| Interface |
| Ordering designation* |
| Position values/revolution |
| Electrically permissible speed |
| Clock frequency |
| Calculation time t_{cal} |
| Incremental signals |
| Cutoff frequency -3 dB |
| Electrical connection* |
| Cable length ¹⁾ |
| Voltage supply |
| Power consumption ²⁾ (maximum) |
| Current consumption (typical) |
| Shaft* |
| Mechanically permissible speed |
| Starting torque (at 20 °C) |
| Moment of inertia of rotor |
| Permissible axial motion of measured shaft |
| Natural frequency |
| Vibration 55 to 2000 Hz |
| Shock 6 ms |
| Operating temperature |
| Protection EN 60 529 |
| Weight |

* Please select when ordering

¹⁾ With HEIDENHAIN cable

²⁾ See *General electrical information*

| Absolute ECN 225 | | ECN 223F | ECN 223M |
|--|--|---|------------------------------------|
| DIADUR circular scale with absolute and incremental track (2048 lines) | | | |
| ± 10" | | | |
| ≤ ± 5" | | | |
| EnDat 2.2 | | Fanuc serial interface α Interface | Mitsubishi high speed interface |
| EnDat22 | EnDat02 | Fanuc02 | Mit02-4 |
| 33554432 (25 bits) | | 8388608 (23 bits) | |
| ≤ 3000 min ⁻¹ for continuous position value | | | |
| ≤ 8 MHz | ≤ 2 MHz | – | |
| ≤ 5 μs | | – | |
| – | ~ 1 V _{PP} | – | |
| – | ≥ 200 kHz | – | |
| Cable 1 m, with M12 coupling (male), 8-pin | Cable 1 m, with M23 coupling (male), 17-pin | Cable 1 m, with or without M12 coupling (male, 8-pin) | |
| ≤ 150 m | | ≤ 30 m | |
| 3.6 to 5.25 V DC | | | |
| 3.6 V: ≤ 0.7 W 5.25 V: ≤ 1.0 W | | | |
| 5 V: 200 mA (without load) | | | |
| Hollow-through shaft D = 20 mm or 50 mm | | | |
| ≤ 3000 min ⁻¹ | | | |
| <i>D = 20 mm</i> : ≤ 0.15 Nm <i>D = 50 mm</i> : ≤ 0.2 Nm | | | |
| <i>D = 20 mm</i> : 0.138 · 10 ⁻³ kgm ² <i>D = 50 mm</i> : 0.215 · 10 ⁻³ kgm ² | | | |
| ± 0.1 mm | | | |
| ≥ 1000 Hz | | | |
| ≤ 100 m/s ² (EN 60068-2-6) ≤ 200 m/s ² (EN 60068-2-27) | | | |
| <i>Moving cable</i> : –10 °C to 70 °C <i>Stationary cable</i> : –20 °C to 70 °C | | | |
| IP 64 | | | |
| <i>D = 20 mm</i> : ≈ 0.8 kg; <i>D = 50 mm</i> : ≈ 0.7 kg | | | |

Hollow shaft D = 20 mm

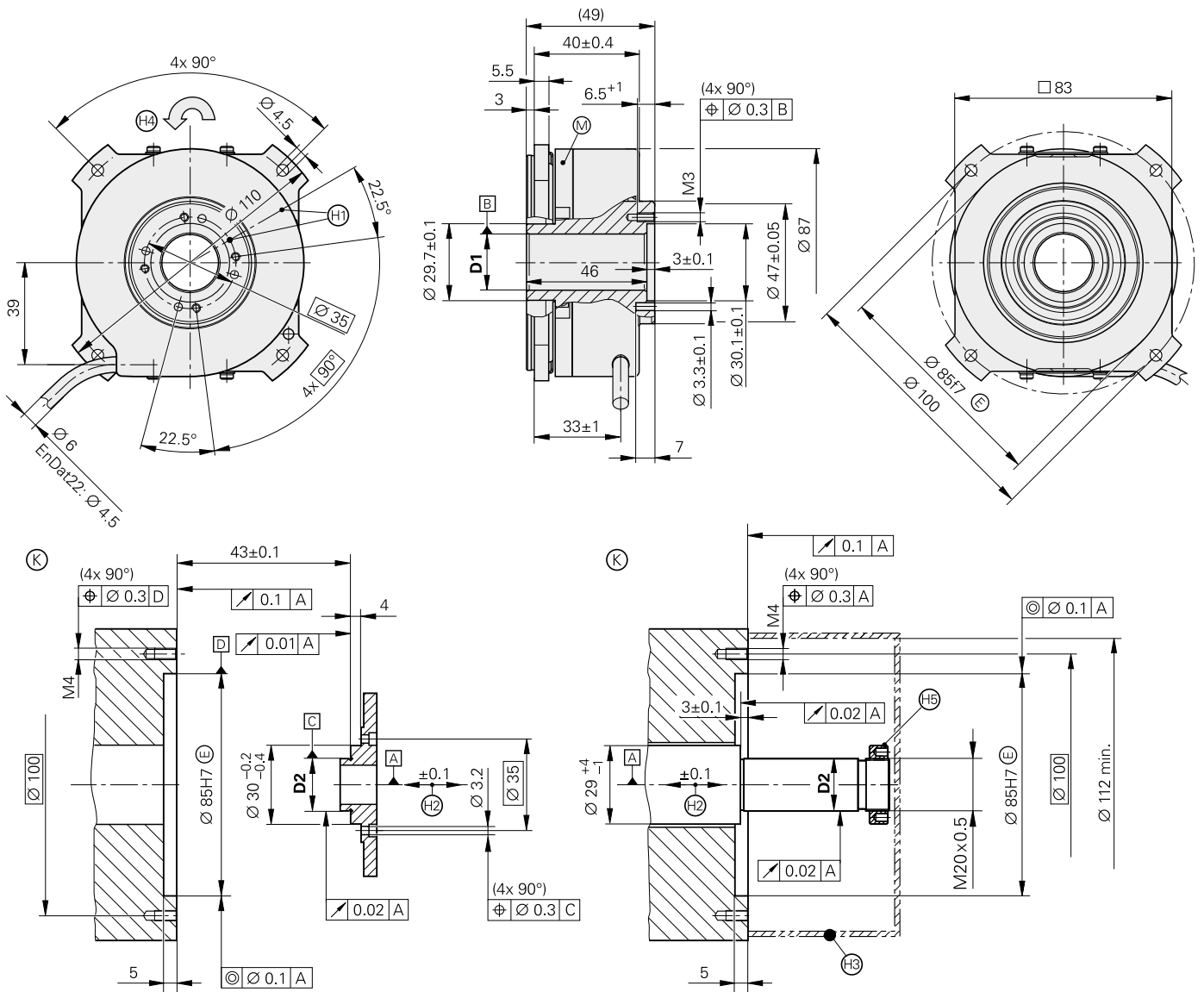



mm

 Tolerancing ISO 8015
 ISO 2768 - m H
 < 6 mm: ± 0.2 mm

| D1 | D2 |
|------------------------|------------------------|
| $\varnothing 20H7 (E)$ | $\varnothing 20g7 (E)$ |

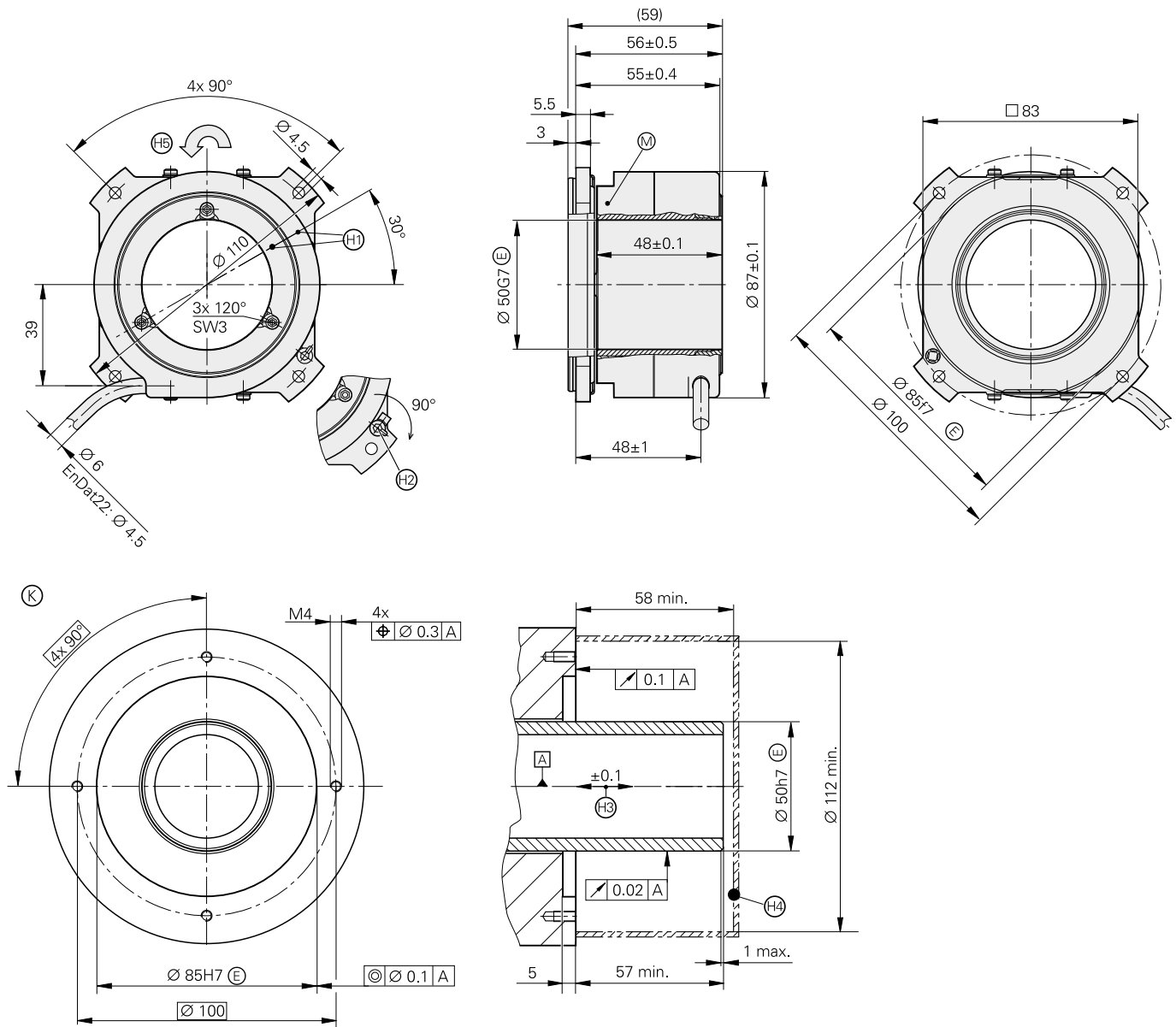
- \square = Bearing of mating shaft
- \square = Bearing of encoder
- \odot = Required mating dimensions
- \oplus = Measuring point for operating temperature
- \oplus = Zero position $\pm 15^\circ$
- \oplus = Maximum permissible motion of motor shaft
- \oplus = Protection against contact as per EN 60529
- \oplus = Direction of shaft rotation for output signals as per the interface description
- \oplus = Accessory: Ring nut ID 336669-03

Hollow shaft D = 50 mm



mm

 Tolerancing ISO 8015
 ISO 2768 - m H
 < 6 mm: ±0.2 mm

- ▣ = Bearing of mating shaft
- ⊗ = Required mating dimensions
- Ⓜ = Measuring point for operating temperature
- Ⓟ = Zero position ± 15°
- Ⓠ = Remove mounting aid before putting into operation. Width A/F 3
- Ⓡ = Maximum permissible motion of motor shaft
- Ⓢ = Protection against contact as per EN 60529
- Ⓣ = Direction of shaft rotation for output signals as per the interface description

ROD 200 series

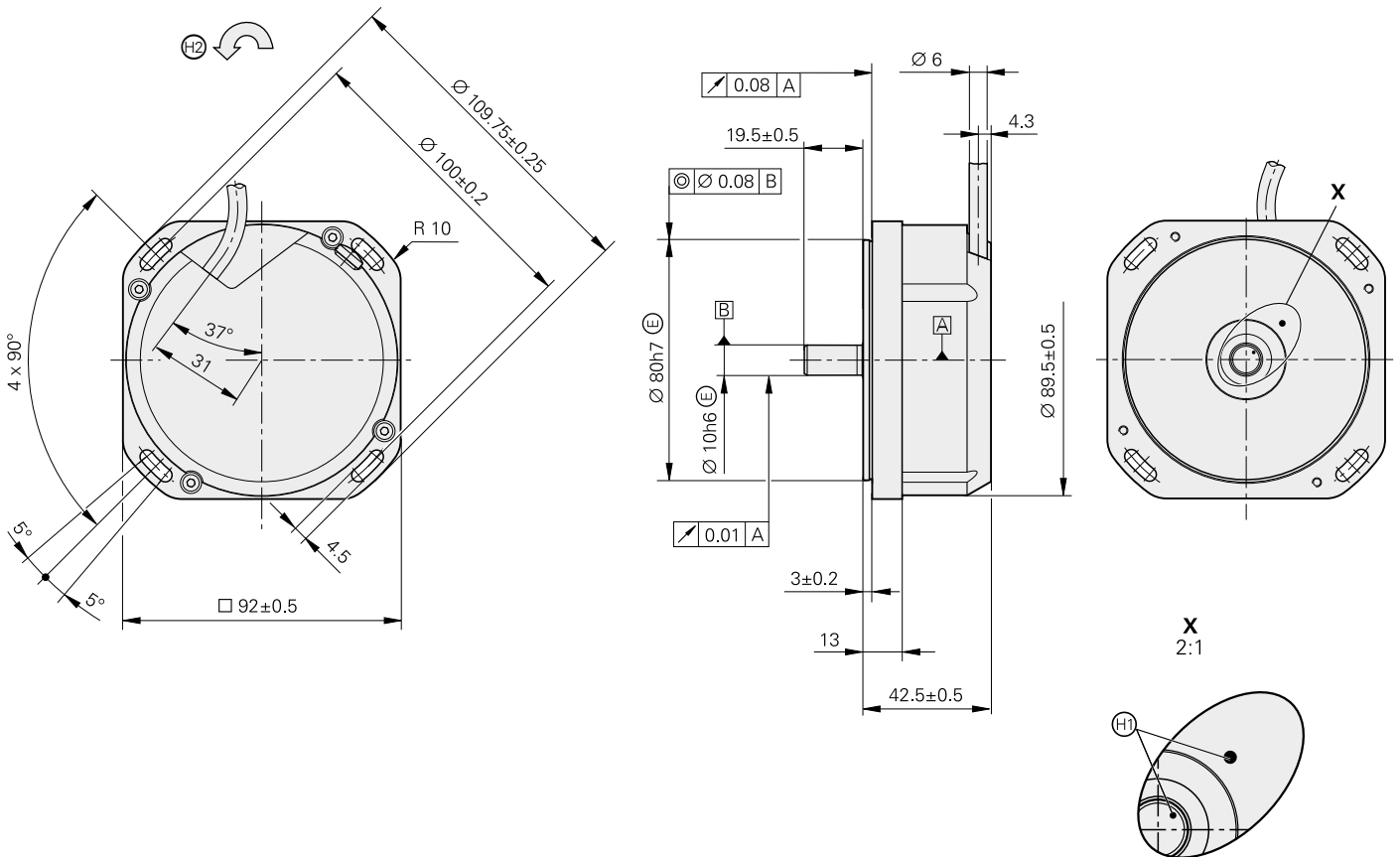
- For separate shaft coupling
- System accuracy $\pm 5''$



mm

 Tolerancing ISO 8015
 ISO 2768 - m H
 < 6 mm: ± 0.2 mm

Cable radial, also usable axially
 ▴ = Bearing
 H2 = Position of the reference mark signal $\pm 5''$
 H1 = Direction of shaft rotation for output signals as per the interface description

| | Incremental ROD 220 | ROD 270 | ROD 280 |
|---|---|---------------------------|--|
| Measuring standard | DIADUR circular scale with incremental track | | |
| Line count | 9000 | 18000 | 18000 |
| System accuracy | ± 5" | | |
| Position error per signal period | ≤ ± 1.4" | ≤ ± 0.7" | |
| Interface | □□TTL | | ~ 1 V _{PP} |
| Integrated interpolation Output signals/rev | 2-fold 18000 | 10-fold 180000 | – 18000 |
| Reference mark* | One | | <i>ROD 280: One ROD 280C: Distance-coded</i> |
| Cutoff frequency –3 dB Output frequency Edge separation a | – ≤ 1 MHz ≥ 0.125 μs | – ≤ 1 MHz ≥ 0.22 μs | ≥ 180 kHz – – |
| Electrically permissible speed | ≤ 3333 min ⁻¹ | ≤ 333 min ⁻¹ | – |
| Electrical connection* | Cable 1 m, with or without M23 coupling (male, 12-pin) | | |
| Cable length ¹⁾ | ≤ 100 m | | ≤ 150 m |
| Voltage supply | 5 V DC ± 0.5 V/≤ 150 mA (without load) | | |
| Shaft | Solid shaft D = 10 mm | | |
| Mech. permissible speed | ≤ 10000 min ⁻¹ | | |
| Starting torque | ≤ 0.01 Nm at 20 °C | | |
| Moment of inertia of rotor | 20 · 10 ⁻⁶ kgm ² | | |
| Shaft load | <i>Axial: 10 N Radial: 10 N at shaft end</i> | | |
| Vibration 55 to 2000 Hz Shock 6 ms | ≤ 100 m/s ² (EN 60068-2-6) ≤ 200 m/s ² (EN 60068-2-27) | | |
| Operating temperature | <i>Moving cable: –10 °C to 70 °C Stationary cable: –20 °C to 70 °C</i> | | |
| Protection EN 60 529 | IP 64 | | |
| Weight | ≈ 0.7 kg | | |

* Please select when ordering

¹⁾ With HEIDENHAIN cable

ROD 780/ROD 880

- For separate shaft coupling
- System accuracy $\pm 1''$ or $\pm 2''$

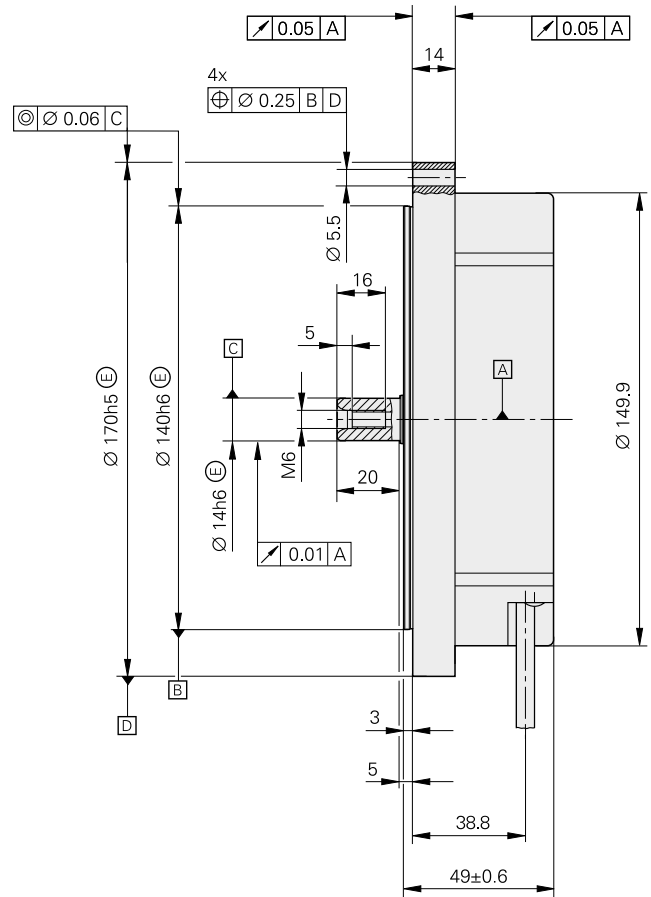
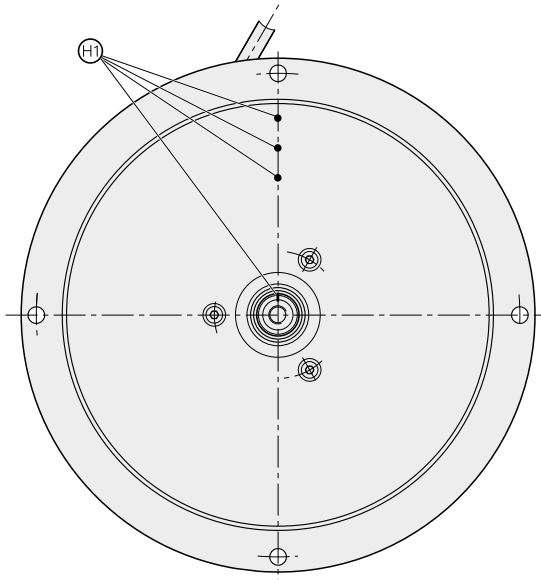
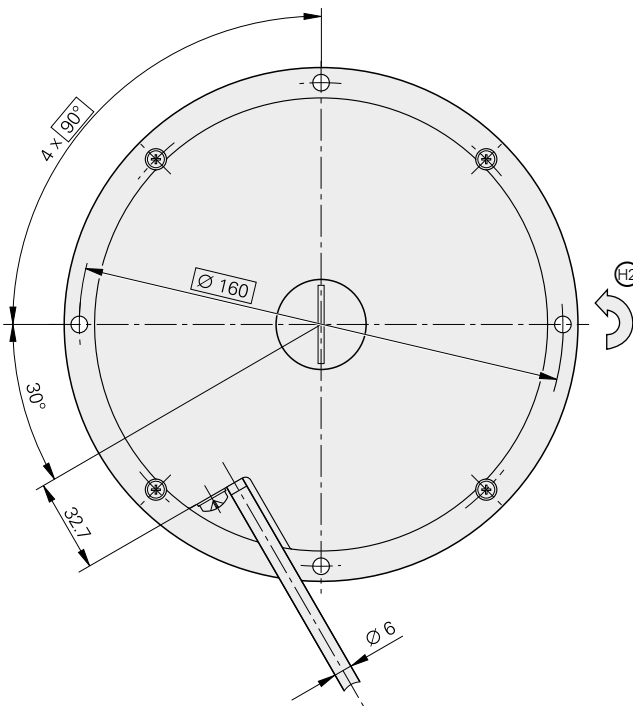

mm
 Tolerancing ISO 8015
 ISO 2768 - m H
 < 6 mm: ± 0.2 mm

Cable radial, also usable axially
 A = Bearing
 H = Position of the reference mark signal $\pm 5^\circ$
 H = Direction of shaft rotation for output signals as per the interface description

| | Incremental ROD 780 | ROD 880 |
|---|---|----------------|
| Measuring standard | DIADUR circular scale with incremental track | |
| Line count* | 18 000 36 000 | 36 000 |
| System accuracy | ± 2" | ± 1" |
| Position error per signal period | <i>18 000 lines</i> : ≤ ± 0.7" <i>36 000 lines</i> : ≤ ± 0.35" | ≤ ± 0.35" |
| Interface | ~ 1 V _{PP} | |
| Reference mark* | <i>ROD x80</i> : One <i>ROD x80C</i> : Distance-coded | |
| Cutoff frequency -3 dB | ≥ 180 kHz | |
| Electrical connection* | Cable 1 m, with or without M23 coupling (male, 12-pin) | |
| Cable length ¹⁾ | ≤ 150 m | |
| Voltage supply | 5 V DC ± 0.5 V/≤ 150 mA (without load) | |
| Shaft | Solid shaft D = 14 mm | |
| Mech. permissible speed | ≤ 1000 min ⁻¹ | |
| Starting torque | ≤ 0.012 Nm at 20 °C | |
| Moment of inertia of rotor | 0.36 · 10 ⁻³ kgm ² | |
| Shaft load | <i>Axial</i> : 30 N <i>Radial</i> : 30 N at shaft end | |
| Vibration 55 to 2000 Hz Shock 6 ms | ≤ 100 m/s ² (EN 60068-2-6) ≤ 200 m/s ² (EN 60068-2-27) | |
| Operating temperature | 0 °C to 50 °C | |
| Protection EN 60 529 | IP 64 | |
| Weight | ≈ 2.4 kg | |

* Please select when ordering

¹⁾ With HEIDENHAIN cable

Interfaces

Incremental signals $\sim 1 V_{PP}$

HEIDENHAIN encoders with $\sim 1 V_{PP}$ interface provide voltage signals that can be highly interpolated.

The sinusoidal **incremental signals** A and B are phase-shifted by 90° elec. and have amplitudes of typically $1 V_{PP}$. The illustrated sequence of output signals—with B lagging A—applies for the direction of motion shown in the dimension drawing.

The **reference mark signal** R has an unambiguous assignment to the incremental signals. The output signal might be somewhat lower next to the reference mark.

Comprehensive descriptions of all available interfaces as well as general electrical information are included in the *Interfaces for HEIDENHAIN Encoders* catalog.

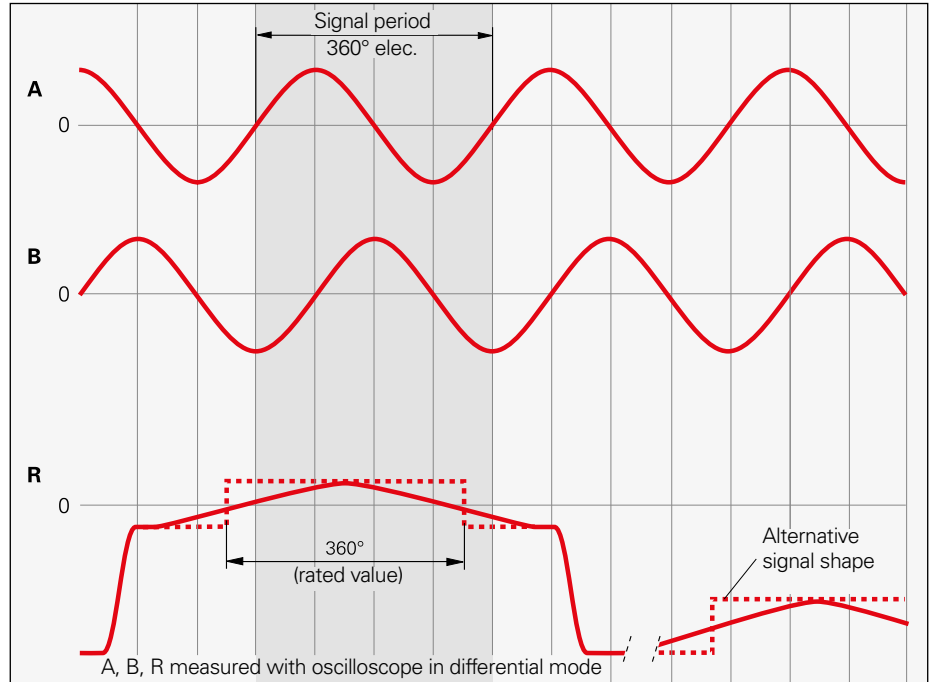

Pin layout

| 12-pin coupling, M23 | | | | | 12-pin connector, M23 | | | | | | | | | | |
|------------------------------------|-----------------|-------------------------------|-----------------|----------------------------|------------------------|-------|------|------|-----|-------|---------------|--------|--------|--|--|
| | | | | | | | | | | | | | | | |
| 15-pin D-sub connector | | | | | 15-pin D-sub connector | | | | | | | | | | |
| For HEIDENHAIN controls and IK 220 | | | | | For encoder or PWM 20 | | | | | | | | | | |
| | | | | | | | | | | | | | | | |
| | Power supply | | | | Incremental signals | | | | | | Other signals | | | | |
| | 12 | 2 | 10 | 11 | 5 | 6 | 8 | 1 | 3 | 4 | 9 | 7 | / | | |
| | 1 | 9 | 2 | 11 | 3 | 4 | 6 | 7 | 10 | 12 | 5/8/13/15 | 14 | / | | |
| | 4 | 12 | 2 | 10 | 1 | 9 | 3 | 11 | 14 | 7 | 5/6/8/15 | 13 | / | | |
| | U_P | Sensor ¹⁾ U_P | 0V | Sensor ¹⁾ 0V | A+ | A- | B+ | B- | R+ | R- | Vacant | Vacant | Vacant | | |
| | Brown/ Green | Blue | White/ Green | White | Brown | Green | Gray | Pink | Red | Black | / | Violet | Yellow | | |

Cable shield connected to housing; U_P = Power supply voltage

Sensor: The sensor line is connected in the encoder with the corresponding power line.

Vacant pins or wires must not be used!

¹⁾ LIDA 2xx: Vacant

Incremental signals \square TTL

HEIDENHAIN encoders with \square TTL interface incorporate electronics that digitize sinusoidal scanning signals with or without interpolation.

The **incremental signals** are transmitted as the square-wave pulse trains U_{a1} and U_{a2} , phase-shifted by 90° elec. The **reference mark signal** consists of one or more reference pulses U_{a0} , which are gated with the incremental signals. In addition, the integrated electronics produce their **inverted signals** $\overline{U_{a1}}$, $\overline{U_{a2}}$ and $\overline{U_{a0}}$ for noise-proof transmission. The illustrated sequence of output signals—with U_{a2} lagging U_{a1} —applies to the direction of motion shown in the dimension drawing.

The **fault detection signal** $\overline{U_{aS}}$ indicates fault conditions such as an interruption in the supply lines, failure of the light source, etc.

The distance between two successive edges of the incremental signals U_{a1} and U_{a2} through 1-fold, 2-fold or 4-fold evaluation is one **measuring step**.

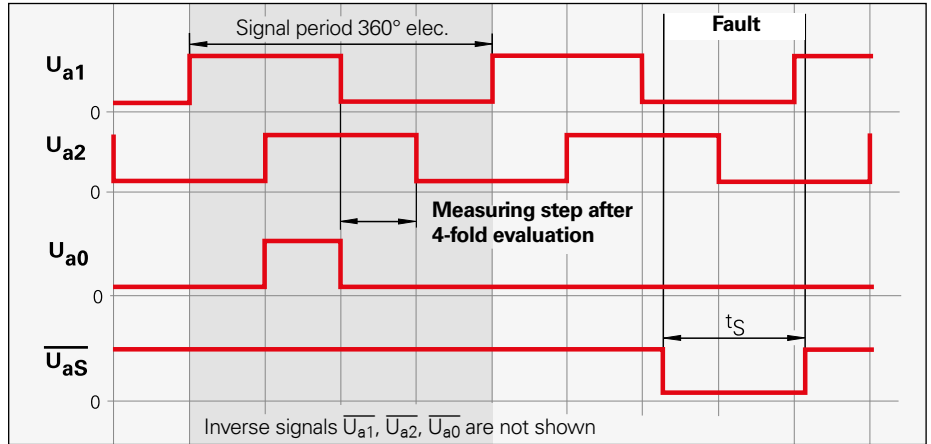

Comprehensive descriptions of all available interfaces as well as general electrical information are included in the *Interfaces for HEIDENHAIN Encoders* catalog.

Pin layout

| 12-pin coupling, M23 | | | | 12-pin connector, M23 | | | | | | | | | |
|--|-----------------|-------------------------------|-----------------|---|----------|---------------------|----------|---------------------|----------|---------------------|-----------------------------------|---------|------------------|
| | | | | | | | | | | | | | |
| 15-pin D-sub connector For HEIDENHAIN controls and IK 220 | | | | 15-pin D-sub connector For encoder or PWM 20 | | | | | | | | | |
| | | | | | | | | | | | | | |
| | Power supply | | | Incremental signals | | | | | | Other signals | | | |
| | 12 | 2 | 10 | 11 | 5 | 6 | 8 | 1 | 3 | 4 | 7 | / | 9 ³⁾ |
| | 1 | 9 | 2 | 11 | 3 | 4 | 6 | 7 | 10 | 12 | 14 | 8/13/15 | 5 |
| | 4 | 12 | 2 | 10 | 1 | 9 | 3 | 11 | 14 | 7 | 13 | 5/6/8 | 15 ³⁾ |
| | U_P | Sensor ¹⁾ U_P | 0V | Sensor ¹⁾ 0V | U_{a1} | $\overline{U_{a1}}$ | U_{a2} | $\overline{U_{a2}}$ | U_{a0} | $\overline{U_{a0}}$ | $\overline{U_{aS}}$ ²⁾ | Vacant | Vacant |
| | Brown/ Green | Blue | White/ Green | White | Brown | Green | Gray | Pink | Red | Black | Violet | / | Yellow |

Cable shield connected to housing; U_P = Power supply voltage

Sensor: The sensor line is connected in the encoder with the corresponding power line.

Vacant pins or wires must not be used!

¹⁾ LIDA 2xx: Vacant / ²⁾ ERO 14xx: Vacant

³⁾ **Exposed linear encoders:** Switchover TTL/11 μA_{PP} for PWT, otherwise vacant

Interfaces

Position values

The EnDat interface is a digital, **bidirectional** interface for encoders. It is capable both of transmitting **position values** as well as transmitting or updating information stored in the encoder, or saving new information. Thanks to the **serial transmission method**, only **four signal lines** are required. The DATA data is transmitted in **synchronism** with the CLOCK signal from the subsequent electronics. The type of transmission (position values, parameters, diagnostics, etc.) is selected through mode commands that the subsequent electronics send to the encoder. Some functions are available only with EnDat 2.2 mode commands.





Comprehensive descriptions of all available interfaces as well as general electrical information are included in the *Interfaces for HEIDENHAIN Encoders* catalog.

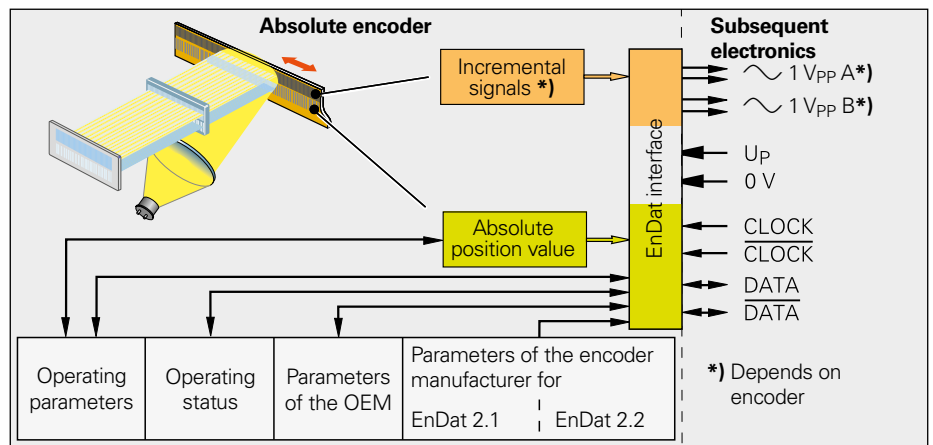



| Ordering designation | Command set | Incremental signals |
|----------------------|------------------------|---------------------|
| EnDat01 | EnDat 2.1 or EnDat 2.2 | With |
| EnDat21 | | Without |
| EnDat02 | EnDat 2.2 | With |
| EnDat22 | EnDat 2.2 | Without |

Versions of the EnDat interface



Pin layout

| 8-pin coupling, M12 | | | | | | | | |
|---|----------------|-----------|-------------|-----------|--------------------------|------|--------|--------|
|  | Voltage supply | | | | Absolute position values | | | |
|  | 8 | 2 | 5 | 1 | 3 | 4 | 7 | 6 |
|  | Up | Sensor Up | 0V | Sensor 0V | DATA | DATA | CLOCK | CLOCK |
|  | Brown/Green | Blue | White/Green | White | Gray | Pink | Violet | Yellow |

| 17-pin coupling, M23 | | | | | | 15-pin D-sub connector For HEIDENHAIN controls and IK 220 | | | | | | | |
|---|--------------|-----------|-------------|-----------|-----------------|--|--------------|------------|-----------|--------------------------|------|--------|--------|
|  | Power supply | | | | | Incremental signals ¹⁾ | | | | Absolute position values | | | |
|  | 7 | 1 | 10 | 4 | 11 | 15 | 16 | 12 | 13 | 14 | 17 | 8 | 9 |
|  | 1 | 9 | 2 | 11 | 13 | 3 | 4 | 6 | 7 | 5 | 8 | 14 | 15 |
|  | Up | Sensor Up | 0V | Sensor 0V | Internal shield | A+ | A- | B+ | B- | DATA | DATA | CLOCK | CLOCK |
|  | Brown/Green | Blue | White/Green | White | / | Green/Black | Yellow/Black | Blue/Black | Red/Black | Gray | Pink | Violet | Yellow |

Cable shield connected to housing; **Up** = Power supply voltage

Sensor: The sensor line is connected in the encoder with the corresponding power line.

Vacant pins or wires must not be used!

¹⁾ Only with order designations EnDat01 and EnDat02

Interfaces







Fanuc and Mitsubishi pin layouts

Fanuc

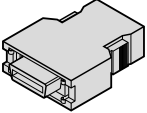
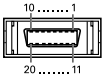
HEIDENHAIN encoders with the code letter F after the model designation are suited for connection to Fanuc controls with

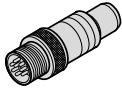
- **Fanuc Serial Interface – α Interface**
Ordering designation: Fanuc02
Normal and high speed, two-pair transmission

- **Fanuc Serial Interface – α interface**
Ordering designation: Fanuc05
High speed, one-pair transmission
Includes α interface (normal and high speed, two-pair transmission)

| 20-pin Fanuc connector | | | | | 8-pin M12 coupling | | | | |
|---|---|---|-----------------|---------------------|---|---|---|----------------|----------------|
|  |  |  | | |  |  |  | | |
| | Voltage supply | | | | | Absolute position values | | | |
|  | 9 | 18/20 | 12 | 14 | 16 | 1 | 2 | 5 | 6 |
|  | 8 | 2 | 5 | 1 | – | 3 | 4 | 7 | 6 |
| | U_P | Sensor U _P | 0V | Sensor 0V | Shield | Serial Data | Serial Data | Request | Request |
|  | Brown/ Green | Blue | White/ Green | White | – | Gray | Pink | Violet | Yellow |

Cable shield connected to housing; **U_P** = Power supply voltage

Sensor: The sensor line is connected in the encoder with the corresponding power line.
Vacant pins or wires must not be used!









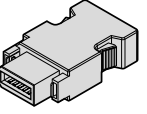
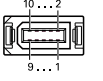

Mitsubishi

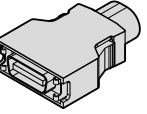
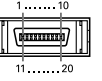
HEIDENHAIN encoders with the code letter M after the model designation are suited for connection to Mitsubishi controls with

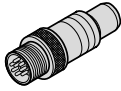
Mitsubishi high speed interface

- Ordering designation: Mitsu01
Two-pair transmission

- Ordering designation: Mit02-4
Generation 1, two-pair transmission
- Ordering designation: Mit02-2
Generation 1, one-pair transmission
- Ordering designation: Mit03-4
Generation 2, two-pair transmission

| 10-pin Mitsubishi connector | | | 20-pin Mitsubishi connector | | | | 8-pin M12 coupling | | |
|---|---|---|---|---|--|---|---|---|----------------------|
|  |  |  |  |  |  |  |  |  | |
| | Voltage supply | | | | | Absolute position values | | | |
|  | 10-pin | 1 | – | 2 | – | 7 | 8 | 3 | 4 |
|  | 20-pin | 20 | 19 | 1 | 11 | 6 | 16 | 7 | 17 |
|  | | 8 | 2 | 5 | 1 | 3 | 4 | 7 | 6 |
| | | U_P | Sensor U _P | 0V | Sensor 0V | Serial Data | Serial Data | Request Frame | Request Frame |
|  | | Brown/Green | Blue | White/Green | White | Gray | Pink | Violet | Yellow |

Cable shield connected to housing; **U_P** = Power supply voltage

Sensor: The sensor line is connected in the encoder with the corresponding power line.
Vacant pins or wires must not be used!

Connecting elements and cables

General information

Connector (insulated): Connecting element with coupling ring; available with male or female contacts (see symbols).

Symbols

M12

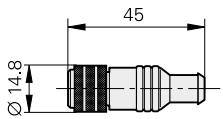

M12 right-angle connector

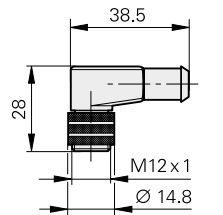

M23

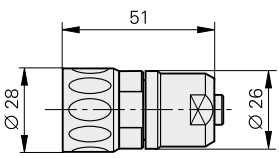

Coupling (insulated): Connecting element with external thread; available with male or female contacts (see symbols).

Symbols

On the adapter cable

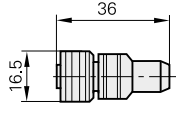

M12

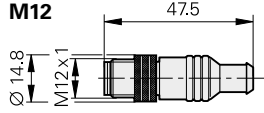

M23

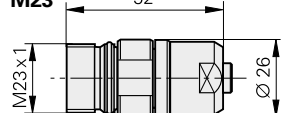

Mounted coupling with central fastening

Cutout for mounting

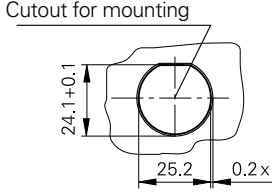

M23

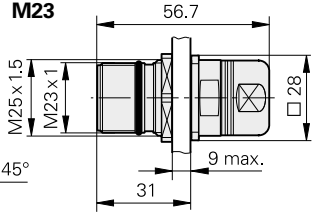

Mounted coupling with flange

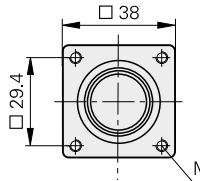

M23

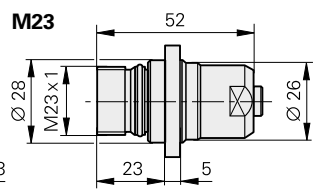

D-sub connector for HEIDENHAIN controls, counters and IK absolute value cards.

Symbols

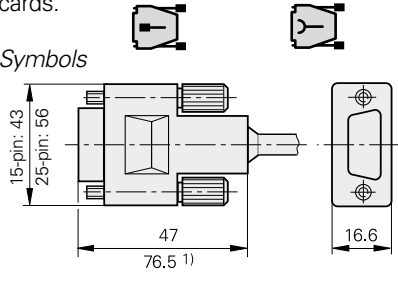

¹⁾ With integrated interface electronics

Flange socket with external thread; permanently mounted on a housing, available with male or female contacts.

Symbols

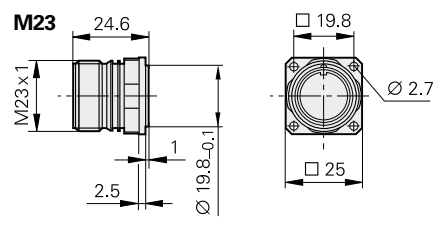

The pins on connectors are **numbered** in the direction opposite to those on couplings or flange sockets, regardless of whether the connecting elements have

male contacts or



female contacts.



Accessories for flange sockets and M23 mounted couplings

Threaded metal dust cap
ID 219926-01

Accessory for M12 connecting element
Insulation spacer
ID 596495-01

When engaged, the connections are **protected** to IP 67 (D-sub connector: IP 50; EN 60 529). When not engaged, there is no protection.

Connecting elements $\sim 1 V_{PP}$

TTL

EnDat

12-pin





17-pin

8-pin

M23

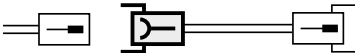
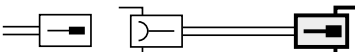
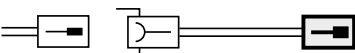
M23

M12

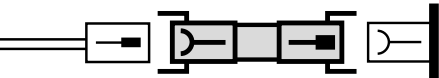



| | | | | |
|--|---|-------------------------------------|-------------------------------------|-------------|
| Mating element on connecting cable to connector on encoder cable | Connector (female) for cable \varnothing 8 mm  | 291697-05 | 291697-26 | - |
| Connector on connecting cable for connection to subsequent electronics | Connector (male) for cable \varnothing 4.5 mm \varnothing 8 mm \varnothing 6 mm  | 291697-06 291697-08 291697-07 | - 291697-27 - | - - - |
| Coupling on connecting cable | Coupling (male) for cable \varnothing 4.5 mm \varnothing 6 mm \varnothing 8 mm  | 291698-14 291698-03 291698-04 | 291698-25 291698-26 291698-27 | - - - |
| Flange socket for mounting on subsequent electronics | Flange socket (female)  | 315892-08 | 315892-10 | - |
| Mounted couplings | With flange (female) \varnothing 6 mm \varnothing 8 mm  | 291698-17 291698-07 | 291698-35 - | - - |
| | With flange (male) \varnothing 6 mm \varnothing 8 mm  | 291698-08 291698-31 | 291698-41 291698-29 | - - |
| | With central fastener (male) \varnothing 6 mm to 10 mm  | 741045-01 | 741045-02 | - |
| Adapter $\sim 1 V_{PP}/11 \mu A_{PP}$ For converting the $1 V_{PP}$ signals to $11 \mu A_{PP}$; M23 connector (female, 12-pin) and M23 connector (male, 9-pin) |  | 364914-01 | - | - |



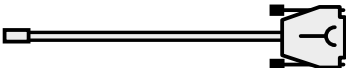
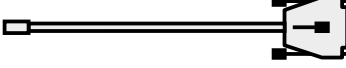

Connecting cables $\sim 1 V_{PP}$

 TTL
EnDat

12-pin M23 17-pin M23 8-pin M12

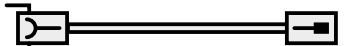
| | | |
|--|--------------------------------|-----------------------------------|
| $\sim 1 V_{PP}$  TTL | EnDat with incremental signals | EnDat without incremental signals |
|--|--------------------------------|-----------------------------------|

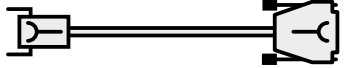
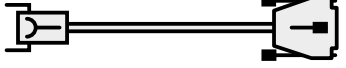
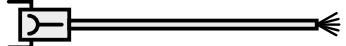

| PUR adapter cable | 8-pin: 17-pin: | $\varnothing 4.5 \text{ mm}; [4 \times 2 \times 0.14 \text{ mm}^2]$ $\varnothing 6 \text{ mm}; [6 \times 2 \times 0.19 \text{ mm}^2]$ | $A_P = 0.14 \text{ mm}^2$ $A_P = 0.19 \text{ mm}^2$ | | |
|---|---|--|--|----------------|-----------|
| Complete with • M12 coupling (male), 8-pin • M23 coupling (male), 17-pin |  | – | – | 679671-xx – | – |
| Complete with M23 coupling (male), 17-pin with central fastening (M23 SpeedTEC) |  | – | – | 1072523-xx | – |
| Complete with D-sub connector (female), 15-pin |  | – | – | 727658-xx | 735987-xx |
| Complete with D-sub connector (female), 25-pin | | – | – | 735961-xx | 735994-xx |
| Complete with D-sub connector (male), 15-pin |  | – | – | – | 735993-xx |
| With one connector |  | – | – | 681186-xx | 680856-xx |



| PUR connecting cable | 8-pin: 17-pin: 12-pin: | $\varnothing 6 \text{ mm}; [4 \times 0.14 \text{ mm}^2 + 4 \times 0.34 \text{ mm}^2]$ $\varnothing 8 \text{ mm}; [4 \times 2 \times 0.14 \text{ mm}^2 + 4 \times 0.5 \text{ mm}^2 + 4 \times 0.14 \text{ mm}^2]$ $\varnothing 8 \text{ mm}; [4 \times 2 \times 0.14 \text{ mm}^2 + 4 \times 0.5 \text{ mm}^2]$ | $A_P = 0.34 \text{ mm}^2$ $A_P = 0.5 \text{ mm}^2$ $A_P = 0.5 \text{ mm}^2$ | | |
|---|---|--|---|-----------|---|
| Complete with connector (female) and coupling (male) |  | 298401-xx | 323897-xx | 368330-xx | – |
| Complete with connectors (female and male) |  | 298399-xx | – | – | – |
| Complete with connector (female) and D-sub connector (female), 15-pin |  | 310199-xx | 332115-xx | 533627-xx | – |
| Complete with connector (female) and D-sub connector (female), 25-pin | | – | 509667-xx | 641926-xx | – |
| Complete with connector (female) and D-sub connector (male), 15-pin |  | 310196-xx | 324544-xx | 524599-xx | – |
| With one connector (female) |  | 309777-xx | 309778-xx | 634265-xx | – |
| Cable only |  | 816317-xx | 816322-xx | 816329-xx | – |

A_P : Cross section of power supply lines

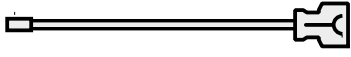
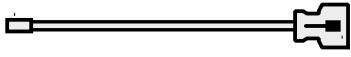
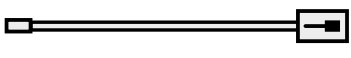
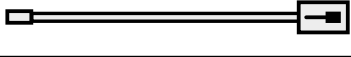
\varnothing : Cable diameter (for bend radii, see catalog *Interfaces of HEIDENHAIN Encoders*)

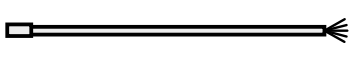
Connecting cables Fanuc Mitsubishi

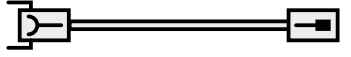
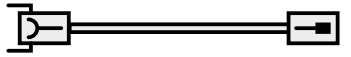
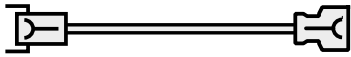
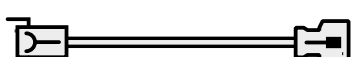
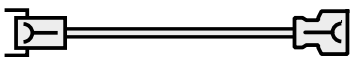
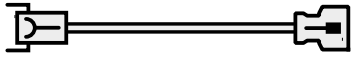
| PUR adapter cable | $\varnothing 4.5 \text{ mm}; [4 \times 2 \times 0.14 \text{ mm}^2]$ $A_p = 0.14 \text{ mm}^2$ | Fanuc | Mitsubishi |
|--|---|--------------|-------------------|
| Complete with • Fanuc connector (female) or • Mitsubishi connector (female), 10-pin |  | 770967-xx | 770968-xx |
| Complete with Mitsubishi connector (male), 20-pin |  | – | 770966-xx |
| Complete with M12 coupling (male), 8-pin |  | 679671-xx | |
| Complete with M23 coupling (male), 17-pin |  | 827607-xx | |
| Complete with M23 coupling (male), 17-pin with central fastening (M23 SpeedTEC) |  | 1034884-xx | |
| With one connector |  | 680856-xx | |

| PUR connecting cable | ① $\varnothing 6 \text{ mm}; [4 \times 0.14 \text{ mm}^2 + 4 \times 0.34 \text{ mm}^2]$ $A_p = 0.34 \text{ mm}^2$ ② $\varnothing 8 \text{ mm}; [2 \times 2 \times 0.14 \text{ mm}^2 + 4 \times 1 \text{ mm}^2]$ $A_p = 1 \text{ mm}^2$ ③ $\varnothing 6 \text{ mm}; [2 \times 2 \times 0.14 \text{ mm}^2 + 4 \times 0.5 \text{ mm}^2]$ $A_p = 0.5 \text{ mm}^2$ | Cable | Fanuc | Mitsubishi |
|---|---|--------------|--------------|-------------------|
| Complete with M12 connector (female), 8-pin, and M12 coupling (male), 8-pin |  | ① | 368330-xx | |
| Complete with M12 connector (female), 8-pin and M23 coupling (male), 17-pin |  | ① | 582333-xx | |
| Complete with M12 connector (female), 8-pin, and • Fanuc connector (female) or • Mitsubishi connector (female), 10-pin |  | ① | 646807-xx | 647314-xx |
| Complete with M12 connector (female), 8-pin, and Mitsubishi connector (male), 20-pin |  | ① | – | 646806-xx |
| Complete with M23 connector (female), 17-pin, and • Fanuc connector (female) or • Mitsubishi connector (female), 10-pin |  | ② | 534855-xx | 573661-xx |
| Complete with M23 connector (female), 17-pin, and Mitsubishi connector (male), 20-pin |  | ③ | – | 367958-xx |
| Cable only |  | ② | 816327-xx | |

A_p : Cross section of power supply lines

\varnothing : Cable diameter (for bend radii, see catalog *Interfaces of HEIDENHAIN Encoders*)

Diagnostic and testing equipment

HEIDENHAIN encoders are provided with all information necessary for commissioning, monitoring and diagnostics. The type of available information depends on whether the encoder is incremental or absolute and which interface is used.

Incremental encoders mainly have 1 V_{PP}, TTL or HTL interfaces. TTL and HTL encoders monitor their signal amplitudes internally and generate a simple fault detection signal. With 1 V_{PP} signals, the analysis of output signals is possible only in external test devices or through computation in the subsequent electronics (**analog diagnostics interface**).

Absolute encoders operate with serial data transfer. Depending on the interface, additional 1 V_{PP} incremental signals can be output. The signals are monitored comprehensively within the encoder. The monitoring result (especially with valuation numbers) can be transferred along with the position value through the serial interface to the subsequent electronics (**digital diagnostics interface**). The following information is available:

- Error message: Position value not reliable
- Warning: An internal functional limit of the encoder has been reached
- Valuation numbers:
 - Detailed information on the encoder's functional reserve
 - Identical scaling for all HEIDENHAIN encoders
 - Cyclic output is possible

This enables the subsequent electronics to evaluate the current status of the encoder at little cost even in closed-loop mode.

HEIDENHAIN offers the appropriate PWM inspection devices and PWT test devices for encoder analysis. There are two types of diagnostics, depending on how they are integrated:

- Encoder diagnostics: The encoder is connected directly to the test or inspection device. This makes a comprehensive analysis of encoder functions possible.
- Diagnostics in the control loop: The PWM phase meter is looped into the closed control loop (e.g. through a suitable testing adapter). This makes a real-time diagnosis of the machine or system possible during operation. The functions depend on the interface.

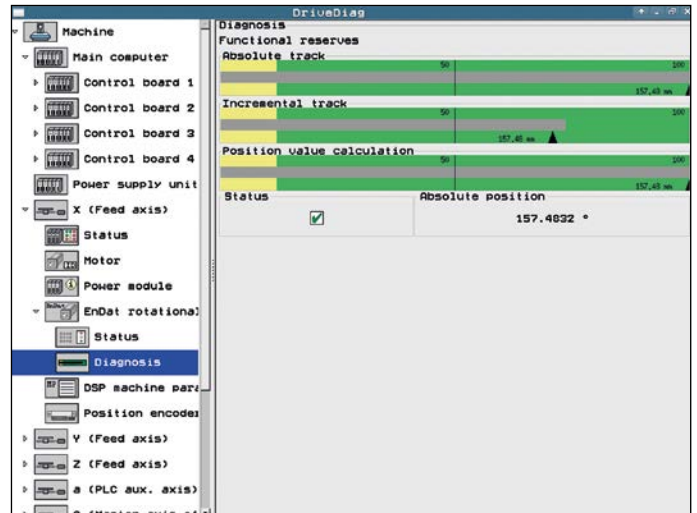

Diagnostics in the control loop on HEIDENHAIN controls with display of the valuation number or the analog encoder signals

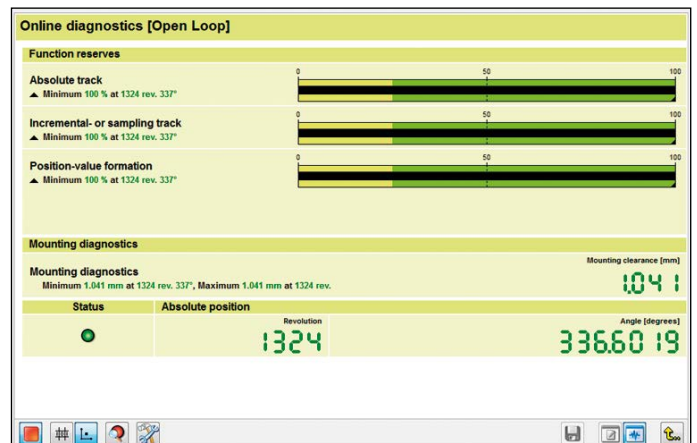

Diagnostics using PWM 20 and ATS software



Commissioning using PWM 20 and ATS software

PWM 20

Together with the ATS adjusting and testing software, the PWM 20 phase angle measuring unit serves for diagnosis and adjustment of HEIDENHAIN encoders.



For more information, refer to the Product Information document *PWM 20/ATS Software*.

| | PWM 20 |
|-----------------------|---|
| Encoder input | <ul style="list-style-type: none"> • EnDat 2.1 or EnDat 2.2 (absolute value with/without incremental signals) • DRIVE-CLiQ • Fanuc Serial Interface • Mitsubishi high speed interface • Yaskawa Serial Interface • Panasonic serial interface • SSI • 1 V_{PP}/TTL/11 μA_{PP} • HTL (via signal adapter) |
| Interface | USB 2.0 |
| Voltage supply | 100 V to 240 V AC or 24 V DC |
| Dimensions | 258 mm x 154 mm x 55 mm |

| | ATS |
|--|--|
| Languages | Choice between English and German |
| Functions | <ul style="list-style-type: none"> • Position display • Connection dialog • Diagnostics • Mounting wizard for EBI/ECI/EQI, LIP 200, LIC 4000 and others • Additional functions (if supported by the encoder) • Memory contents |
| System requirements and recommendations | PC (dual-core processor, > 2 GHz) RAM > 2 GB Windows operating systems XP, Vista, 7 (32-bit/64-bit), 8 200 MB free space on hard disk |

DRIVE-CLiQ is a registered trademark of Siemens Aktiengesellschaft

The **PWM 9** is a universal measuring device for checking and adjusting HEIDENHAIN incremental encoders. Expansion modules are available for checking the various types of encoder signals. The values can be read on an LCD monitor. Soft keys provide ease of operation.



| | PWM 9 |
|-----------------------|--|
| Inputs | Expansion modules (interface boards) for 11 μA _{PP} ; 1 V _{PP} ; TTL; HTL; EnDat*/SSI*/commutation signals *No display of position values or parameters |
| Functions | <ul style="list-style-type: none"> • Measures signal amplitudes, current consumption, operating voltage, scanning frequency • Graphically displays incremental signals (amplitudes, phase angle and on-off ratio) and the reference-mark signal (width and position) • Displays symbols for the reference mark, fault-detection signal, counting direction • Universal counter, interpolation selectable from single to 1024-fold • Adjustment support for exposed linear encoders |
| Outputs | <ul style="list-style-type: none"> • Inputs are connected through to the subsequent electronics • BNC sockets for connection to an oscilloscope |
| Voltage supply | 10 V to 30 V DC, max. 15 W |
| Dimensions | 150 mm x 205 mm x 96 mm |

Interface electronics

Interface electronics from HEIDENHAIN adapt the encoder signals to the interface of the subsequent electronics. They are used when the subsequent electronics cannot directly process the output signals from HEIDENHAIN encoders, or if additional interpolation of the signals is necessary.

Input signals of the interface electronics

Interface electronics from HEIDENHAIN can be connected to encoders with sinusoidal signals of 1 V_{PP} (voltage signals) or 11 μA_{PP} (current signals). Encoders with the serial interfaces EnDat or SSI can also be connected to various interface electronics.

Output signals of the interface electronics

Interface electronics with the following interfaces to the subsequent electronics are available:

- TTL square-wave pulse trains
- EnDat 2.2
- DRIVE-CLiQ
- Fanuc Serial Interface
- Mitsubishi high speed interface
- Yaskawa Serial Interface
- Profibus

Interpolation of the sinusoidal input signals

In addition to being converted, the sinusoidal encoder signals are also interpolated in the interface electronics. This permits finer measuring steps and, as a result, higher control quality and better positioning behavior.

Formation of a position value

Some interface electronics have an integrated counting function. Starting from the last reference point set, an absolute position value is formed when the reference mark is traversed, and is transferred to the subsequent electronics.

Box design



Plug design



Version for integration



Top-hat rail design



| Outputs | | Inputs | | Design – Protection class | Interpolation ¹⁾ or subdivision | Model | | |
|---|-----------------|-------------------------|----------------|---------------------------------|--|-------------------------|-------------------|-----------------|
| Interface | Qty. | Interface | Qty. | | | | | |
| □ TTL | 1 | ~ 1 V _{PP} | 1 | Box design – IP 65 | 5/10-fold | IBV 101 | | |
| | | | | | 20/25/50/100-fold | IBV 102 | | |
| | | | | | Without interpolation | IBV 600 | | |
| | | | | | 25/50/100/200/400-fold | IBV 660B | | |
| | | | | Plug design – IP 40 | 5/10/20/25/50/100-fold | APE 371 | | |
| | | | | Version for integration – IP 00 | 5/10-fold | IDP 181 | | |
| | | 20/25/50/100-fold | IDP 182 | | | | | |
| | | ~ 11 μA _{PP} | 1 | | | Box design – IP 65 | 5/10-fold | EXE 101 |
| | | | | | | | 20/25/50/100-fold | EXE 102 |
| | | | | | | | Without/5-fold | EXE 602E |
| 25/50/100/200/400-fold | EXE 660B | | | | | | | |
| Version for integration – IP 00 | | | | | 5-fold | IDP 101 | | |
| | | | | | | | | |
| □ TTL/ ~ 1 V _{PP} Adjustable | 2 | ~ 1 V _{PP} | 1 | Box design – IP 65 | 2-fold | IBV 6072 | | |
| | | | | | 5/10-fold | IBV 6172 | | |
| | | | | | 5/10-fold and 20/25/50/100-fold | IBV 6272 | | |
| EnDat 2.2 | 1 | ~ 1 V _{PP} | 1 | Box design – IP 65 | ≤ 16384-fold subdivision | EIB 192 | | |
| | | | | Plug design – IP 40 | ≤ 16384-fold subdivision | EIB 392 | | |
| | | | 2 | Box design – IP 65 | ≤ 16384-fold subdivision | EIB 1512 | | |
| DRIVE-CLiQ | 1 | EnDat 2.2 | 1 | Box design – IP 65 | – | EIB 2391S | | |
| Fanuc serial interface | 1 | ~ 1 V _{PP} | 1 | Box design – IP 65 | ≤ 16384-fold subdivision | EIB 192F | | |
| | | | | Plug design – IP 40 | ≤ 16384-fold subdivision | EIB 392F | | |
| | | | 2 | Box design – IP 65 | ≤ 16384-fold subdivision | EIB 1592F | | |
| Mitsubishi high speed interface | 1 | ~ 1 V _{PP} | 1 | Box design – IP 65 | ≤ 16384-fold subdivision | EIB 192M | | |
| | | | | Plug design – IP 40 | ≤ 16384-fold subdivision | EIB 392M | | |
| | | | 2 | Box design – IP 65 | ≤ 16384-fold subdivision | EIB 1592M | | |
| Yaskawa serial interface | 1 | EnDat 2.2 ²⁾ | 1 | Plug design – IP 40 | – | EIB 3391Y | | |
| PROFIBUS-DP | 1 | EnDat 2.1; EnDat 2.2 | 1 | Top-hat rail design | – | PROFIBUS Gateway | | |

¹⁾ Switchable

²⁾ Only LIC 4100 with 5 nm measuring step, LIC 2100 with 50 nm and 100 nm measuring steps

HEIDENHAIN

DR. JOHANNES HEIDENHAIN GmbH

Dr.-Johannes-Heidenhain-Straße 5

83301 Traunreut, Germany

☎ +49 8669 31-0

FAX +49 8669 32-5061

E-mail: info@heidenhain.de

www.heidenhain.de

Vollständige und weitere Adressen siehe www.heidenhain.de
For complete and further addresses see www.heidenhain.de

| | | | | | |
|-----------|--|-----------|--|-----------|---|
| DE | HEIDENHAIN Vertrieb Deutschland 83301 Traunreut, Deutschland ☎ 08669 31-3132 FAX 08669 32-3132 E-Mail: hd@heidenhain.de | ES | FARRESA ELECTRONICA S.A. 08028 Barcelona, Spain www.farresa.es | PL | APS 02-384 Warszawa, Poland www.heidenhain.pl |
| | HEIDENHAIN Technisches Büro Nord 12681 Berlin, Deutschland ☎ 030 54705-240 | FI | HEIDENHAIN Scandinavia AB 02770 Espoo, Finland www.heidenhain.fi | PT | FARRESA ELECTRÓNICA, LDA. 4470 - 177 Maia, Portugal www.farresa.pt |
| | HEIDENHAIN Technisches Büro Mitte 07751 Jena, Deutschland ☎ 03641 4728-250 | FR | HEIDENHAIN FRANCE sarl 92310 Sèvres, France www.heidenhain.fr | RO | HEIDENHAIN Reprezentantă Romania Braşov, 500407, Romania www.heidenhain.ro |
| | HEIDENHAIN Technisches Büro West 44379 Dortmund, Deutschland ☎ 0231 618083-0 | GB | HEIDENHAIN (G.B.) Limited Burgess Hill RH15 9RD, United Kingdom www.heidenhain.co.uk | RS | Serbia → BG |
| | HEIDENHAIN Technisches Büro Südwest 70771 Leinfelden-Echterdingen, Deutschland ☎ 0711 993395-0 | GR | MB Milionis Vassilis 17341 Athens, Greece www.heidenhain.gr | RU | OOO HEIDENHAIN 115172 Moscow, Russia www.heidenhain.ru |
| | HEIDENHAIN Technisches Büro Südost 83301 Traunreut, Deutschland ☎ 08669 31-1345 | HK | HEIDENHAIN LTD Kowloon, Hong Kong E-mail: sales@heidenhain.com.hk | SE | HEIDENHAIN Scandinavia AB 12739 Skärholmen, Sweden www.heidenhain.se |
| AR | NAKASE SRL. B1653AOX Villa Ballester, Argentina www.heidenhain.com.ar | HR | Croatia → SL | SG | HEIDENHAIN PACIFIC PTE LTD. Singapore 408593 www.heidenhain.com.sg |
| AT | HEIDENHAIN Techn. Büro Österreich 83301 Traunreut, Germany www.heidenhain.de | HU | HEIDENHAIN Kereskedelmi Képviselet 1239 Budapest, Hungary www.heidenhain.hu | SK | KOPRETINA TN s.r.o. 91101 Trencin, Slovakia www.kopretina.sk |
| AU | FCR Motion Technology Pty. Ltd Laverton North 3026, Australia E-mail: vicsales@fcrmotion.com | ID | PT Servitama Era Toolsindo Jakarta 13930, Indonesia E-mail: ptset@group.gts.co.id | SL | NAVO d.o.o. 2000 Maribor, Slovenia www.heidenhain.si |
| BE | HEIDENHAIN NV/SA 1760 Roosdaal, Belgium www.heidenhain.be | IL | NEUMO VARGUS MARKETING LTD. Tel Aviv 61570, Israel E-mail: neumo@neumo-vargus.co.il | TH | HEIDENHAIN (THAILAND) LTD Bangkok 10250, Thailand www.heidenhain.co.th |
| BG | ESD Bulgaria Ltd. Sofia 1172, Bulgaria www.esd.bg | IN | HEIDENHAIN Optics & Electronics India Private Limited Chetpet, Chennai 600 031, India www.heidenhain.in | TR | T&M Mühendislik San. ve Tic. LTD. ŞTİ. 34775 Y. Dudullu – Ümraniye-Istanbul, Turkey www.heidenhain.com.tr |
| BR | DIADUR Indústria e Comércio Ltda. 04763-070 – São Paulo – SP, Brazil www.heidenhain.com.br | IT | HEIDENHAIN ITALIANA S.r.l. 20128 Milano, Italy www.heidenhain.it | TW | HEIDENHAIN Co., Ltd. Taichung 40768, Taiwan R.O.C. www.heidenhain.com.tw |
| BY | GERTNER Service GmbH 220026 Minsk, Belarus www.heidenhain.by | JP | HEIDENHAIN K.K. Tokyo 102-0083, Japan www.heidenhain.co.jp | UA | Gertner Service GmbH Büro Kiev 01133 Kiev, Ukraine www.heidenhain.ua |
| CA | HEIDENHAIN CORPORATION Mississauga, Ontario L5T2N2, Canada www.heidenhain.com | KR | HEIDENHAIN Korea LTD. Gasan-Dong, Seoul, Korea 153-782 www.heidenhain.co.kr | US | HEIDENHAIN CORPORATION Schaumburg, IL 60173-5337, USA www.heidenhain.com |
| CH | HEIDENHAIN (SCHWEIZ) AG 8603 Schwerzenbach, Switzerland www.heidenhain.ch | MX | HEIDENHAIN CORPORATION MEXICO 20290 Aguascalientes, AGS., Mexico E-mail: info@heidenhain.com | VE | Maquinaria Diekmann S.A. Caracas, 1040-A, Venezuela E-mail: purchase@diekmann.com.ve |
| CN | DR. JOHANNES HEIDENHAIN (CHINA) Co., Ltd. Beijing 101312, China www.heidenhain.com.cn | MY | ISOSERVE SDN. BHD. 43200 Balakong, Selangor E-mail: isoserve@po.jaring.my | VN | AMS Co. Ltd HCM City, Vietnam E-mail: davidgoh@amsvn.com |
| CZ | HEIDENHAIN s.r.o. 102 00 Praha 10, Czech Republic www.heidenhain.cz | NL | HEIDENHAIN NEDERLAND B.V. 6716 BM Ede, Netherlands www.heidenhain.nl | ZA | MAFEMA SALES SERVICES C.C. Midrand 1685, South Africa www.heidenhain.co.za |
| DK | TPTEKNIKA/S 2670 Greve, Denmark www.tp-gruppen.dk | NO | HEIDENHAIN Scandinavia AB 7300 Orkanger, Norway www.heidenhain.no | | |
| | | PH | Machinebanks Corporation Quezon City, Philippines 1113 E-mail: info@machinebanks.com | | |

